

# Electronics

M c G R A W - H I L L P U B L I C A T I O N

APRIL · 1950

THIS ISSUE MARKS  
*20 Years*  
OF SERVICE

A woman with dark, curly hair, wearing a light blue short-sleeved blouse and a dark vest, is operating a large industrial machine. She is using a tool to adjust a large, cylindrical component on the machine. The machine is dark-colored with various rollers and belts. In the background, there are other industrial components and a control panel with several knobs and switches. The overall scene is a factory or workshop environment.

CAPACITOR WINDER  
MOTOR CONTROL





# COMMERCIAL GRADE COMPONENTS

A wide range of units for every application

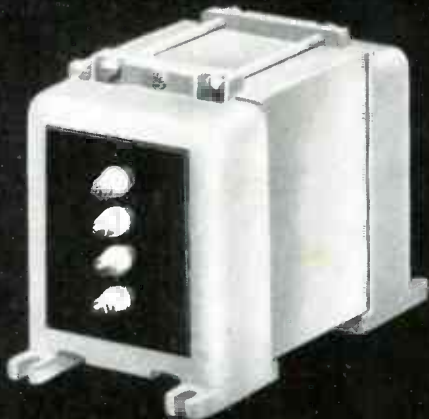

U.T.C. Commercial Grade components employ rugged, drawn steel construction for units from 1" diameter to 30" diameter. VA rating . . . vertical mounting, permanent mold, aluminum castings for power components up to 15 KVA. Units are conservatively designed . . . vacuum impregnated . . . sealed with special sealing compound to insure dependability under continuous commercial service.

A few of the large number of standard C.G. units are described below. In addition to catalogued units, special C.G. units are supplied to customer's specifications.

## CG VARIMATCH OUTPUTS FOR P. A.

Universal units designed to match any tubes within the rated output power, to line or voice coil. Output impedance 500, 200, 50, 16, 8, 5, 3, 1.5 ohms. Primary impedance 3000, 5000, 6000, 7000, 8000, 10,000, 14,000 ohms.

Type No.	Audio Watts	Typical Tubes	List Price
CVP-1	12	42, 43, 45, 47, 2A3, 6A6, 6F6, 25L6	\$ 9.00
CVP-2	30	42, 45, 2A3, 6L6, 6V6, 6B5	14.00
CVP-3	60	46's, 50's, 300A's, 6L6's, 801, 807	20.00
CVP-4	125	800's, 801's, 807's, 4-6L6's, 845's	29.00
CVP-5	300	211, 242A's, 203A's, 838's, 4-845's, ZB-120's	50.00

## CG VARIMATCH LINE TO VOICE COIL TRANSFORMERS

The UTC VARIMATCH line to voice coil transformers will match any voice coil or group of voice coils to a 500 ohm line. More than 50 voice coil combinations can be obtained, as follows:

.2, .4, .5, .62, 1, 1.25, 1.5, 2, 2.5, 3, 3.3, 3.8, 4, 4.5, 5, 5.5, 6, 6.25, 6.6, 7, 7.5, 8, 9, 10, 11, 12, 14, 15, 16, 18, 20, 25, 28, 30, 31, 40, 47, 50, 63, 59, 75.

Type No.	Audio Watts	Primary Impedance	Secondary Impedance	List Price
CVL-1	15	500 ohms	.2 to 75 ohms	\$ 8.00
CVL-2	40	500 ohms	.2 to 75 ohms	11.50
CVL-3	75	500 ohms	.2 to 75 ohms	17.50

## CG VARIMATCH MODULATION UNITS

Will match any modulator tubes to any RF load.

Primary impedances from 500 to 20,000 ohms  
Secondary impedances from 30,000 to 300 ohms

Type No.	Max. Audio Watts	Max. Class C Input	Typical Modulator Tubes	List Price
CVM-0	12	25	30, 49, 79, 6A6, 53, 2A3, 6B5	\$ 8.50
CVM-1	30	60	6V6, 6B5, 2A3, 42, 46, 6L6, 210	14.00
CVM-2	60	125	801, 6L6, 809, 4-46, T-20, 1608	20.50
CVM-3	125	250	800, 807, 845, TZ-20, RK-30, 35-T	30.00
CVM-4	300	600	50-T, 203A, 805, 838, T-55, ZB-129	50.00
CVM-5	600	1200	805, HF-300, 204A, HK-354, 250TH	115.00

## INPUT, INTERSTAGE, MIXING AND LOW LEVEL OUTPUT TRANSFORMERS

(200 ohm windings are balanced and can be used for 250 ohms)

CG Type No.	Application	Primary Impedance Ohms	Secondary Impedance Ohms	Ratio	List Price
131	1 plate to 1 grid	15,000	135,000	3:1 ratio	\$ 9.50
132	1 plate to 2 grids	15,000	135,000	center-tapped 3:1 ratio overall	10.00
133	2 plates to 2 grids	30,000 P to P	80,000 overall	1.6:1 ratio overall	12.50
134	Line to 1 grid hum-bucking	50, 200, 500	80,000		12.50
135	Line to 2 grids hum-bucking	50, 200, 500	120,000 overall		13.50
235	Line to 1 or 2 grids, hum-bucking; multiple alloy shielded for low hum pickup	50, 200, 500 ohms	80,000 overall		17.50
136	Single plate and low impedance mike or line to 1 or 2 grids Hum-bucking	15,000, 50, 200	80,000 overall		13.50
233	PP 6C5, 56, similar triodes to AB 45's, 2A3's, 6L6's, etc.	30,000 P to P	25,000 overall	.9:1 ratio overall	11.00
333	PP 6C5, 56, similar triodes to fixed bias 6L6's	30,000 P to P	7,500 overall	.3:1 ratio overall	11.00
433	PP 45, 2A3, similar tubes to fixed bias 2 or 4 6L6's	5,000 P to P	1,250 overall	.3:1 ratio overall	12.00
137	Mixing	50, 200, 500	50, 200, 500		10.00
140	Triode plate to line	15,000	50, 200, 500		12.00
141	PP triode plates to line	15,000	50, 200, 500		13.50

*United Transformer Co.*  
150 VARICK STREET NEW YORK 13, N. Y.

EXPORT DIVISION: 13 EAST 40th STREET, NEW YORK 16, N. Y., CABLES: "ARLAB"

For full details on this line, write for Catalog

# electronics

A McGRAW-HILL  
PUBLICATION



APRIL • 1950

<b>CAPACITOR WINDER MOTOR CONTROL</b> .....	Cover
Westinghouse unit equipped with thyratron tubes facilitates handling of delicate foils during production of component parts (See page 118)	
<b>ELECTRON TUBES—1930 to 1950</b> .....	66
The history of electronics revolves around them, and major advances in design are noted	
<b>UHF TELEVISION FIELD TEST</b> , by R. F. Guy .....	70
First experimental station, erected at Bridgeport, Conn., relays New York vhf programs at uhf	
<b>AIRPLANE FUEL GAGE</b> , by Curtiss R. Schafer .....	77
Weight of gasoline is measured by capacitance-type self-balancing bridge	
<b>DEVELOPMENTS IN COMMUNICATION THEORY</b> , by Claude E. Shannon .....	80
Clarifies relationships between information, bandwidth, channel capacity and noise	
<b>PIN-POINTING ULTRASONIC ENERGY</b> , by H. J. Dana and J. L. Van Meter .....	84
A system for recording on non-light-sensitive paper without contact	
<b>TELEVISION PRODUCTION TECHNIQUES</b> , by Ricardo Muniz .....	86
Conveyor accessories, subassembly jigs and assembly-line fixtures insure quality and cut costs	
<b>MEASURING SMOKE DENSITY</b> , by P. S. Dickey .....	93
Sealed-in-glass construction and unique bolometer circuit give high accuracy over long periods	
<b>REDUCING UNWANTED MOBILE RADIATION</b> , by D. Pinkerton and N. Shepherd .....	96
Testing techniques for discovering spurious and harmonic radiations and methods of reducing them	
<b>CITIZENS BAND REGULATIONS</b> , by Leo M. Conner .....	100
An interpretation of FCC rules governing 460 to 470-mc transmitter operation	
<b>OPTAR—A NEW SYSTEM OF OPTICAL RANGING</b> .....	102
Applications include infrared "radar", automatic camera focussing, devices for the blind	
<b>SIMPLIFIED INTERCARRIER SOUND</b> , by Walter J. Stroh .....	106
Application of gated beam tube reduces number of tubes and tuned circuits	
<b>SYNTHETIC CRYSTALS</b> , by Charles E. Green .....	110
Design and performance characteristics are discussed in detail	
<b>EQUALIZER DESIGN CHART (Reference Sheet)</b> , by Charles Boegli .....	114
Attenuation or accentuation of base and treble in audio circuits are quickly determined	
<b>BUSINESS BRIEFS</b> .....	60
<b>CROSSTALK</b> .....	65
<b>TUBES AT WORK</b> .....	116
<b>ELECTRON ART</b> .....	120
<b>NEW PRODUCTS</b> .....	124
<b>NEWS OF THE INDUSTRY</b> .....	128
<b>NEW BOOKS</b> .....	132
<b>BACKTALK</b> .....	132
<b>INDEX TO ADVERTISERS</b> (Facing Back Cover)	

**DONALD G. FINK**, Editor; **W. W. MacDONALD**, Managing Editor; John Markus, Vin Zeluff, A. A. McKenzie, Associate Editors; William P. O'Brien, James D. Fahnestock, Assistant Editors; Ann Mastropolo, Marilyn Wood, Editorial Assistants; Gladys T. Montgomery, Washington Editor; Harry Phillips, Art Director; Eleanor Luke, Art Assistant

**KEITH HENNEY**, Consulting Editor

**H. W. MATEER**, Publisher; **WALLACE B. BLOOD**, Manager; **R. S. Quint**, Directory Manager; **D. H. Miller**, James Girdwood, New York; **Wm. S. Hodgkinson**, New England; **Warren W. Shew**, Philadelphia; **C. D. Wardner**, Chicago; **J. L. Phillips**, Cleveland; **J. W. Otterson**, San Francisco; **Carl W. Dysinger**, Los Angeles; **Ralph C. Maultsby**, Atlanta; **Bernard H. Butler**, London, England

Contents Copyright 1950, by McGraw-Hill Publishing Company, Inc. All Rights Reserved. McGRAW-HILL PUBLISHING COMPANY, INCORPORATED, JAMES H. McGRAW (1860-1948), Founder • PUBLICATION OFFICE, 99-129 North Broadway, Albany 1, N. Y., U. S. A. EDITORIAL AND EXECUTIVE OFFICES, 330 West 42nd St., New York 18, N. Y., U. S. A.—Member A. B. P., Member A. B. C.

Curtis W. McGraw, President; Willard Chevalier, Executive Vice-President; Joseph A. Gerardi, Secretary and Treasurer; Eugene Duffield, Senior Vice-President, Publications Division; Nelson Bond, Vice-President and Director of Advertising; J. E. Blackburn, Jr., Vice-President and Director of Circulation; Dexter Keezer, Director Economics Department; Russell F. Anderson, Editor, World News.  
ELECTRONICS: April, 1950, Vol. 23: No. 4. Published monthly, with an additional issue in June, price 75¢ a copy for U. S. and possessions, and Canada; \$1.50 for Latin America; \$2.00 for all other foreign countries. Directory issue \$2.00. Allow at least ten days for change of address. All communications about subscriptions should be addressed to the Director of Circulation. Subscription rates—United States and possessions, \$6.00 a year, \$9.00 for two years, \$12.00 for three years, Canada (Canadian funds accepted), \$10.00 a year, \$16.00 for two years, \$20.00 for three years. Latin American countries \$15.00 for one year, \$25.00 for two years, \$30.00 for three years. All other countries \$20.00 for one year, \$30.00 for two years, \$40.00 for three years. Please indicate position and company connections on all subscription orders. Entered as Second Class matter August 29, 1936, at Post Office, Albany, New York, under the act of March 3, 1879. BRANCH OFFICES: 520 North Michigan Avenue, Chicago 11, Ill.; 68 Post Street, San Francisco 4; Aldwych House, Aldwych, London, W.C. 2; Washington, D. C. 4; Philadelphia 3; Cleveland 15; Detroit 26; St. Louis 8; Boston 16; Atlanta 3, Ga.; 621 So. Hope St., Los Angeles 14; 738-9 Oliver Building, Pittsburgh 22. ELECTRONICS is indexed regularly in The Engineering Index.



# Cross it Out!



## with new marion **ruggedized instruments**

The new Marion Ruggedized meters (Hermetically Sealed) now give you an exceptionally accurate and sensitive means for electrical measurement and indication — under extreme conditions of Shock, Vibration, Mechanical Stress, Strain, Weather Conditions and Climate. This whole new family of Ruggedized Panel instruments gives you new freedom of application. You can use them where you have never before dared use "delicate instruments." What's more, they meet the dimensional requirements of JAN I-6 and are completely interchangeable with existing standard JAN 2½" and 3½" types.

When you need ruggedized meters for rugged applications; when you need special meters for special applications; when you need *better* meters for *any* application . . . call on Marion — the name that means the *most* in meters.

Send for your free copy of our booklet on the New Marion Ruggedized Instruments today. Marion Electrical Instrument Company, Manchester, New Hampshire.



Manufacturers of  
Hermetically Sealed  
Meters Since 1944



**MARION MEANS THE MOST IN METERS**

Canadian Representative: Astral Electric Company, 44 Danforth Road, Toronto, Ontario, Canada  
Export Division: 458 Broadway, New York 13, U.S.A., Cables MORHANEX

# marion meters

Copr. 1950 Marion Electrical Instrument Co.



## Phonic Motors and Timing Devices

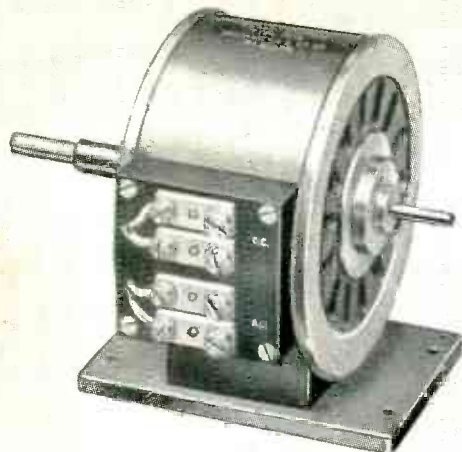

Designed for use at frequencies from 50 c/s - 2000 c/s. Phonic Motors of this type form the nucleus around which are built the timing devices illustrated on this page.



The Timing Device Type D-199-A provides an impulse of 1/10 second duration once every second, when the motor is supplied with power at a frequency of 1000 c/s.

The Timing Device Type D-193-A provides an impulse of 1/10 second duration 61 times per minute and, in addition, an impulse of 1/2 second duration once per minute. A worm and wheel adjustment allows phasing correction.

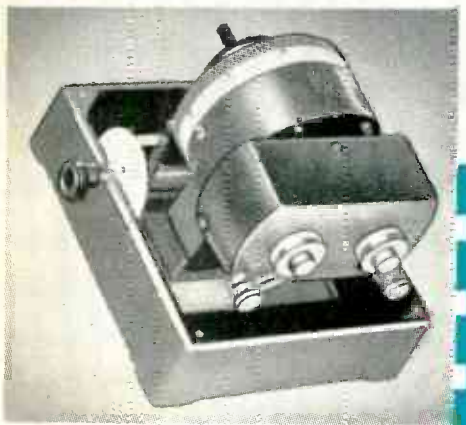

In many branches of scientific work the need arises for a motor capable of a very high standard of constancy of speed. The frequency of the mains electricity supply is not normally controlled to better than one or two per cent., so that a mains-operated synchronous motor may be inadequate, and centrifugal governors, as used on gramophone motors, may not provide a sufficiently precise control. In such cases a phonic motor driven by an alternating current supply of high frequency stability may be employed. It is not perhaps generally realized that in their modern form such motors may be used to give quite a large torque, and are able to maintain synchronism despite the sudden imposition of relatively large inertia loads. Under steady-state conditions, "hunting" is almost entirely eliminated, and the constancy of rotational speed is almost entirely dependent on the frequency stability of the alternating current supply.

A precision quartz crystal controlled frequency of 100 kc/s may attain a frequency stability of the order of one part in  $10^8$ . This frequency is then divided electronically to 1,000 c/s by means of regenerative dividers or locked multivibrators. In order to facilitate comparisons with time signals, or to use the frequency standard as a clock, it is necessary to derive a still lower frequency—preferably one cycle per second. Electronic division in the range 1,000 to 1 cycle per second, with high phase stability, is difficult, and the simplest and most reliable method is to drive a phonic motor from the 1,000 c/s source, and to fit mechanical contacts to suitably geared driven shafts. An added advantage is that by employing further gearing, more widely spaced signals may be obtained. Thus signals spaced at intervals of one sidereal second, or any other specified interval, may be obtained from an oscillator with a fundamental frequency of 100 kilocycles per mean time second. By means of a simple mechanical device, controlled changes in phase of the timing of the contacts are also possible.

### MOTOR TORQUE

The earliest form of phonic motor consisted

# Are You

## ON OUR MAILING LIST

for

# TECHNIQUE

A JOURNAL OF INSTRUMENT ENGINEERING



## IF NOT MAIL COUPON

# NOW



MUIRHEAD & CO. LTD · BECKENHAM · KENT · ENGLAND

Please mail me, free of charge, your quarterly journal "TECHNIQUE"

NAME

POSITION

COMPANY

ADDRESS

# MUIRHEAD & Co. LTD.

PRECISION ELECTRICAL INSTRUMENT MAKERS  
BECKENHAM · KENT · ENGLAND

Telegrams and Cables: MUIRHEADS ELMERS-END

PRECISION  
**MUIRHEAD**  
ELECTRICAL INSTRUMENTS

MU.26

IRC

# Age is

## for resistors too!

20 years ago, IRC advertised resistors for *television!*  
 And right now, while we produce for today's requirements, electronics 1970 is on our drawing boards. 25 years young this year, IRC combines a quarter-century of specialized engineering with free, fresh thinking on new resistance problems. Result of this concentration:—A unique variety of high-quality, lower-cost resistance products, plus *unbiased* recommendations.



### TELEVISION IN 1930

Advertising resistors for television 20 years ago was not nearly so advanced as IRC's present planning for the future.



# important



**LESS THAN 3%** change from original value due to aging has been proven for MV High Voltage Resistors. The resistance coating of Type MV's is stabilized at high temperature. Application of this filament coating in helical turns on a ceramic tube gives a conducting path of long effective length and permits the use of up to 100,000 volts for the MVR resistor. For high voltages where high resistance and power are required Type MV's are available in a wide range of values, sizes and terminals, all described in Bulletin G-1. Use the coupon to get your copy.

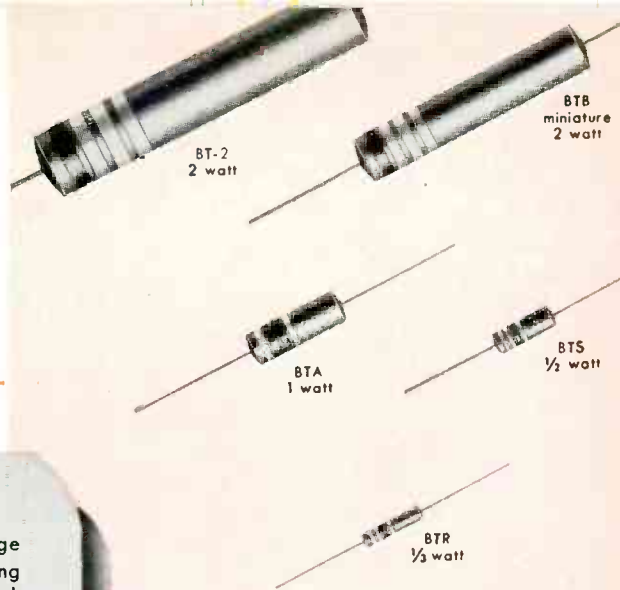

## AGING IS NO PROBLEM

with Advanced BT Resistors. Filaments are pre-cured and stabilized, practically eliminating any possibility of resistance change through aging. Engineered to meet JAN-R-11 specifications for fixed composition resistors, IRC BT's have established their superiority in all important characteristics. Let us prove it to you... check the coupon for 12 page technical data Bulletin B-1. 21 characteristic charts compare IRC performance to rigid JAN specifications.

## AFTER 10,000 CYCLES

of rotation IRC's new Q Control shows less than 10% change in resistance for values below 1 megohm, and not over 15% change for values of 1 megohm and above. Noise level after the same rigorous tests remains well within the industry standard for new controls. Investigate the many advantages of this modern size 15/16" diameter control. Complete mechanization in manufacture assures you of absolute uniformity and a dependable source of supply. Coupon brings you full details on Bulletin A-4.

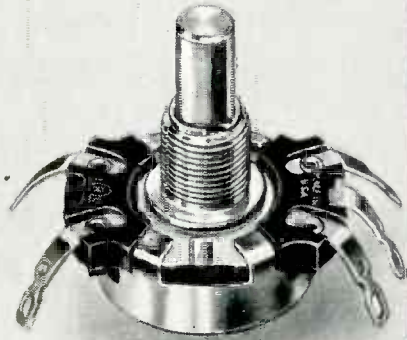

**INTERNATIONAL  
RESISTANCE COMPANY**

401 N. Broad Street, Philadelphia 8, Pa.

In Canada: International Resistance Co., Ltd., Toronto, Licensee

*Wherever the Circuit Says*

Power Resistors • Voltmeter Multipliers  
• Insulated Composition Resistors • Low  
Wattage Wire Wounds • Controls  
• Rheostats • Voltage Dividers •  
Precisions • Deposited Carbon  
Precisors • High Frequency and High  
Voltage Resistors • Insulated Chokes

**INTERNATIONAL RESISTANCE CO.**  
403 N. BROAD ST., PHILADELPHIA 8, PA.

Please send me complete information on the items checked below:

- MV High Voltage Resistors (G-1)  New Q Controls (A-4)  
 Advanced BT Resistors (B-1)  Name of Local IRC Distributor

NAME.....

TITLE.....

COMPANY.....

ADDRESS.....



**Top Products in Every Line  
Cut Costs and Build Sales  
with AMERICAN PHILLIPS SCREWS**

**HOW THEY CUT COSTS:** From vacuum cleaners to vending machines; from trucks to office appliances and suntan lamps . . . manufacturers use American Phillips Screws to speed up production, stop spoilage, and cut unit-costs. For these modern fastenings banish fumbling, crooked driving and scarred surfaces . . . *cut assembly time as much as 50%.*

**HOW THEY BUILD SALES:** On any product, the crossed-recess of American Phillips Screws is a "green light" to buyers who stop and look for an outward index of inward quality. They know that smooth-headed American Phillips Screws protect product-performance by staying tight

and resisting vibration. Does *your* product have these two American Phillips advantages of cost-reduction and sales-promotion? No reason why it shouldn't . . . *for American Phillips Screws always cost least to use. Write for proof.*

**AMERICAN SCREW COMPANY, Main Office: Providence 1, R. I.**  
Plants at Willimantic, Conn., and Norristown, Pa.  
Warehouses at: Chicago 11: 589 E. Illinois St. Detroit 2: 502 Stephenson Bldg.

AMERICAN  
PHILLIPS

Screws



**ALL TYPES**  
ALL METALS: Steel,  
Brass, Bronze, Stain-  
less Steel, Aluminum,  
Monel, Everdur (sil-  
icon bronze)



**MACHLETT**

*... makes the Difference!*



**Look to the Specialist**

**in Tube Production**

**... for Better Tubes**

**... for Technical Progress**

*Example...*

**ADVANCED**

**VACUUM TECHNIQUES**

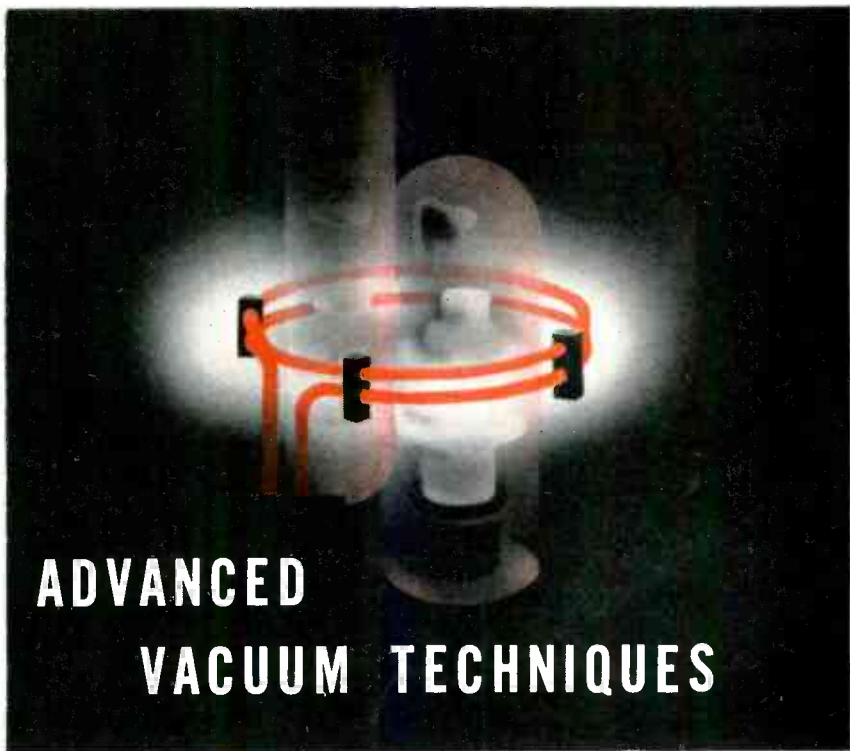

Two electron tubes may look exactly alike, their ratings and operating characteristics may be similar, but their processing in manufacture can—and does—result in a fundamental difference between them. For it is the things you can't see in a tube, the intangibles—which are as important as the physical structure itself—that ultimately determine the tubes' true worth. It is the ability of the manufacturer to understand the problems involved and to effectively solve them through the application of all the skills at his disposal—skills which can only be gained through specialization and long years of experience.

Machlett Laboratories has these skills—acquired in over half a century of electron tube experience.

Its unique series of vacuum techniques—the essential elements in electron tube manufacture—is an outstanding example of the importance of the “unseen” in tube performance and life. Machlett standards—based on long experience—require more than the conventional “pumping” or “exhaust” procedure. High voltage exhaust, rigorous pre-exhaust vacuum firing and the ex-

treme in sanitary techniques are standard practice on all Machlett tubes. In many instances final seals are made by Machlett's unique method of R.F. brazing—thus eliminating the usual flame-formed glass to glass seal and so providing greater freedom from contamination of internal structures and misalignment of electrodes.

These “plus” features are not necessary to the production of average—or even good—tubes. They are essential, however, to producing the best the art now makes possible.

This is just one example of Machlett's ability, one of the many advantages you gain from Machlett's long experience devoted solely to the manufacture of the highest quality electron tubes.

If you are contemplating the installation of new equipment or replacing your present tubes, it will pay you to...

*“Look to the Tube Specialist”*

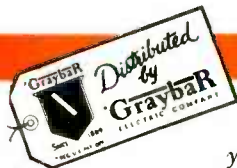

**OVER 50 YEARS OF ELECTRON TUBE EXPERIENCE**

**MACHLETT**

*For information regarding available tube types, consult your local Graybar representative or write direct to Machlett Laboratories, Inc., Springdale, Conn.*

# ONLY 7 MILLIAMPERES IN COIL CONTROLS 5-AMPERE CONTACT!

## New ADLAKE No. 5000 SENSITIVE RELAY



Because of its amazingly high load-input ratio, the No. 5000 relay operates at 115 volts 60 cycles on *only 0.007 ampere*—a fraction of the current consumed by any other type of mercury relay! With this low amperage operating the coil, the contacts will handle 5 amperes at the same voltage! And tests indicate the No. 5000's life to be over *30 million operations!*

Designed especially for sensitive thermo-regulation, it is ideally suited for use in electronic tube circuits where the output of the tube is limited. It can be used as a pilot relay operating from a very sensitive thermo-regulator—serves equally well for high and low temperature control—and functions perfectly with either mercury-and-glass or bi-metal regulators.

FOR FULL INFORMATION on this sensational relay, write The Adams & Westlake Company, 1107 N. Michigan, Elkhart, Indiana. No obligation, of course.

### Every **ADLAKE** Mercury Relay Brings You These Advantages!

- Hermetically sealed—(dust, dirt, moisture, oxidation and temperature changes can't interfere with operation)
- Silent and chatterless
- Requires no maintenance
- Absolutely safe

THE  
**Adams & Westlake**  
COMPANY



Established 1857 ELKHART, INDIANA New York • Chicago

Manufacturers of Hermetically Sealed Mercury Relays for Timing, Load and Control Circuits



No. 3  
of a  
Series

# Another Engineer's Problem Solved\*

**SUBJECT:** ZERO TEMPERATURE  
COEFFICIENT CAPACITORS



**PROBLEM:** Relatively large capacitances (.01 to .5 Mfd.) were required for a 400 cycle resonant filter, for operation from  $-60^{\circ}\text{C}$  to  $+75^{\circ}\text{C}$ .



**SOLUTION:** Plasticon AS Capacitors have a positive temperature coefficient of 1000 parts per million per degree Centigrade. Plasticon LS Capacitors are negative 1000 ppm/ $^{\circ}\text{C}$ . By combining matched capacitor elements of each type in a single container, temperature coefficients from plus 1000 ppm to minus 100 ppm/ $^{\circ}\text{C}$  can be supplied.



A .25 mfd capacitor for 440 VAC, 400 cycle operation Type (AL) SC254-44X measures  $1\frac{3}{4}'' \times 1'' \times 2\frac{1}{8}''$  high. Type (AL) Capacitors can be furnished from 330 VAC and higher; from .01 mfd. and up.



What is YOUR engineering problem? Your inquiries will receive immediate attention.



*We manufacture a standard line of Plasticon Capacitors, Pulse Forming Networks and High Voltage Power Supplies. Write for our catalog.*

## Condenser Products Company

1375 NORTH BRANCH STREET • CHICAGO 22, ILLINOIS

**MITCHELL-RAND** announces....

# 1766EX

## CAPACITOR END FILLER

### FOR SEALING OIL, WAX AND ELECTROLYTIC PAPER TUBE CAPACITORS

it's new • it's better • it's low cost

Once again Mitchell-Rand demonstrates the effectiveness and value of its research and development as it produces 1766EX, a resin base thermoplastic having high cold flow, solid adhesion, inflexible oil resistance, absolute sealing and low-cost characteristics, all superior to any like product now available. 1766EX is the product long required by manufacturers of paper tube capacitors that must be guaranteed for operating temperatures to 105°C.

Yes, once again Mitchell-Rand gives point to its repute as "Headquarters for Everything in Electrical Insulation"!

1766EX adds another to Mitchell-Rand's more than 3500 compound and wax formulas that resist high voltage breakdown, salt spray atmosphere, humidity, cracking or flaking, acids and alkalis, with excellent flexibility and adhesive qualities, high cold flow and good thermal conductivity, waxes that penetrate fibre, floss, bakelite, paper and cloth and with low viscosity, high surface tension and good electrical characteristics. Mitchell-Rand has the compound or wax to meet your specific requirements and should the need arise for a special formula to meet a particular condition, then Mitchell-Rand will create the compound embodying every quality required.

#### SPECIFICATIONS

<b>COLD FLOW (M-R)</b>	— 250/255 F
<b>S.P. (B&amp;R)</b>	— 255/260 F
<b>POURING TEMPERATURE</b>	— 350/400 F
<b>COLOR</b>	— Brown
<b>ADHESION</b>	— Good
<b>PENETRATION 77/100/5</b>	— 0
<b>CHLORIDE CONTENT</b>	— *Negative
<b>SPECIFIC GRAVITY</b>	— 1.59
<b>FLASH POINT</b>	— 490 F
<b>MINERAL OIL RESISTANCE</b>	— Good

\*Less than 4 parts per million.

#### FEATURES

##### ADHESION TO WAX IMPREGNATED TUBES:

In developing 1766EX every effort was made to assure good bonding properties to wax impregnated tubes without sacrificing hardness at high temperatures (100°C).

##### MINERAL OIL RESISTANCE:

Since penetration of mineral oil from oil impregnated and oil cooled capacitor sections tend to soften end fill compositions, 1766EX was formulated to resist mineral oils.

##### LOW COST:

In order that its adaptability be extended to almost every end sealing application, attractive low cost was included as a prime factor in the development of 1766EX and without the sacrifice of any quality feature.

##### COLD FLOW:

The high cold flow temperature of #1766EX permits its use for paper tube capacitors which are guaranteed for operating temperatures up to 105°C. Employing the standard container specified for the standard M-R Cold Flow test (2" in diameter by 1 3/8" high filled to depth of 1") 1766EX will resist cold flow at 115°C for more than 24 hours.

##### APPLICATION CHARACTERISTICS:

Sealing of capacitors with 1766EX is facilitated by the low pouring viscosity and good bubble release which this seal exhibits. The relatively sharp melting point and special filler combination of 1766EX permit easy pinhole repair. These properties make 1766EX particularly well suited for sealing electrolytic units.

Write for your laboratory test sample... free upon request.

M-R THE ELECTRICAL INSULATION HEADQUARTERS FOR 60 YEARS.



## MITCHELL-RAND INSULATION CO. Inc.























51 MURRAY STREET • Cortland 7-9264 • NEW YORK 7, N. Y.

A PARTIAL LIST OF M-R PRODUCTS: FIBERGLAS VARNISHED TUBING, TAPE AND CLOTH • INSULATING PAPERS AND TWINES • CABLE FILLING AND POTHEAD COMPOUNDS • FRICTION TAPE AND SPLICE • TRANSFORMER COMPOUNDS • FIBERGLAS SATURATED SLEEVING • ASBESTOS SLEEVING AND TAPE • VARNISHED CAMBRIC CLOTH AND TAPE • MICA PLATE, TAPE, PAPER, CLOTH, TUBING • FIBERGLAS BRAIDED SLEEVING • COTTON TAPES, WEBBINGS AND SLEEVINGS • IMPREGNATED VARNISH TUBING • INSULATED VARNISHES OF ALL TYPES • EXTRUDED PLASTIC TUBING

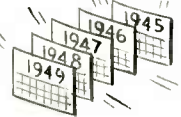

# ADVENTURES IN ELECTRONIC DESIGN

## Centralab's Special Electronic Component Parts Design Service May Solve a Problem for You

How many times  have your design engineers  been called  upon to develop new equipment only to be faced with a new bug  — or special problem of one variety or another? Everything about the new gadget seems  but you need a special part to lick  the special problem. To Centralab Engineers  these queer bugs  and special problems are as welcome as a Rolls Royce  to a burlesque queen . They look on these problems as their own  and from their bag  of 30 years of electronic experience — they always come up with an answer.  Take a look  over the next two pages . See for yourself  some of these "Specials" in ceramics,  switches  and capacitors  that CRL  has developed to meet special needs during the past few years . Maybe you'll see one that can help  — or you'll know where to go with your next special problem.  of course!

**Centralab** — DEVELOPMENTS THAT CAN HELP YOU 

Division of GLOBE-UNION INC. • Milwaukee

# What's your need in

APRIL 1950

Centralab  
offers 30 years  
experience in  
special electronic  
part design and  
manufacture

## Define your problem— bring it to Centralab

If you have an unusual electronic or ceramic part design and fabrication problem — bring it to Centralab. It may very well happen that with a combination of standard CRL parts — or a slight modification thereof — we can help you solve it. If special requirements warrant — we can design a completely new unit and produce it for you. All we need is your exact requirements as to purpose, size, capacity, voltage and resistance. Write Dept. "E" outlining your problem. No obligation. Centralab Division, Globe-Union Inc., 900 E. Keefe Ave., Milwaukee 1, Wisconsin.

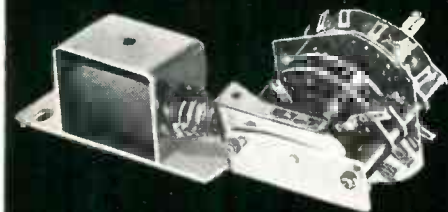

**1** A solenoid operated selector switch.

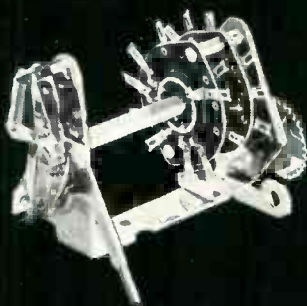

**2** Automatic selector switch for automobile radio.

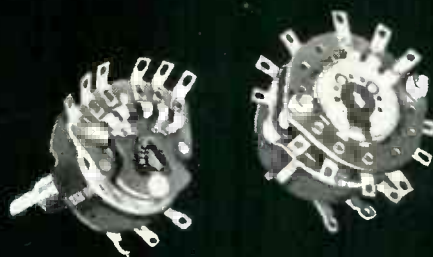

**3** Combination control and selector switches.

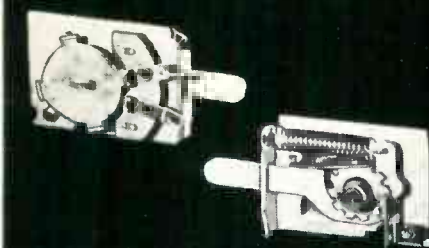

**4** Front and rear view—push button type tone switch.



**5** Left — dual TV Trimmer. Right — TV trimmer combined with ceramic coil form.

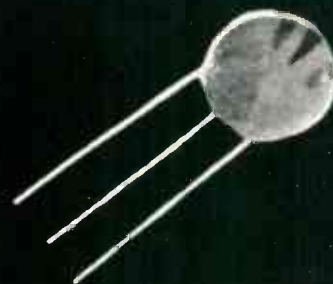

**6** 5000V dual disc ceramic capacitor. Actual size, slightly larger than a nickel.



**7** Special tubular ceramic capacitor — 2200 MMF  $\pm$  1%.



**8** Control with offset shaft and operating gears.

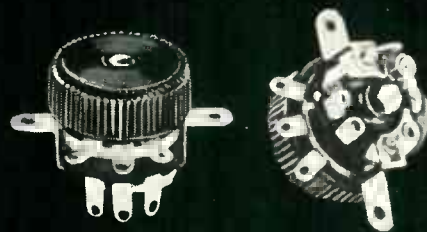

**9** Front and rear view — Centralab's miniature (smaller than a dime!) Dual Model 1 Control.



# Special Electronic Parts?



**10** Examples of special "printed circuit" parts. Left — a fixed value capacitor. Right — an inductance coil.

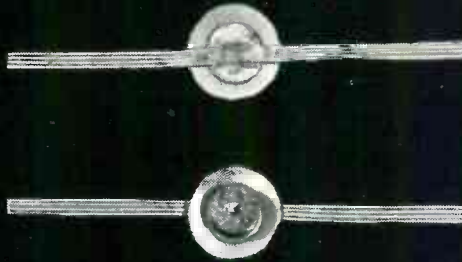

**11** Front and rear view — special type by-pass capacitor.

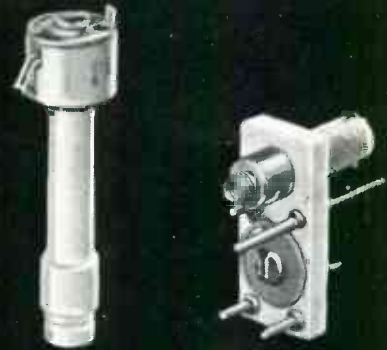

**12** Special ceramic coil form and trimmer assembly.



**13** Steatite ceramic coil form with bonded metal end.



**14** Centralab Steatite ceramic used in special forms — coils etc.

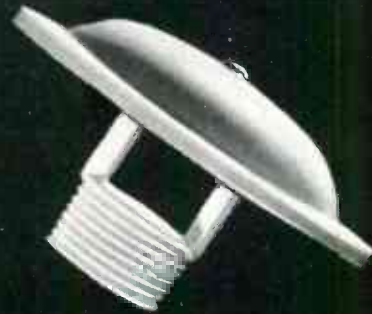

**15** CRL Steatite used as part of diffusion system in hot water heater.



**16** Special feed-thru by-pass capacitor.

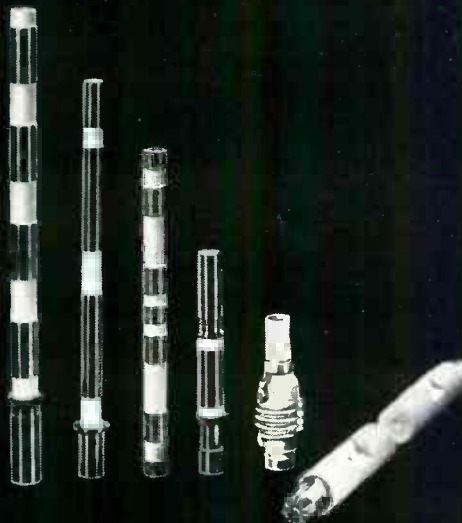

**18** Metallized ceramic rods for rotor sections in hi-voltage variable transmitter capacitors, and resonant lines.

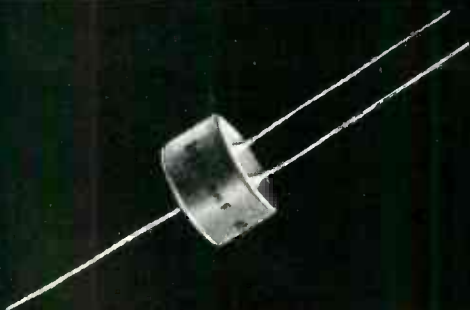

**17** Special 5-10 KV hi-voltage capacitor.

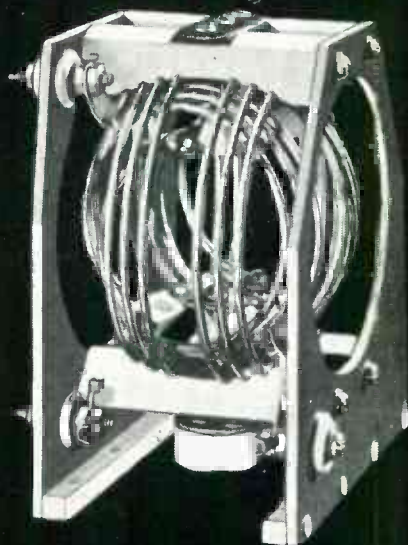

**19** Special antenna loading variometer.







# NEW HYTRON 12BH7

does more for less

- **Ideal Sweep Amplifier**
- **Higher-Perveance Twin Triode**
- **Designed for TV**
- **Permits Lower-Cost TV Sets**
- **Another Hytron TV First**

Here's another Hytron original you'll be buying soon. New 12BH7 twin triode is enthusiastically hailed as tops for sweep circuits by leading makers of TV sets. One half 12BH7 sweeps wide-angle 16-inch picture tube at 14 kilovolts. One section alone matches performance of: Paralleled 6SN7GT. Or equivalent single triode. Or triode-connected beam pentode. Other half of 12BH7 is free for other uses—such as blocking oscillator.

How does Hytron do it? Higher perveance (lower tube loss)? Yes. Also the Hytron 12BH7 is: designed for TV. Rated for TV. Tested for TV. Again a Hytron TV first. Again a Hytron contribution to lower-cost TV for the mass market. Watch for the 12BH7. Write for Bulletin E-149.



### AND NOW THE HYTRON

**16TP4** Another Hytron 16-inch rectangular picture tube. Follows closely on heels of original Hytron rectangular tube, the 16RP4. Write for Bulletin E-150 for complete data. Watch also for early announcements of new Hytron 14-inch and 19-inch rectangular tubes.

### MODERN LOW-COST 16-IN. DESIGN

A Hytron contribution to lower TV costs. All-Hytron: 1X2, 6BQ6GT, 6U4GT, 12BH7, 16TP4 or 16RP4. For application and circuit details, write for Bulletin E-151.

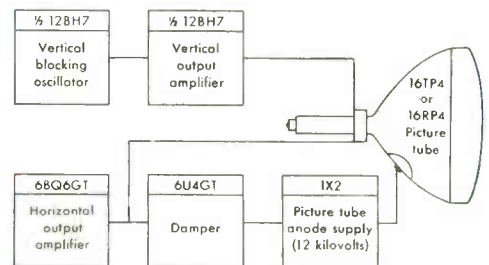

OLDEST MANUFACTURER OF RECEIVING TUBES  
**HYTRON**  
RADIO AND ELECTRONICS CORP.

MAIN OFFICE: SALEM, MASSACHUSETTS

# PRECISION ATTENUATION to 3000 mc!



\*Patents applied for

Inquiries are invited concerning single pads and turrets having other characteristics

- VSWR less than 1.2 at all frequencies to 3000 mc.
- Turret Attenuator\* featuring "Pull — Turn — Push" action with 0, 10, 20, 30, 40, 50 DB steps.
- Accuracy  $\pm .5$  DB, no correction charts necessary.
- 50 ohm coaxial circuit. Type N connectors.

**STODDART AIRCRAFT RADIO CO.**

6644 SANTA MONICA BLVD., HOLLYWOOD 38, CALIFORNIA  
Hillside 9294



**BRUSH  
INSTRUMENT  
REPRESENTATIVES**



**W. A. BROWN & ASSOC.**  
3102 S. Hayes Street  
Arlington, Virginia  
Otis 8516

**BURLINGAME ASSOC.**  
103 Lafayette Street  
New York 13, New York  
DIgby 9-1240

**RUSSELL COLDWELL**  
289 Fairfield Avenue  
Hartford, Connecticut  
2-5832

**FOSTORIA IND. SERVICE**  
1730 Pine Street  
St. Louis, Missouri  
Central 0153

**JAMES L. KEARNS**  
Electronic Specialties Reps.  
331 S. E. 62nd Avenue  
Portland 16, Oregon  
East 4331

**ARMIN LEICH**  
3832 Carrollton Avenue  
Indianapolis, Indiana  
Talbot 7141

**HUGH MARSLAND**  
20 No. Wacker Drive  
Chicago 6, Illinois  
ANdover 34984

**GERALD B. MILLER**  
1051 N. Havenhurst Drive  
Hollywood 28, California  
(P. O. Box 1471)  
Hollywood 6305-6306

**M. P. ODELL**  
2536 Euclid Avenue  
Cleveland, Ohio  
PRospect 6171

**H. M. RICHARDSON**  
2210 Foshay Tower  
Minneapolis 2, Minnesota  
Geneva 4078

**ANTHONY R. SATULLO**  
7635 E. Jefferson Avenue  
Detroit 14, Michigan  
MElrose 1508

**J. Y. SCHOONMAKER**  
2011-13 Cedar Springs Ave.  
Dallas 1, Texas  
Central 5535

**A. C. WICKMAN, LTD.**  
P. O. Box 9, Station "N"  
Toronto, Ontario, Canada  
LYndhurst 5415



# 60 CYCLES ON THE NOSE!

## BRUSH FREQUENCY GENERATOR fixes speed of synchronous motors

**T**HE BRUSH MODEL BL 809 Regulated Frequency Power Supply furnishes moderate power at 60 cycles that is completely unaffected by the frequency of the primary power source. It will govern the operation of fractional horsepower synchronous motors at fixed speed or set the characteristics of controls where accurate frequency is essential. No adjustments are needed for any loading from zero to full capacity of 60 watts.

Designed for continuous, unattended operation, the Brush Regulated Frequency Power Supply acquires frequency stability from a

temperature-compensated tuning fork. Frequency accuracy is one part in 100,000. For example, under normal conditions it will operate a synchronous electrical clock system with a time accuracy of less than one minute per month—despite variations in input frequency.

This Regulated Frequency Power Supply is engineered throughout for safe, dependable operation and is housed in a weatherproof, baked enamel, steel case, fitted with sturdy handles for easy portability. Write for complete information and specifications.

### THE *Brush* DEVELOPMENT COMPANY

3405 Perkins Ave., Cleveland 14, Ohio, U. S. A.

*(Models are also available for stabilization of frequencies other than 60 cycles)*

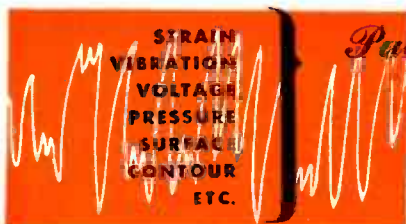

*Put it in writing with a*

# BRUSH RECORDING ANALYZER

STRAIN ANALYZERS • SURFACE ANALYZERS • CONTOUR ANALYZERS • UNIVERSAL ANALYZERS • UNIFORMITY ANALYZERS





# Designers

where  
timing  
is  
everything

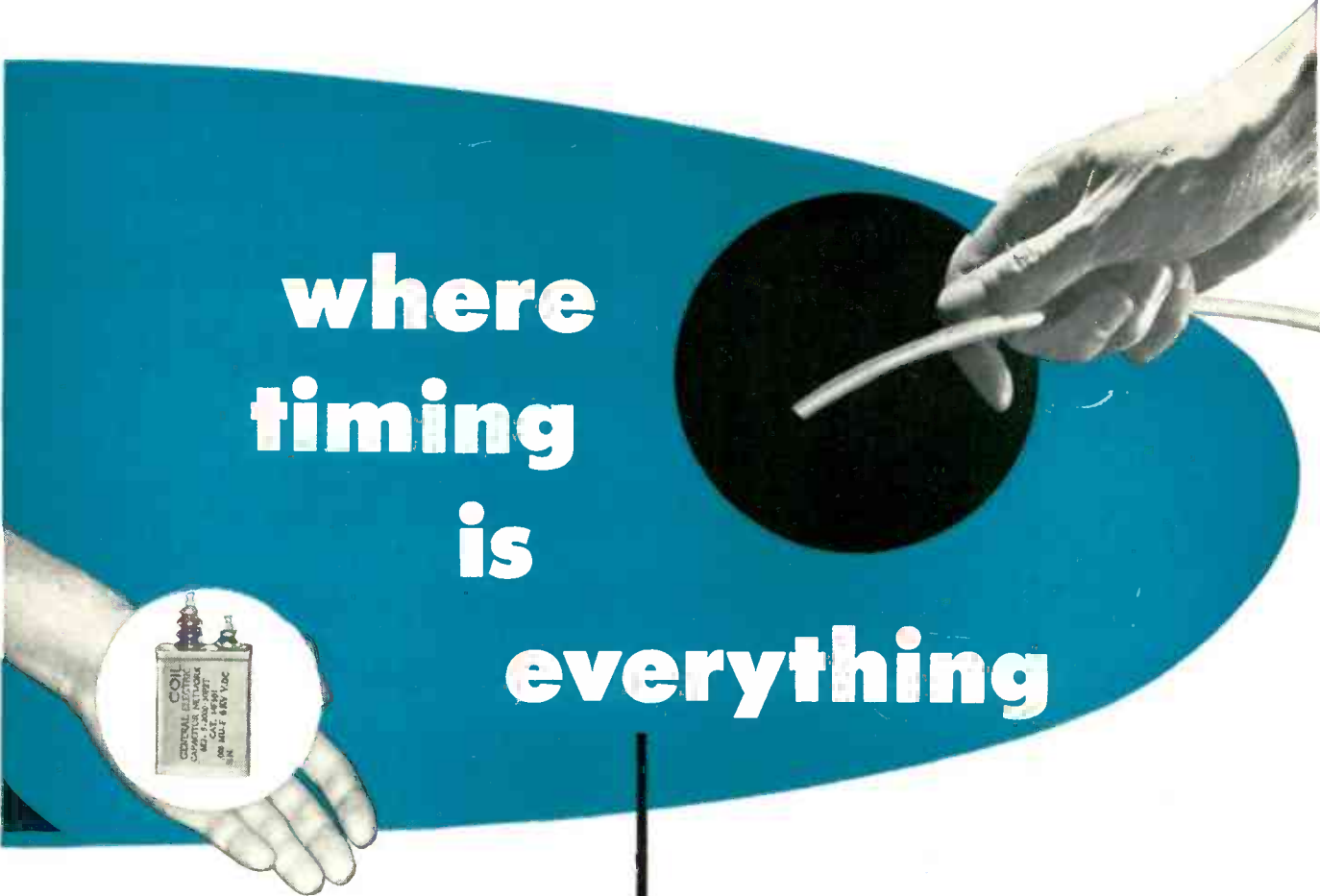

### **NEW! MIDGET, HIGH-TEMPERATURE PULSE-FORMING NETWORKS**

Here's a new, extremely compact and lightweight capacitor pulse-forming network that will operate at temperatures up to 120° C! With a volume of 6 cubic inches, it's just about one third the size of a conventional network with the same rating (6E2-5-2000-50-P2T).

The life expectancy of this 6-kv unit ranges from 3.5 hours at 80° C ambient to 1 hour at 110°. A second new network twice this size has a life of about 330 hours at 100° C—9 hours at 120° C. If you want more data on these new units, write *Capacitor Sales Division, General Electric Company, Pittsfield, Mass.*

### **DELAY LINES—BY THE FOOT**

These G-E delay lines provide a means for delaying signals with a band-width up to 2-megacycles for any time interval from .25 to 10.00 microseconds. They are available in bulk form in lengths up to 100 feet—delay equals approximately 1/2 microsecond per foot. Characteristic impedances of 1100 and 400 ohms per foot are available. Since the line is very flexible, it may be bent into 4-inch diameter coils.

Ordering line in bulk form makes it possible for you to cut it to the exact length required for your particular application. For complete ratings and specifications, see Bulletin GEC-459.

**GENERAL**  **ELECTRIC**



# Digest

## TIMELY HIGHLIGHTS ON G-E COMPONENTS

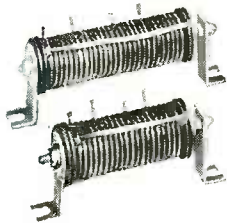

### MORE COMPACT RECTIFIER STACKS

If your requirements call for compact selenium stacks for operation in cramped quarters, these new, higher-voltage G-E selenium cells may be your answer. Their 18-volt d-c output means you can design stacks which are about 25% smaller than possible with 12-volt cells. The improved aging characteristics of these cells is made possible by a new G-E evaporation process which deposits selenium on aluminum with greater uniformity. Stacks are available with rated outputs of 18 to 126 d-c volts at 0.15 to 1.20 amperes with inputs of 23 to 180 a-c volts. See Bulletin GEA-5280.



### TIME METERS—TO CHECK TUBE LIFE

G-E time meters, with dependable Telechron\* motor drive, are especially useful in recording the operating time of radio transmitters or other electronic devices so that tubes may be replaced before they fail. They record operating time in hours, tenths of hours, or minutes, and are supplied for 11-, 115-, 230-, or 460-volt operation. The case is of molded textolite to harmonize with other G-E 3½-inch instruments mounted on the same panel. You'll find more description along with dimensions and pricing information in Bulletin GEC-472.

\*Reg. U.S. Pat. Off.

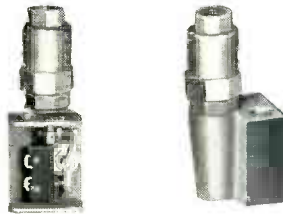

### NEW! WATER-FLOW INTERLOCK

This new G-E flow interlock provides sure protection against overheating in water-cooled components such as tubes, transformers, and dynamotors. Its function is to open the electrical circuit when water flow is lower than a preset minimum and close it when flow is above this point.

Adjustment can be made to actuate the electrical contact for any flow between 1 gallon per minute and 4 gallons per minute. The cut-in, cut-out differential of the unit is 0.2 gpm. The electrical circuit is rated at 10 amperes at 125 volts a-c, 5 amperes at 250 volts a-c and 3 amperes at 460 volts a-c. Maximum water-line pressure rating is 125 pounds per square inch. The unit is bronze with standard ½-inch fittings and is easy to install and adjust. For further description see Bulletin GEC-411.



### NEW! BATTERY-OPERATED VTVM

This new G-E battery-operated electronic voltmeter combines the portability of an ordinary low-sensitivity multimeter with the high sensitivity and versatility of a line-voltage-operated vacuum-tube voltmeter.

Its weight is only 4 pounds (with batteries), its size—3"x6"x8", but it measures a-c and d-c voltage in 7 ranges from 0-1 to 0-1000 volts, d-c current in 4 ranges from 0-1 to 0-1000 milliamperes, resistance in 5 ranges from 100 ohms to 10 megohms, mid-scale value.

D-c input impedance is 11 megohms on all ranges. A-c input impedance is 0.5 megohm shunted with 20 mmf on all ranges. Frequency response is flat within 5 per cent up to 15,000 cycles on all up to and including the 0-100-volt range. More data in Bulletin GEC-622.

General Electric Company, Section A667-5  
Apparatus Department  
Schenectady 5, N. Y.

Please send me the following bulletins:

(Indicate:  for reference only;  for planning an immediate project)

- |   |   |
|---|---|
| <input type="checkbox"/> GEA-5280 Selenium rectifiers | <input type="checkbox"/> GEC-472 Time meters          |
| <input type="checkbox"/> GEC-411 Flow interlock       | <input type="checkbox"/> GEC-622 Electronic voltmeter |
| <input type="checkbox"/> GEC-459 Delay lines          |   |

NAME .....

COMPANY .....

ADDRESS .....

CITY ..... STATE .....

# **GLOBAL** TRADE MARK Type BNR Resistors Display Unusual **NON-LINEAR** Voltage-Resistance Characteristics

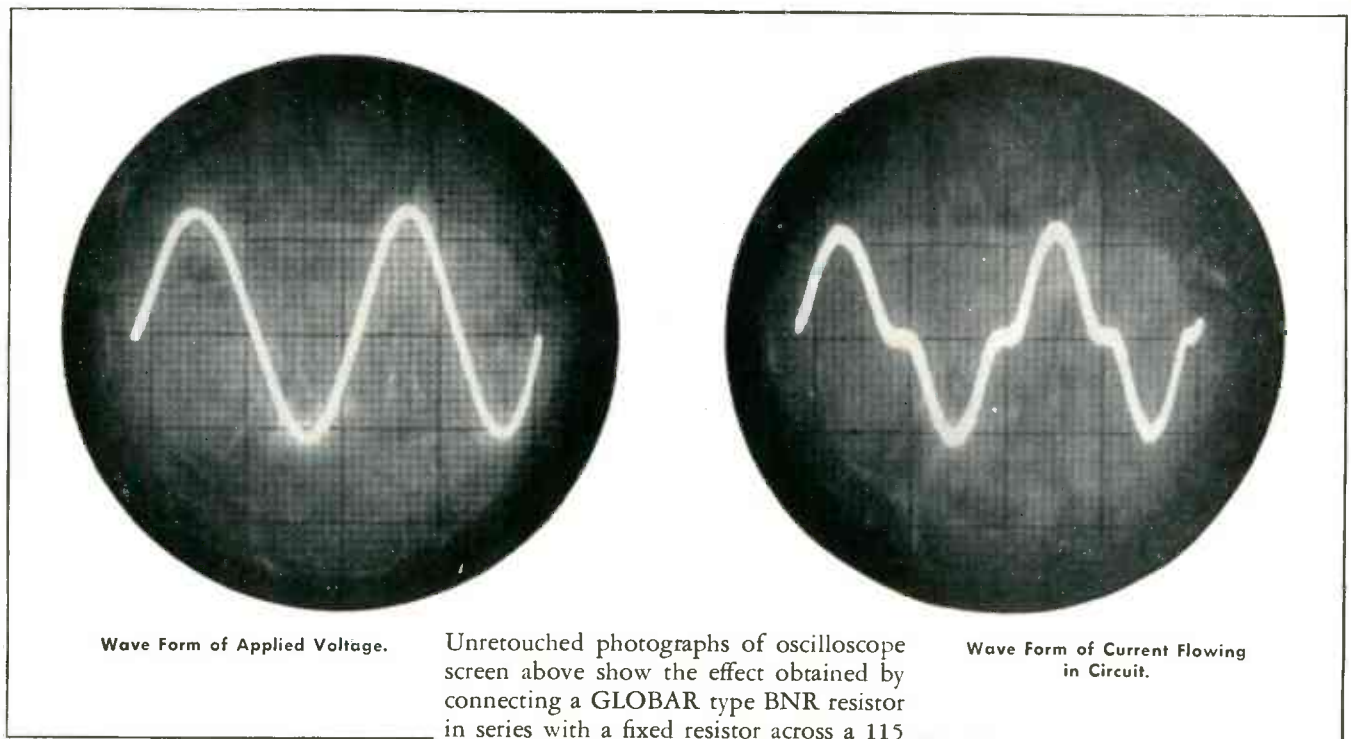

## Typical successful applications of BNR Ceramic Resistors include:

- 1** Oil burner ignition transformers to prevent high voltage feed back into line.
- 2** Small motors to prevent arcing of governor contact points.
- 3** Stabilizing rectifier circuits by limiting peak voltages.
- 4** Voltage control circuits in electronic devices.
- 5** Protection of solenoid valves in direct current circuits.

Bulletin GR-2 contains useful engineering data on GLOBAL Type BNR Ceramic Resistors. Copies will be supplied immediately upon request. Write Dept. V-40, The Carborundum Company, GLOBAL Division, Niagara Falls, N. Y.



# **GLOBAL** Ceramic Resistors

## **BY CARBORUNDUM**

TRADE MARK



"Carborundum" and "Global" are registered trademarks which indicate manufacture by The Carborundum Company



# FREED

## TRANSFORMERS & INSTRUMENTS

“PRODUCTS OF EXTENSIVE RESEARCH”



NO. 1060 VACUUM  
TUBE VOLTMETER



NO. 1030 LOW  
FREQUENCY "Q"  
INDICATOR



HIGH FIDELITY  
OUTPUT  
TRANSFORMERS



DISCRIMINATORS

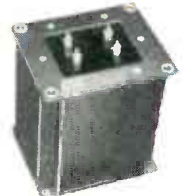

FILTER CHOKES



NO. 1140 NULL  
DETECTOR



NO. 1020 DIRECT  
READING  
MEGOHMETER

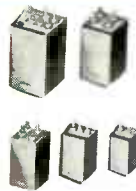

HERMETICALLY  
SEALED COMPONENTS



TOROIDAL INDUCTORS



HI-Q MINIATURE  
TOROIDAL INDUCTORS



NO. 1210 NULL  
DETECTOR & VACUUM  
TUBE VOLTMETER



NO. 1162 DECADE  
INDUCTOR



SUB-MINIATURE HI-Q  
HERMETICALLY  
SEALED  
INDUCTORS

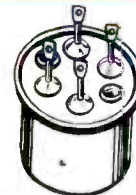

SUB-MINIATURE  
HERMETICALLY  
SEALED  
TRANSFORMERS

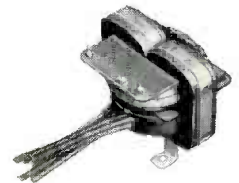

SPECIAL  
TRANSFORMERS



NO. 1050 UNIVERSAL  
BRIDGE



NO. 1010 COMPARISON  
BRIDGE



STEPDOWN  
TRANSFORMERS



CHOKES



POWER  
TRANSFORMERS



NO. 1040 VACUUM  
TUBE VOLTMETER



NO. 1110  
INCREMENTAL  
INDUCTANCE BRIDGE



FILAMENT,  
TRANSFORMERS



OUTPUT  
TRANSFORMERS



AUDIO  
TRANSFORMERS

SEND FOR LATEST CATALOG!

# FREED TRANSFORMER CO., INC.

DEPT. AE 1718-36 WEIRFIELD ST., (RIDGEWOOD) BROOKLYN 27, NEW YORK

# It is Our Privilege to serve the Leaders

**THIS FREE BOOK** — fully illustrated, with performance charts and application data — will help any radio engineer or electronics manufacturer to step up quality, while saving real money. Kindly address your request to Dept. 16.



## ANTARA® PRODUCTS

**GENERAL**  
**GA** NILINE & FILM CORPORATION

444 MADISON AVENUE  
NEW YORK 22, N. Y.

# G A & F® Carbonyl



**Manufacturers of**

**CARBONYL IRON POWDER CORES**

*( THE CORE IS THE HEART OF THE CIRCUIT )*

**Aladdin Radio Industries, Inc.**  
*Chicago, Illinois*

**Henry L. Crowley & Company, Inc.**  
*West Orange, New Jersey*

**Delco Radio Division**  
*General Motors Corporation*  
*Kokomo, Indiana*

**Lenkurt Electric Co., Inc.**  
*San Carlos, California*

**Magnetic Core Corporation**  
*Ossining, New York*

**National Moldite Company**  
*Hillside, New Jersey*

**Powdered Metal Products Corporation**  
*of America*  
*Franklin Park, Illinois*

**Pyroferric Company**  
*New York, New York*

**Radio Cores, Inc.**  
*Oak Lawn, Illinois*

**RCA Victor Division**  
*Radio Corporation of America*  
*Camden, New Jersey*

**Speer Resistor Corporation**  
*St. Marys, Pennsylvania*

**Stackpole Carbon Company**  
*St. Marys, Pennsylvania*

**Iron Powders . . .**



Another Rauland "First"!

# NEW "Indicator Gun" CR TUBE

Assures perfect ion trap magnet adjustment instantly  
... positively

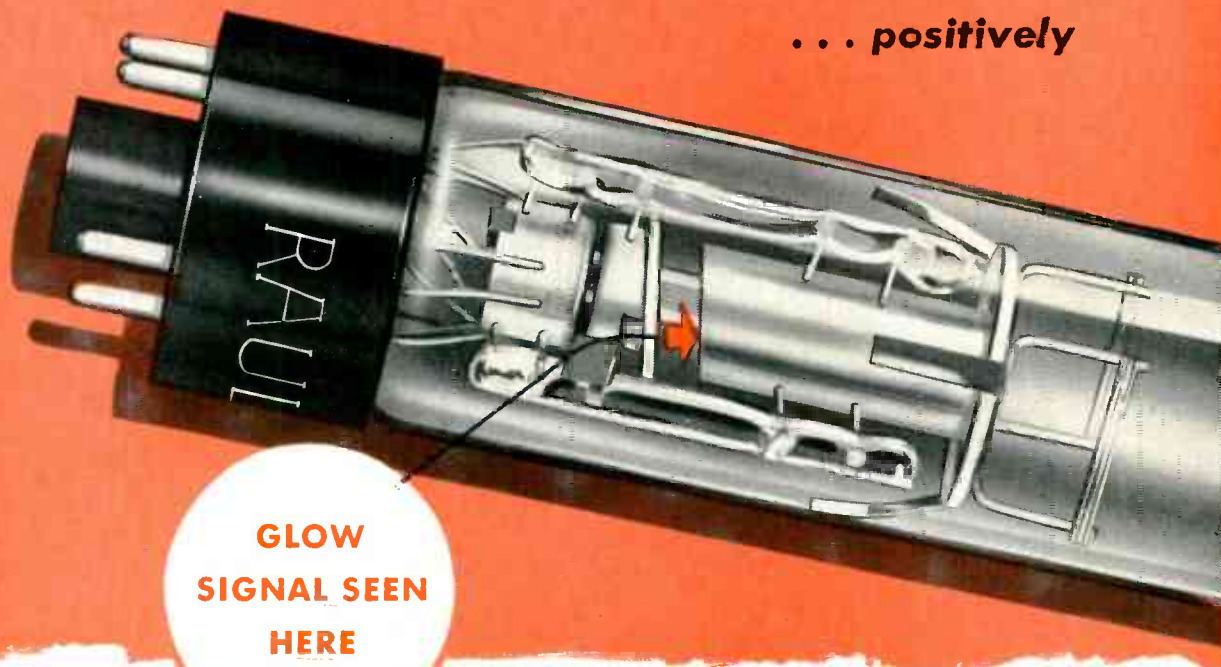

GLOW  
SIGNAL SEEN  
HERE

*Here at last—* is a fool-proof solution to the problem of ion trap magnet adjustment... a development which Rauland is happy to offer for the benefit of both set makers and service men.

The new Rauland "Indicator Gun"—patent pending—gives a brilliant visible signal easily seen from the rear of the set while magnet adjustment is being made. A bright green glow within the Anode Tube signals when adjustment is incorrect—dims as correct adjustment is approached—disappears when adjustment is correct.

All guesswork is eliminated—risk of screen damage through incorrect magnet adjustment is ended—and adjustment time is reduced to seconds. Assemblers or service men *know* that magnet adjustment is right—*know* that any remaining picture defect is in other controls.

The Rauland "Indicator Gun" adds nothing to the price of Rauland picture tubes. First production is in the 12LP4-A with Luxide Screen—available now!

## THE RAULAND CORPORATION



*Perfection Through Research*

4245 N. KNOX AVENUE • CHICAGO 41, ILLINOIS





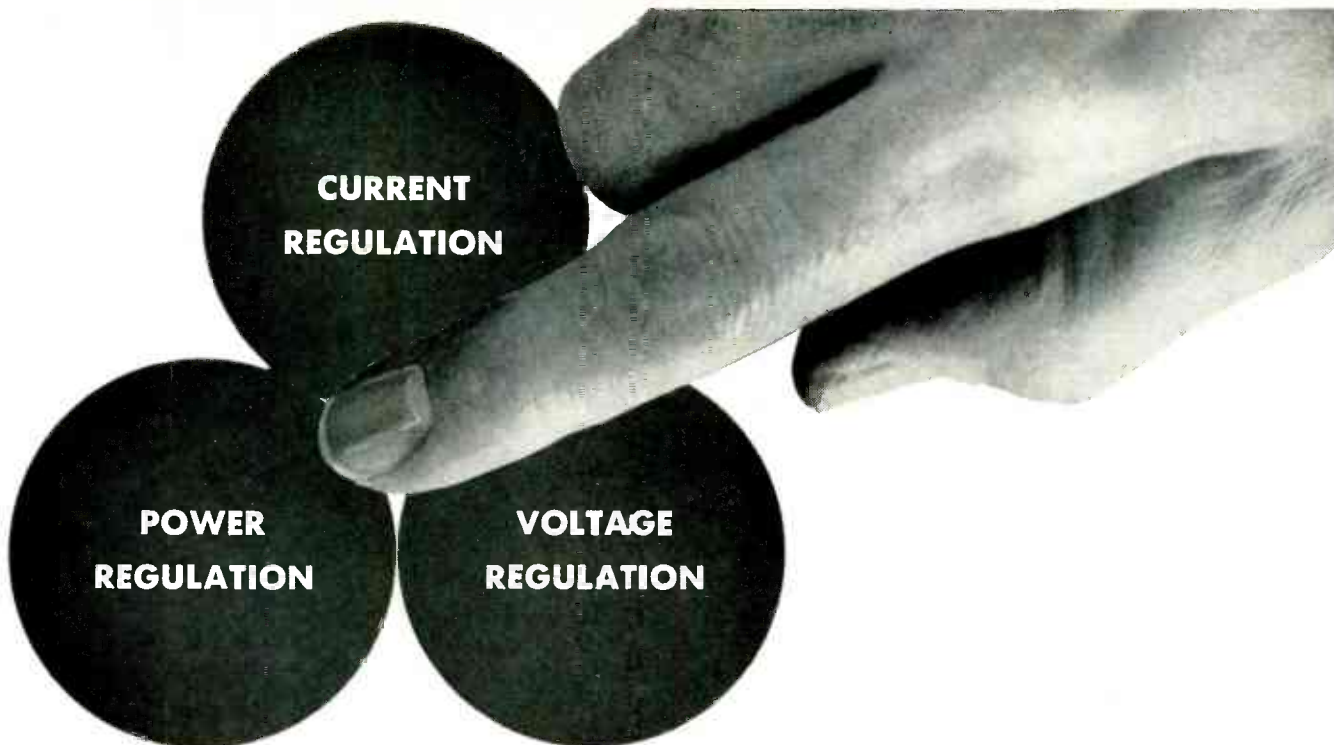

## can you put your *Finger* on the **TROUBLE?**

- If you can, a SORENSEN Electronically controlled, magnetic amplifier regulating circuit can solve it!

Sorensen's *new line* of Electronic AC Voltage Regulators is the *most accurate* and *most economical* line of Electronic Voltage Regulators on the market today. Standard specifications offer Accuracy to within  $\pm 0.1\%$  and Distortion as low as  $2\%$ . Load range from zero to full load. All models are temperature Compensated and can be supplied hermetically sealed or fosterited. And the Sorensen line uses *less tubes* than other electronic type regulators.

- Sorensen Engineers are always at your service to solve unusual problems and give you the benefits of years of experience. Describe your needs and let a Sorensen Engineer suggest a solution. It will save you time and money to try Sorensen first.

### TYPICAL AC REGULATORS

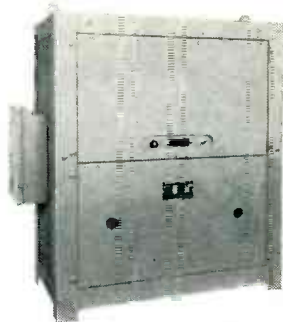

**Model 5000-2S—high power**  
 Input 95 to 130; distortion 3%;  
 load 0-5000 VA;  
 Accuracy  $\pm 0.1\%$  against line  
 or load; 50-60 cycles

**Model 3000S—medium power**  
 Input 95 to 130; distortion 3%;  
 load 0-3000 VA  
 Accuracy  $\pm 0.1\%$  against line  
 or load; 50-60 cycles



**Model 500S—low power**  
 Input 95 to 130; distortion 3%;  
 load 0-500 VA;  
 Accuracy  $\pm 0.1\%$  against line  
 or load; 50-60 cycles

CATALOG A1049 DESCRIBES COMPLETE LINE



**Sorensen and company, inc.**  
 375 FAIRFIELD AVE. • STAMFORD, CONN.  
 MANUFACTURERS OF AC LINE REGULATORS, 60 AND 400 CYCLES; REGULATED DC POWER SOURCES; ELECTRONIC INVERTERS; VOLTAGE REFERENCE STANDARD; CUSTOM BUILT TRANSFORMERS; SATURABLE CORE REACTORS



**CONSOLE TAPE RECORDER SR-950**

The finest studio-type tape recorder available. Operation by push button control. Three motors, three heads. Other features: 30-15,000 cps freq. resp.: Signal to noise ratio more than 52 db at 1½% distortion; Capacity 1 hour at 15"/sec., 2 hours at 7½"/sec. Cabinet designed for quick maintenance.



**PORTABLE RECORDING AMPLIFIER 90-B**

Performance equal to best studio equipment, though portable. Flat response 30-15,000 cps (modified by variable equalizers); three pre-amplifiers, master gain and recording amplifier.

**PORTABLE DISC RECORDER 6-N**

Equipped with Presto 1-D cutting head. Heavy turntable base for reduced vibration — Locking speed shift lever for 78-33½ rpm, rim drive, 17¼" capacity. Ideal for economical broadcast station use.



you name it... **PRESTO** has it!

The variety of PRESTO equipment is one reason engineers all over the nation look to PRESTO for the solution to every recording problem. Pioneer in sound recording, PRESTO excels in the production of precision tape recorders, power, peak limiting and recording amplifiers and flawless recording discs. For the greatest selection of the greatest equipment...PRESTO is a name to remember.



**PRESTO PORTABLE TAPE RECORDER PT-900**

Engineers everywhere are excited about Presto's new portable tape recorder. Packs easily into two portable cases, but sets up into a complete broadcast-quality machine. Three heads...erase, record and reproduce. Separate recording and monitoring amplifiers. Speeds: 15"/sec and 7½"/sec. Illuminated V.U. meter. Three mike input. These important features plus Presto precision workmanship make this the best buy anywhere in portable tape equipment.



**RECORDING CORPORATION**  
Paramus, New Jersey

Mailing Address: Box 500, Hackensack, N. J.

In Canada:  
Walter P. Downs, Ltd.  
Dominion Square Bldg.  
Montreal, Quebec

Overseas:  
M. Simons Company, Inc.  
25 Warren Street  
New York, N. Y.

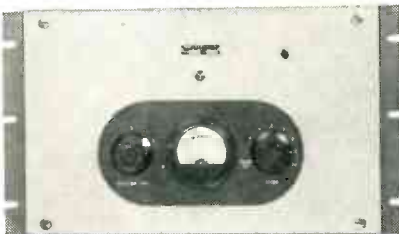

**POWER AMPLIFIER 89-A**

High fidelity, 25-watt power unit for recording or monitoring. All stages push-pull. Designed for vertical rack mounting, circuits completely accessible. Meter and selector switch indicate output level at 1000 cps and tube current readings.

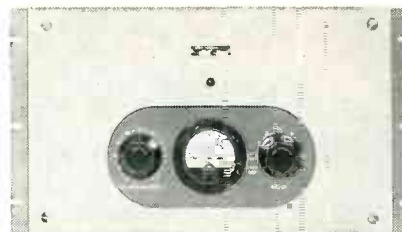

**PEAK LIMITING AMPLIFIER 41-A**

Eliminates overcutting and distortion due to over-modulation. Also acts as line amplifier. 60 db gain compensates for line losses. Allows increase of 3 db program level. Chassis designed for vertical mounting. Meter and selector switch indicate amount of limiting and tube currents.

**TRANSCRIPTION TURNTABLE 64-A**

Operates for long periods of time with no maintenance or adjustments. Direct gear drive at 78 & 33½ rpm, dual motors, Full speed reached within ¼ revolution. Low mechanical disturbance, maximum speed accuracy.





# HARDWICK, HINDLE

PROUDLY ANNOUNCES  
ITS NEW  
NATIONAL  
RESISTORS

Completely Sealed · Completely Satisfactory



- ✓ the core is stronger, and has higher resistance to vibrations and shock.
- ✓ the resistance wire—made to H.H. specifications especially adapted to these resistors—is more uniformly wound so that failures under stress are eliminated.
- ✓ the special alloy terminals are more securely fastened to the ceramic body by spot-welding—highly resistant to corrosion.
- ✓ all wire connections are protected by a positive, non-corrosive bonding.

*and...*

- ✓ *new*—blue-gray enamel coating—crazeless, thermo-shock-proof gives greater protection throughout the most rugged service—longer life under extremes of humidity, salt water and severest atmospheric conditions. And by withstanding higher heat these resistors afford a greater safety factor.
- ✓ The fixed, the ferrule and the flat types are especially designed for and manufactured in accordance with JAN-R-26A specifications.

## HARDWICK, HINDLE, INC.

Rheostats and Resistors

Subsidiary of

THE NATIONAL LOCK WASHER COMPANY

ESTABLISHED 1886

NEWARK 5, N. J.

U.S.A.

the mark



of quality

for more than a quarter of a century

Hardwick, Hindle, Inc.

40 Hermon St., Newark 5, N. J.

Please send additional information about your new resistors.

Name \_\_\_\_\_

Title \_\_\_\_\_

Company \_\_\_\_\_

Address \_\_\_\_\_

# APPLICATIONS UNLIMITED

for the **SO**LA *Constant Voltage* **PRINCIPLE**



**TYPE CVE — PLATE and FILAMENT SUPPLY:** A single, compact source of filament and plate supply voltages . . . regulated to within  $\pm 3\%$  or less with line voltage variations of 100-130 volts. BULLETIN DCVE-138.

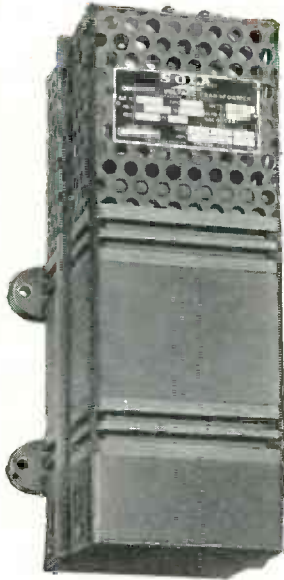

**TYPE CV — STANDARD:** Wide range of capacities and voltages . . . regulation  $\pm 1\%$  or less with a total primary variation of 30% . . . ideal for use with electronic equipment where close voltage regulation is required. BULLETIN DCV-102.

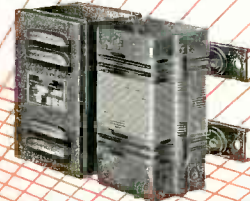

**TYPE CVH — WITH HARMONIC FILTER:** Incorporates harmonic neutralizer circuit . . .  $\pm 1\%$  regulated voltage . . . less than 3% harmonic distortion . . . BULLETIN DCVH-136.

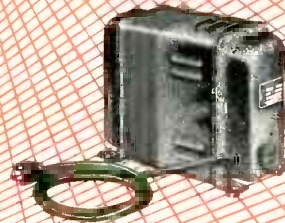

**TYPE CVA — FOR TELEVISION RECEIVERS:** Voltage regulation of home TV Receivers at moderate price . . . plug-in type . . . regulation  $\pm 3\%$  or less . . . BULLETIN DCVA-135.



**BALLASTS — FOR GASEOUS DISCHARGE TUBES:** Maintain a constant level of light output or U. V. radiation over a wide range of line voltage fluctuations . . . BULLETIN DFL-135.

The SOLA Electric Company has consistently set the standards in the voltage regulating field. SOLA built the first Static-Magnetic Regulator which could be economically applied to industrial and commercial equipment. SOLA Transformers have always delivered the highest standard of performance in the voltage regulating industry.

## **SO**LA *Constant Voltage* **TRANSFORMERS**

SOLA Constant Voltage Transformers and Constant Wattage Transformers are manufactured under one or more of the following U. S. Patents: 2,143,745; 2,212,198; 2,346,621.

**Transformers for:** Constant Voltage • Fluorescent Lighting • Cold Cathode Lighting • Airport Lighting • Series Lighting • Luminous Tube Signs • Oil Burner Ignition • X-Ray • Power • Controls • Signal Systems • etc. **SOLA ELECTRIC COMPANY, 4633 W. 16th Street, Chicago 50, Illinois**  
Manufactured under license by: ADVANCE COMPONENTS LTD., Walthamstow, E., England • M. C. B. & VERITABLE ALTER, Courbevoie (Seine), France  
ENDURANCE ELECTRIC CO., Concord West, N. S. W., Australia • UCOA RADIO S.A., Buenos Aires, Argentina



# Jensen

## Model H-510

### COAXIAL 2-WAY SPEAKER

For thrilling life-like reproduction . . . For truly satisfying listening pleasure . . . For a host of history-making features that mean higher performance . . . new flexibility and convenience—be sure to hear and see the Jensen H-510. You'll know why wise listeners tell us it's the best at any price!

\*The Genuine Jensen Wide-Range Series includes a distinguished group of new coaxial and single-unit speakers—a complete range of sizes, ratings and prices. Ask for Data Sheet 152.

*"—best—at any Price!"*



**JENSEN MANUFACTURING COMPANY** DIVISION OF THE MUTER COMPANY  
 6607 South Laramie Avenue, Chicago 38, Illinois • In Canada: Copper Wire Products, Ltd., 351 Carlaw, Toronto

# Akra-Ohm

# PRECISION resistors

## Designed to meet JAN-R-93 specifications

As experienced specialists in precision wire-wound resistors, Shallcross is in close touch with the latest requirements for military uses. Thirteen types listed in Bulletin R3 are designed to meet JAN characteristic "B". Four types are designed to meet JAN characteristic "A".

## PRECISION POWER and FIBER GLASS INSULATED RESISTORS

Practically any Shallcross Akra-Ohm resistor including miniature types can be supplied with fiber glass insulated wire and special impregnation which increases power rating from 2 to 4 times while still assuring high stability and close accuracy. Other precision power types include single layer inductively wound 3- to 10-watt resistors.

## HIGH STABILITY RESISTORS

... Matched pairs or sets

Numerous Shallcross Akra-Ohm resistors can be supplied with guaranteed tolerance to 0.01% and stability to 0.003%. Matched pairs or sets are available to extremely close tolerances.

# SHALLCROSS MANUFACTURING



# by SHALLCROSS

## PRECISION RESISTORS FOR MINIATURIZATION PROGRAMS

Many Shallcross Akra-Ohm types are regularly produced to meet the need for close tolerance and high stability in small resistor sizes. Bulletin R3 contains complete details on standard and hermetically-sealed miniature resistors.

A complete assortment of types, sizes, styles, ranges and mounting facilities for military or industrial uses including electronic measuring and computing equipment.

Keeping fully abreast of modern advancements in precise electronic circuitry, Shallcross Akra-Ohm wire-wound resistors are prime requisites. Many hermetically-sealed and other special types are available. Write for Shallcross Akra-Ohm Engineering Bulletin R3 for complete electrical and mechanical characteristics plus helpful precision resistor selection data.

## PRECISION CARD RESISTORS

Shallcross offers a wide variety of special card-wound resistors to meet practically any specification as to size, type, shape, and protective coating.



**COMPANY** Dept. E-40 **Collingdale, Pennsylvania**

# Now!... a Recording ALPHATRON\* Vacuum Gauge

*for permanent, accurate records of pressures  
from 1 micron to 10mm.*



Answer to a long-felt need, this new recording Alpatron offers you accurate, reliable records in a most important high vacuum range. At will, you can record slow or rapid changes in total pressure between 0 and .1mm. . . between 0 and 1mm. . . and between 0 and 10mm. If desired, the upper scale can be factory-set for 0-20mm. without loss of linearity.

This new instrument is designed to have the versatility and accuracy you want. For additional technical information on the Alpatron principle of operation . . . on other features of this recording combination write today.

#### QUICK FACTS ON THE RECORDING ALPHATRON\*

- Accurate vacuum measurements by alpha particle ionization method.
- Records in three important ranges: 0-.1mm., 0-1mm., 0-10mm. Upper range can be factory-set for 0-20mm.
- Optional control of an external circuit.
- Continuous linear response to total pressure on each range.
- Available with either strip or circular chart recorders.
- Full scale sweeps of 24, 12, 4.5 seconds.
- Gives continuous recordings of either slowly or rapidly changing pressures.
- Available in straight front for panel mounting.

INDUSTRIAL RESEARCH • PROCESS DEVELOPMENT  
HIGH VACUUM ENGINEERING AND EQUIPMENT



METALLURGY • DEHYDRATION • DISTILLATION  
COATING • APPLIED PHYSICS

## National Research Corporation

*Seventy Memorial Drive, Cambridge, Massachusetts*

\*REG. U. S. PAT. OFF.

In the United Kingdom: BRITISH-AMERICAN RESEARCH, LTD., London S. W. 7, England — Glasgow S. W. 2, Scotland



# OHMITE

*High-Current, Rotary*

## TAP SWITCHES

The Most **COMPLETE LINE**  
of its Type on the Market

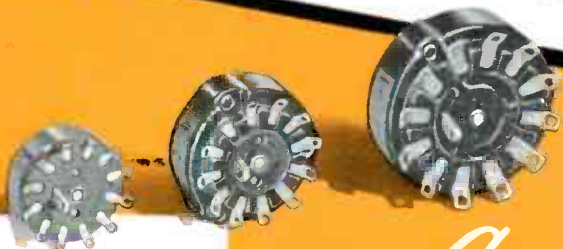
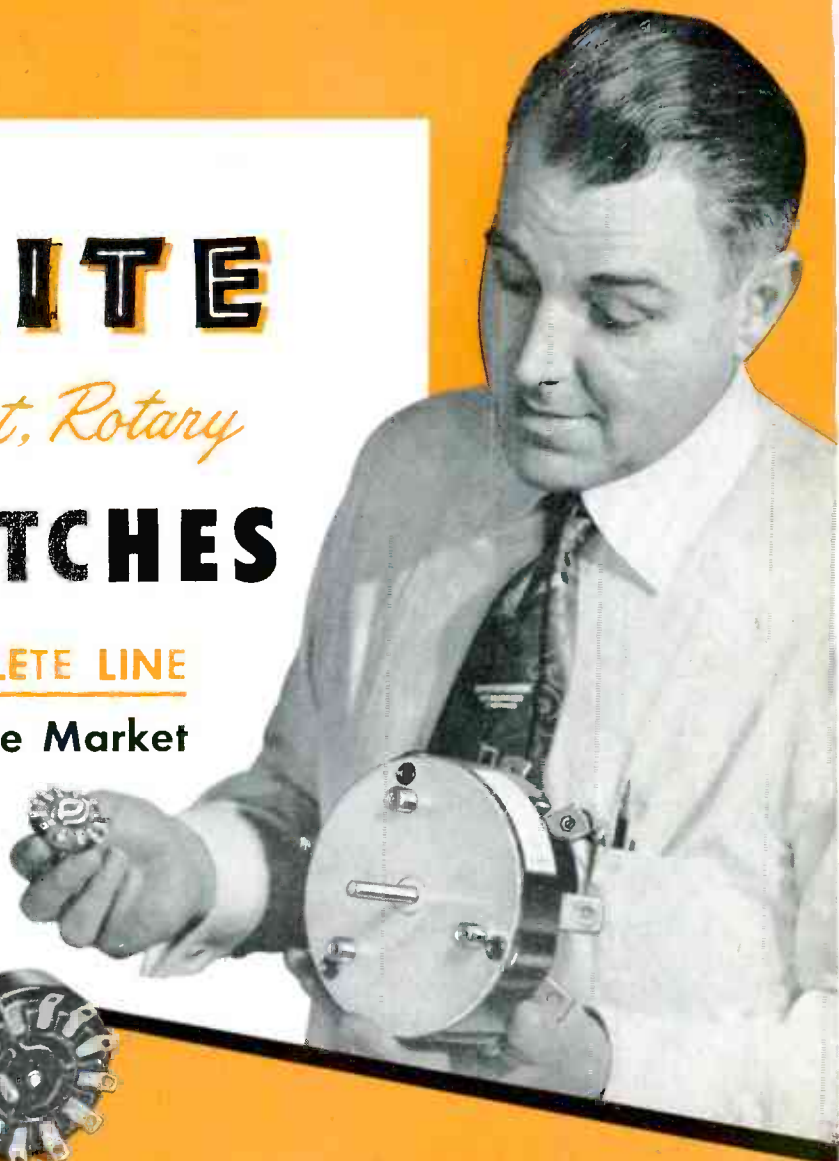

### 5 SIZES

10 amp — 150 v  
15 amp — 150 v  
25 amp — 300\* v  
50 amp — 300\* v  
100 amp — 300 v

\*150 volts between taps

### *Compact-Dependable*

Equipment manufacturers know that when they require high-current, non-shorting rotary tap switches, they can usually find the right type and size in the Ohmite line. Ohmite high-current tap switches are particularly designed for a-c use. Illustrated are five sizes of high-amperage, multi-point selectors. They are extremely compact, providing up to 12 tap terminals. Capacities range from 10 to 100 amperes a-c. In addition to the models shown, Ohmite tap switches are available in open-type models, for both shorting and non-shorting applications. Ohmite is also prepared to supply open type tap switches with special features—such as special angles between taps, and capacities up to 25 contact points. All Ohmite switches can be mounted in tandem for multiple-pole operation.

*Be Right with —*

# OHMITE

Reg. U. S. Pat. Off.

*25th Anniversary*

1925-1950

RHEOSTATS • RESISTORS • TAP SWITCHES

# OHMITE



# High-Current, Rotary TAP SWITCHES

## — PREFERRED THROUGHOUT INDUSTRY

1. **CERAMIC CONSTRUCTION** provides perfect insulation, unaffected by arcing. Contacts and mechanism are entirely enclosed and protected (except for Model 111).
2. **EXTREMELY COMPACT**, yet have many high-current taps, perfectly insulated. Terminals are convenient for wiring. Back-of-panel mounting.
3. **SILVER-TO-SILVER CONTACTS**, for high electrical conductivity. Have low surface resistance, and eliminate contact maintenance.
4. **SELF-CLEANING ROTOR CONTACT**. Slightly rounded, assuring perfect seating and producing slight rubbing motion with every operation.
5. **"SLOW-BREAK" MECHANISM**, incorporating a positive cam-and-roller. Provides "slow-break, quick-make" action, particularly suited to alternating current. Minimizes sparking, extends contact life.
6. **"DEAD" SWITCH SHAFT**. Completely insulated from the load by a high-strength driving hub which will withstand a 2000-volt test.

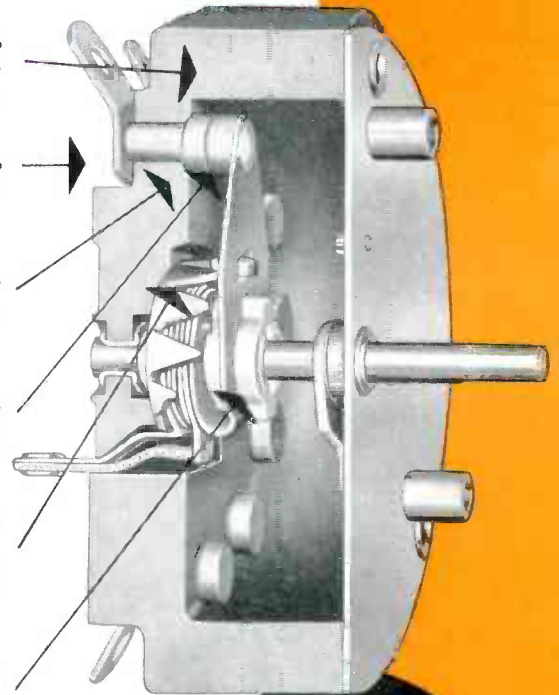

**5 SIZES**

**10 to 100 Amp.**

**A-C**

### AVAILABLE IN TANDEM MOUNTINGS



Have many applications, including simultaneous control of separate circuits. Extended shafts, with universal coupling for single-knob control of two or three switches.

*Write* on Company Letterhead for Catalog and Engineering Manual No. 40.

**OHMITE MFG. CO.**  
4817 Flourney Street  
Chicago 44, Ill.



# OHMITE

Reg. U.S. Pat Off.

## RHEOSTATS • RESISTORS TAP SWITCHES

*25th Anniversary*

1925-1950



**ANOTHER DUMONT FIRST!**

# The New Du Mont-Holmes SUPERSPEED Projector

◆ Sets new standards of performance, utility and economy for TV station operation. Provides a means of film pickup that approaches the contrast and clarity characteristic of studio productions.

◆ **DIRECT FILM PROJECTOR**

Used with a Du Mont Special Image-Orthicon film pickup to give studio clarity to movies and teletranscriptions.

◆ **BACKGROUND PROJECTOR**

Brings dramatic moving sets and backgrounds into any studio. Eliminates costly and cumbersome sets and backdrops.

IMAGE ORTHICON PICKUP HEAD

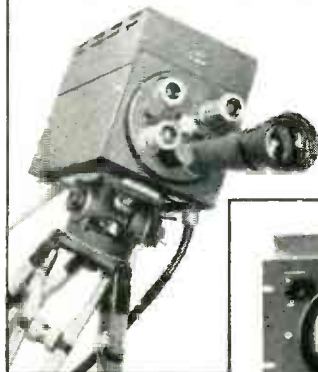

For information on the Superspeed Projector or other Du Mont Telecasting Equipment write, phone, or visit.

ALLEN B. DU MONT  
LABORATORIES, INC.

FLYING SPOT SCANNER

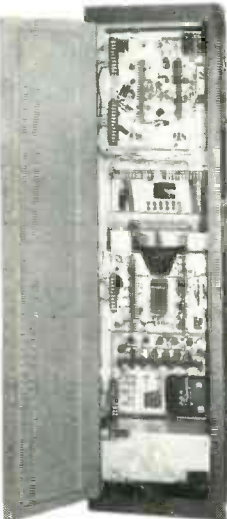

RF WAVEFORM MONITOR



ACORN TRANSMITTER



**DUMONT**

*First with the Finest in Television*

ALLEN B. DU MONT LABORATORIES, INC., TELEVISION TRANSMITTER DIVISION, CLIFTON, N. J.

# Everything IN CARBON but Diamonds!

**PLUS GRAPHITE, MOLDED METALS  
SINTERED ALNICO II**

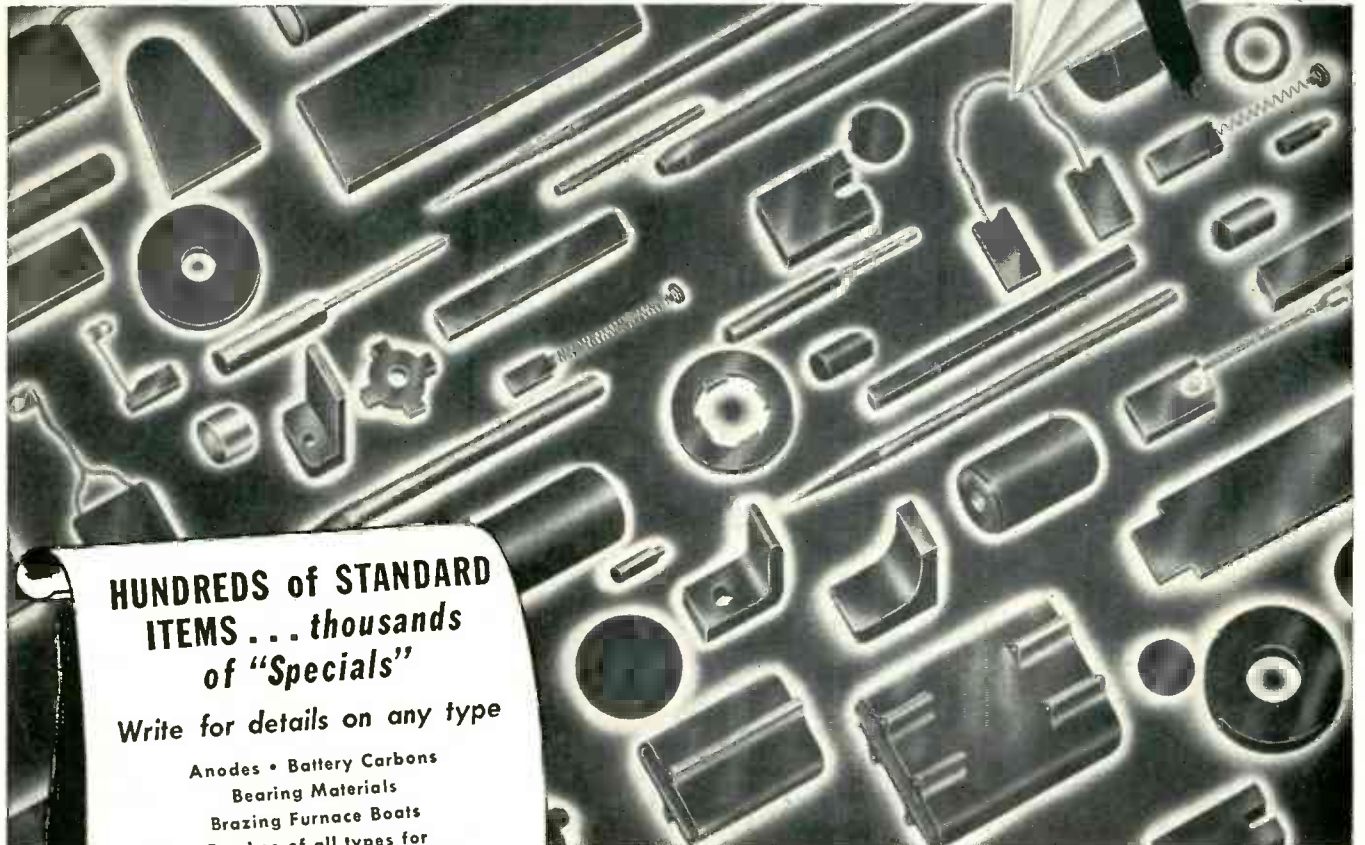

**HUNDREDS of STANDARD  
ITEMS . . . thousands  
of "Specials"**

*Write for details on any type*

Anodes • Battery Carbons  
Bearing Materials  
Brazing Furnace Boats  
Brushes of all types for  
rotating electrical equipment  
Carbon and Graphite Contacts  
Chemical Carbons • Clutch Rings  
Dash Pot Plungers  
Electric Furnace Heating Elements  
Electrolytic Anodes • Friction Segments  
Glass Molds • Ground Rods (carbon)  
Mercury Arc Rectifier Anodes  
Metal-Graphite Contacts  
Power Tube Anodes  
Rail Bonding Molds  
Rare Metal Contacts  
Resistance Welding and Brazing Tips  
Seal Rings (for gas or liquid)  
Special Molds and Dies  
Spectrographite No. 1  
Trolley and Pantograph Shoes  
Voltage Regulator Discs  
Water Heater and  
Pasteurization Electrodes  
Welding Carbons  
Welding Plates and Paste

*. . . a dependable source of supply*

The unique electrical, mechanical, physical and chemical properties of Stackpole carbon, graphite and carbon-graphite products solve countless problems of friction, temperature, arcing, corrosion, shaft sealing, voltage regulating and others. So broad is the line of standard Stackpole products, so extensive the facilities for "specials" that it is practical to list only a few of them here. Let Stackpole engineers recommend and quote on your next requirements.

## **STACKPOLE**

**STACKPOLE CARBON CO., ST MARYS, PA.**



# TWO EVERY WEEK!

*First* OF LOW FREQUENCY  
RADIO TRANSMITTERS  
FOR THE C. A. A.'S  
*Omnirange* SYSTEM

**DESIGNED!  
PRODUCED!  
TESTED!  
SHIPPED!  
ACCEPTED!**

### *Prototype Designed*

and built by Bunnell entirely from C.A.A. requirement specifications

### *Rigid Production Testing*

procedures devised and put in operation by Bunnell development and methods engineers

L. V. P. S. &  
EXCITER

4 KW P. A.



**TYPE TLG OMNIRANGE TRANSMITTER** —  
The transmitter, core of the Omnirange System, consists of L. V. Power Supply and Exciter, 4 KW Power Amplifier, Modulator, 10 KW Power Amplifier, H. V. Power Supply and Control Center, Transformer and accessory equipment.

**J. H. BUNNELL & Co.**

81 Prospect Street, Brooklyn, N.Y., Dept. 115  
Research, Design and Development  
Engineering, Manufacturing

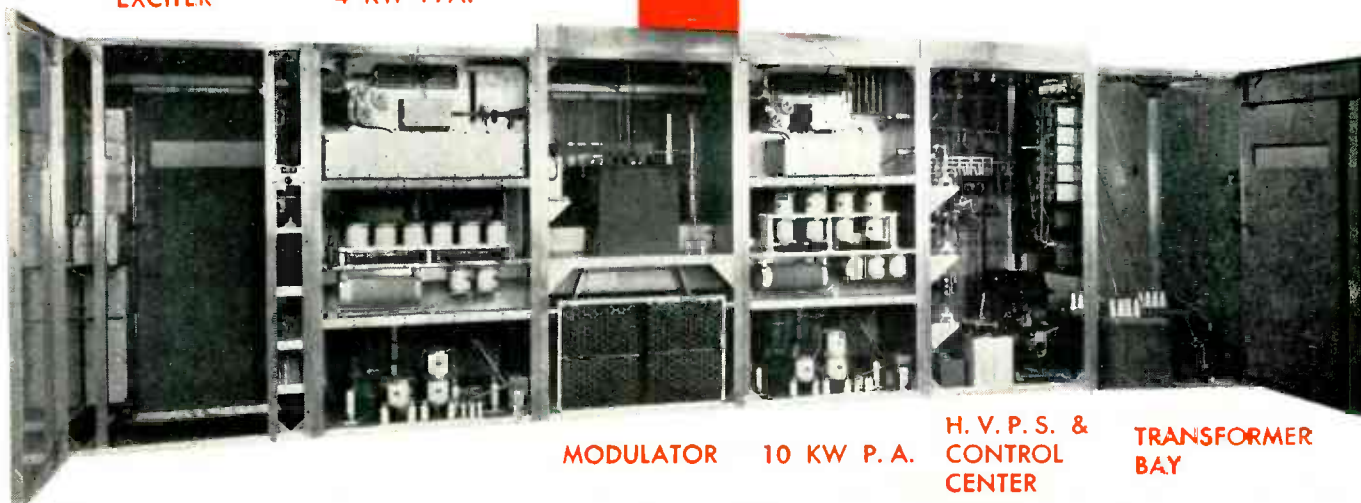

MODULATOR

10 KW P. A.

H. V. P. S. &  
CONTROL  
CENTER

TRANSFORMER  
BAY

# NEW Miniature Telephone Type Relay

## NEW LK RELAY

**MOUNTING:** End mounting for back of panel or under-chassis wiring. Interchangeable with standard "Strowger" type mounting.

**COIL POWER:** From 40 milliwatts to 7 watts D.C.

**CONTACTS:** Standard 2 amperes, special up to 5 amperes. 2 amperes up to 6 P.D.T. 5 ampere contacts (low voltage) up to 4 P.D.T. Special 20 ampere power contacts S.P.S.T., normally open, paralleled.

### DIMENSIONS:

1<sup>5</sup>/<sub>8</sub>" HIGH, 2<sup>7</sup>/<sub>32</sub>" LONG,  
1<sup>3</sup>/<sub>32</sub>" WIDE

*These are the dimensions  
for the 6 pole relay.*

*Will meet Army and Navy  
aircraft specifications  
as a component unit.*

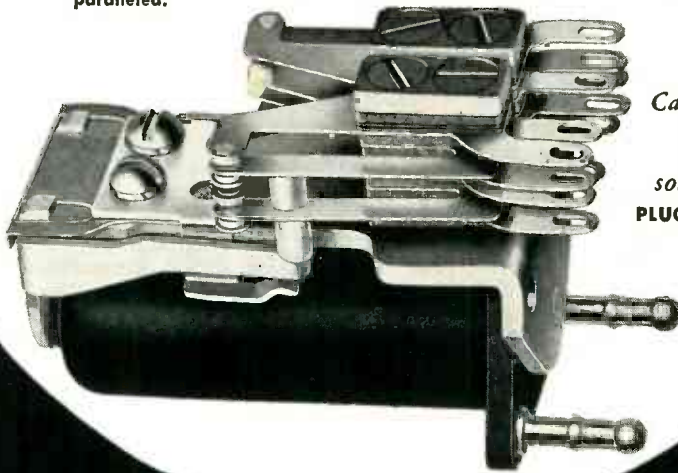

*Can be furnished  
hermetically  
sealed with  
solder terminals.*

**PLUG-IN MOUNTING-SPECIAL.**

## SK RELAY

**MOUNTING:** Front of panel mounting and wiring.

**COIL POWER:** From 100 milliwatts to 4.5 watts D.C.

**CONTACTS:** Same as "LK".

**DIMENSIONS:** 1<sup>1</sup>/<sub>2</sub>" HIGH, 1<sup>1</sup>/<sub>16</sub>" LONG, 3<sup>1</sup>/<sub>32</sub>" WIDE.

*These are the dimensions  
for the 4 pole relay.*

*Will meet Army and Navy  
aircraft specifications  
as a component unit.*

**CAN ALSO BE FURNISHED  
HERMETICALLY SEALED  
WITH SOLDER TERMINALS.  
PLUG-IN—SPECIAL.**

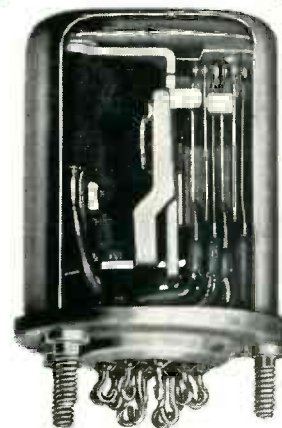

SK, HERMETICALLY SEALED

AL-132



**ALLIED CONTROL CO. INC.** 2 EAST END AVE., NEW YORK 21, N. Y.



# ERIE "GP" CERAMICONS

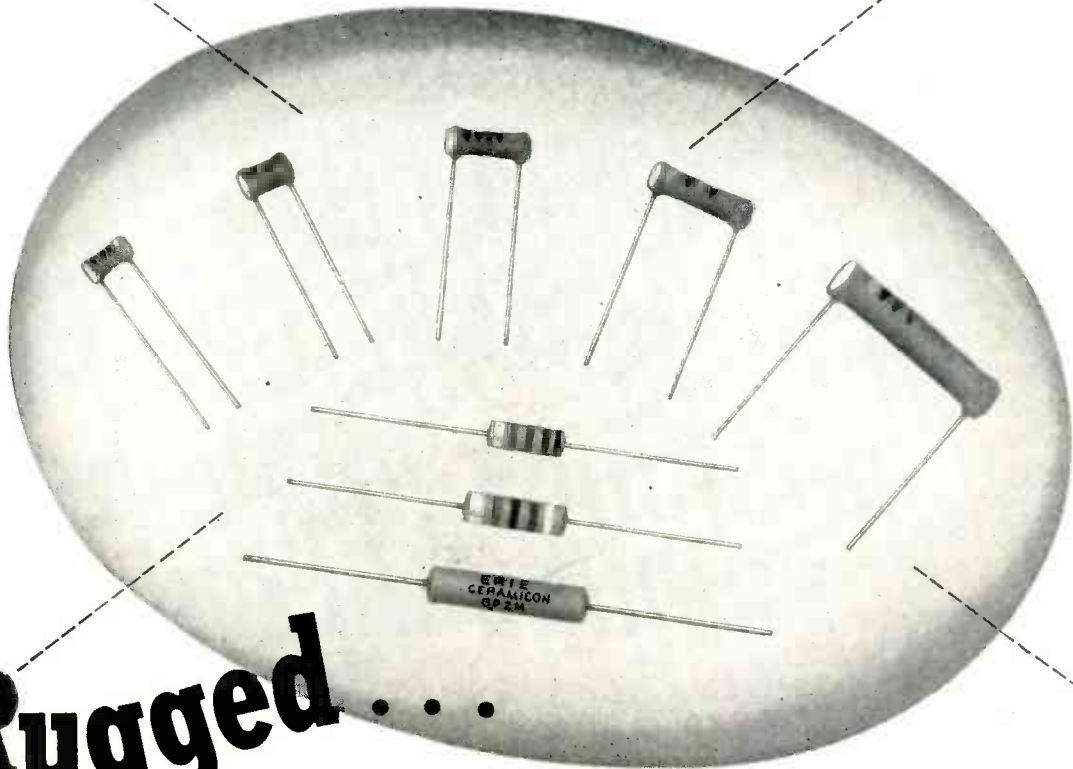

**Rugged . . .**

## DO NOT BREAK IN ASSEMBLY—SERVICE

Erie General Purpose Ceramicons became favorites in the industry when TV sets were still a negligible part of total output. The qualities which recommended them for by-passing and coupling applications which were not frequency determining in radio receiving sets, become even more important in television assembly.

Erie "GP" Ceramicons are rugged and compact. Tubular form and phenolic insulation provide extra sturdiness that withstands rough handling both in installation and in service.

General Purpose Ceramic Condensers are economical because, by limiting them to definite capacity values, they can be manufactured in quantity without sacrifice of quality.

They are made in insulated and non-insulated styles, in popular capacity values up to 10,000 MMF. Write for detailed information and samples.

*Electronics Division*  
**ERIE RESISTOR CORP., ERIE, PA.**  
LONDON, ENGLAND • • TORONTO, CANADA



TV RECEIVER  
MANUFACTURERS—

*New*

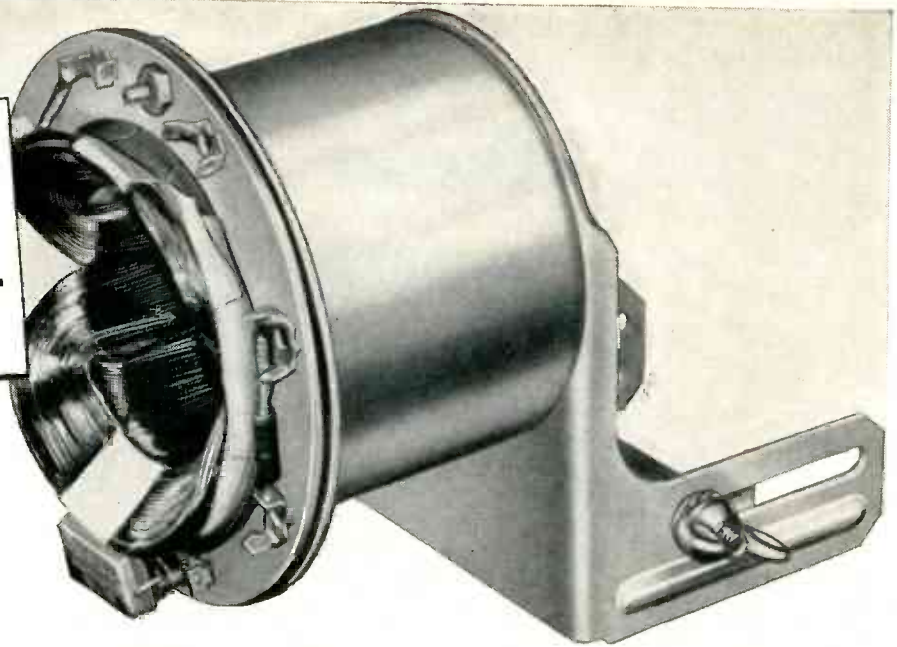

## **DEFLECTION YOKE SWEEPS 70° WITH HIGH EFFICIENCY!**

**Requires only 20 watts of horizontal input power from 260-volt supply!**

A 70° tube is tough to sweep—and to do it correctly takes a lot of power, particularly at 13-14kv. Most yokes today lose efficiency when required to sweep wide-angle tubes.

Now an improved General Electric Deflection Yoke, ready for delivery to manufacturers, licks the problem from the inside out. G-E engineers at Electronics Park found that the key to more sensitivity and greater efficiency was in the design and position of the yoke windings. To get a wire pattern that would assure a

high degree of uniformity of the magnetic field, they designed an improved machine that winds coils with knife-sharp precision and without distortion. This process now helps turn out yokes that provide accurately-shaped, straight-sided pictures.

For applications requiring high efficiency, the new yoke is available with ferrite core. The complete G-E line of television components also includes ion traps, focus coils, horizontal sweep transformers, size and linearity controls. General Electric engineers will be glad to consult with you on the applications of these components to your designs. Wire or write: *General Electric Company, Parts Section, Electronics Park, Syracuse, New York.*

*You can put your confidence in—*

**GENERAL  ELECTRIC**



# cut costs!

Whether your job is large or small, intricate or routine, we take pride in doing the finest job in the entire field of sheet metal housings. And when Karp is called in, your costs are cut down — down!

25 years of know-how go into every "simple" job, as well as into each "complex" project. For the finest of equipment and facilities are all yours, all the time . . . to produce and deliver on time! Karp makes no parts or items of its own, to delay or disrupt your production schedules.

And remember, the facilities of Karp's 70,000 square foot plant belong to you!

Make it a point to call on us for an estimate of your next job. Your inquiries and personal visits are always welcome. An illustrated data book is yours for the asking.



## KARP METAL PRODUCTS CO., INC.

215-63rd Street, Brooklyn 32, New York

*versatile*  
 Multi-channel --  
 telegraph A1 or  
 telephone A3.

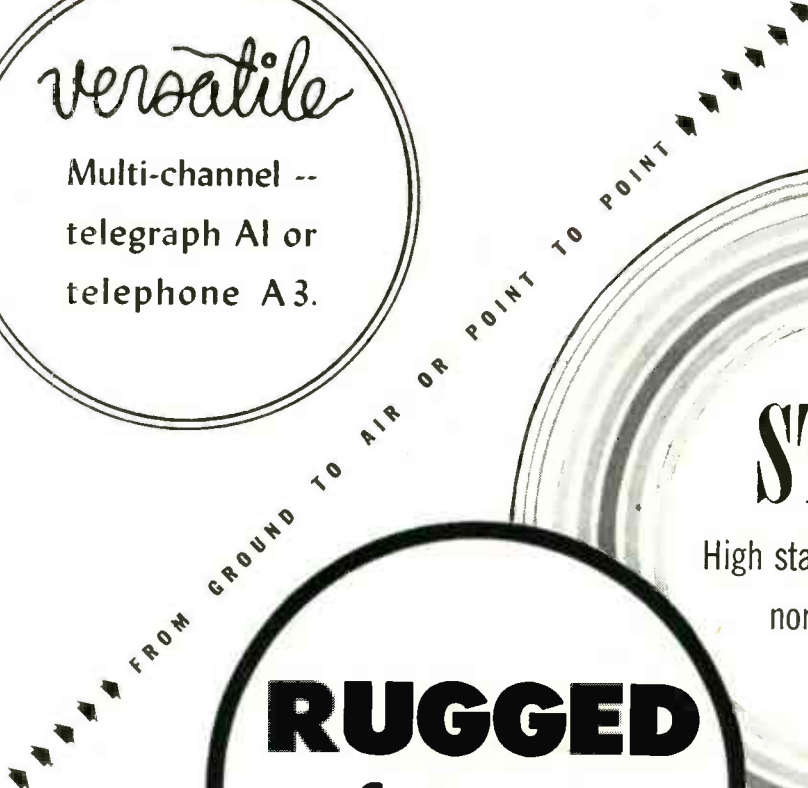

# STABLE

High stability (.003%) under  
 normal operating  
 conditions.

# RUGGED

**Components  
 conservatively  
 rated. Completely  
 tropicalized.**



*Model 446 transmitter operates on 4 crystal-controlled frequencies (plus 2 closely spaced frequencies) in the band 2.5-13.5 Mcs (1.6-2.5 Mcs available). Operates on one frequency at a time; channeling time 2 seconds. Carrier power 350 watts, A1 or A3 AM. Stability .003% using CR-7 (or HC-6U) crystals. Operates in ambient 0° to +45° C using mercury rectifiers; -35° to +45° C using gas filled rectifiers. Power supply, 200-250 volts, 50/60 cycles, single phase. Conservatively rated, sturdily constructed. Complete technical data on request.*

**Here's the ideal general-purpose high-frequency transmitter! Model 446... 4-channel, 6-frequency, medium power, high stability. Suitable for point-to-point or ground-to-air communication. Can be remotely located from operating position. Co-axial fitting to accept frequency shift signals.**

Consultants, designers and manufacturers of standard or special electronic, meteorological and communications equipment.



**AERONAUTICAL COMMUNICATIONS EQUIPMENT, INC.**  
 3090 Douglas Road, Miami 33, Florida

**DEALERS:** Equipeletra Ltda., Caixa Postal 1925, Rio de Janeiro, Brasil ★ Henry Newman Jr., Apartado Aereo 138, Barranquilla, Colombia ★ Radelec, Reconquista 46, Buenos Aires, Argentina



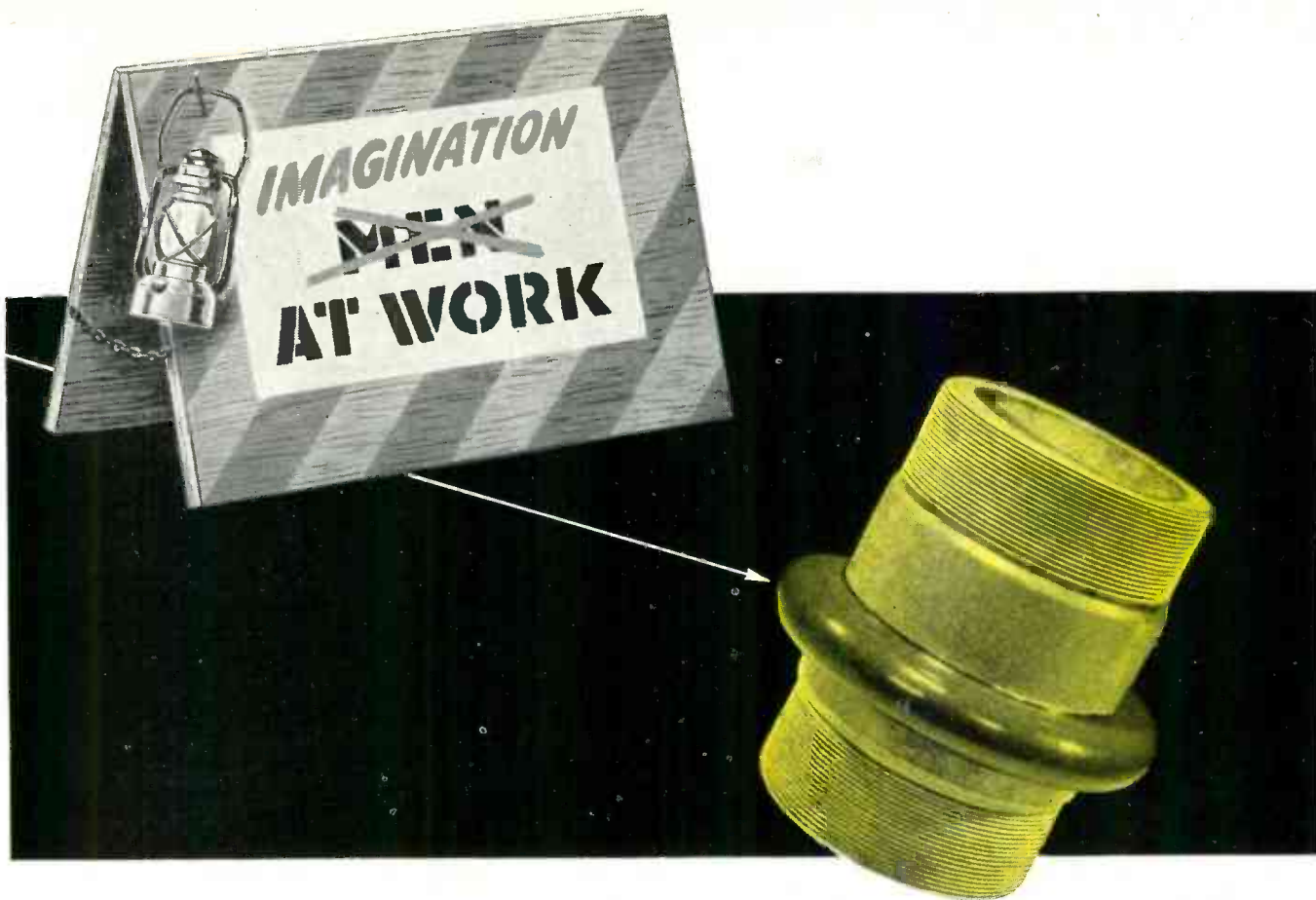

**NO DOUBT** you've experienced it—the real pleasure in grasping a problem, wrestling with it a bit, and then coming up with a solution. The unusual electrical insulation part shown above is a good example. It illustrates the kind of problem that could arise in your plant—and wind up in our "Imagination Department."

To make the part, the Manufacturer wanted plenty of structural strength, dielectric strength, light weight, and resistance to moisture, heat, and corrosion—all wrapped up in a material that was easy to machine. Continental-Diamond studied the problem, used a little imagination, and came up with *two* different plastics—Laminated Dilecto Tubing for the threaded section, and Celoron for the molded, macerated ring.

It's a good example of imagination at work—but it's a better example of how you, too, can depend upon C-D to engineer the right plastic for your needs. For C-D has no "axe to grind." We can recommend from five basic plastics subdivided into a remarkably wide range of grades and combinations of grades to meet your requirements. For complete engineering help or fast delivery of any grade, call your nearest C-D office, any time.

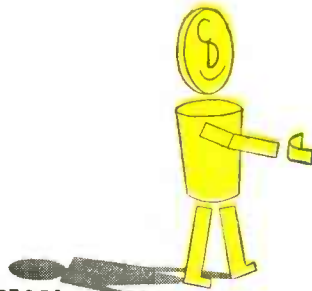

*your partner in producing better products*

- CELORON** (Molded High-Strength Plastic)
- MICABOND** (Bonded Mica Splittings)
- DIAMOND FIBRE** (Vulcanized Fibre)
- VULCOID** (Resin Impregnated Fibre)
- DILECTO** (Laminated Thermosetting Plastic)

DE-2-50

BRANCH OFFICES: NEW YORK 17 • CLEVELAND 14 • CHICAGO 11 • SPARTANBURG, S. C. • SALES OFFICES IN PRINCIPAL CITIES.  
WEST COAST REPRESENTATIVE: MARWOOD LTD., SAN FRANCISCO 3 • IN CANADA: DIAMOND STATE FIBRE CO. OF CANADA, LTD., TORONTO 8

**Continental - Diamond** F I B R E C O M P A N Y

Established 1895. Manufacturers of Laminated Plastics since 1911—NEWARK 16 • DELAWARE

# ATOM SMASHING

## with AEROVOX CAPACITORS

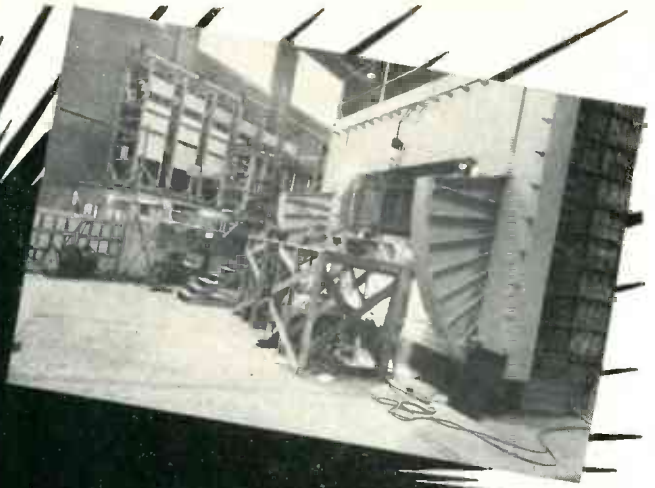

Aerovox Series '26 oil-filled stack-mounting capacitors. One or more units can be conveniently banked in series or parallel. Voltage ratings up to 150,000 D.C. Max. per unit.

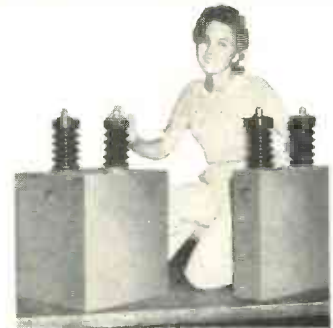

Aerovox Series '20 steel-case oil-filled capacitors. Voltage ratings up to 50,000 D.C.W. Also dual units of 25,000 v. (12,500-12,500) for voltage doubler circuits.

● This Atomic Age calls for huge capacitor banks in atom-smashing installations. Typical is the betatron installation at the University of Illinois, Urbana, Ill., with a capacitor bank totaling 12,960 mfds. made up of 648 units each rated at 20 mfds. 6000 volts D.C. Sufficient energy is stored in this capacitor bank to lift a 3000 lb. car 57 ft.!

Aerovox engineering and experience were important factors in the special design and processing required for the manufacture of these capacitors. Such skill is applied to all Aerovox production, regardless of type or size. Every design is given

*individualized attention.*

Because of outstanding experience with oil-filled capacitors, together with production facilities difficult to duplicate elsewhere, Aerovox is meeting the rigid requirements of atom-smashing installations.

Likewise for other high-voltage needs such as deep-penetration X-ray, radio transmitting, high-voltage testing, carrier-current coupling, and electronic laboratory equipment, Aerovox offers the widest choice of tried-tested-proven capacitors backed by application engineering second to none.

● Try Aerovox first! Our engineers will gladly share their high-voltage capacitance "know-how" with you in solving your particular problem.

## FOR RADIO-ELECTRONIC AND INDUSTRIAL APPLICATIONS

AEROVOX CORPORATION, NEW BEDFORD, MASS., U.S.A.

SALES OFFICES IN ALL PRINCIPAL CITIES • Export: 13 E. 40th St., New York 16, N. Y.

Cable: 'ARLAB' • In Canada: AEROVOX CANADA LTD., HAMILTON, ONT.





**HIGH-ALTITUDE  
TEST CHAMBER**

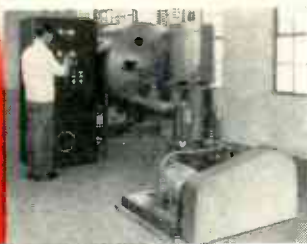

**LAMP and TUBE  
PRODUCTION**



**PENICILLIN  
PRODUCTION**



**COATING  
CONDENSER PAPER**

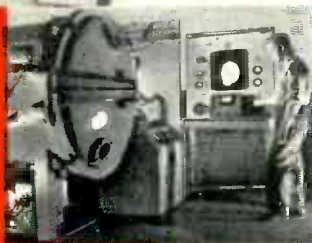

**DEHYDRATING and  
DEGASIFYING OIL**



# KINNEY PUMPS

*belong in your vacuum picture*

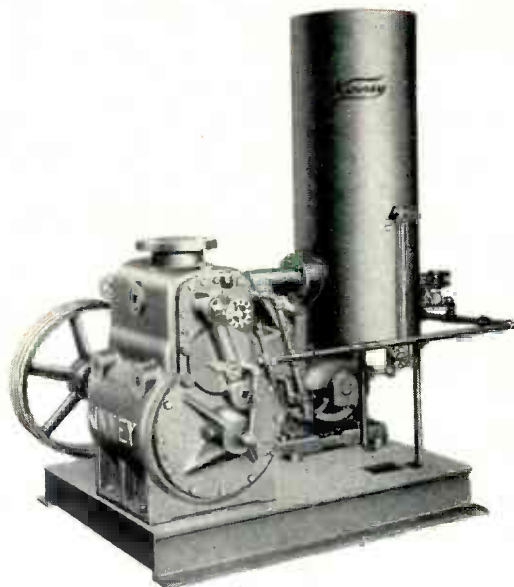

In thousands of successful applications of low pressure processing, Kinney Vacuum Pumps are setting the pace for speed and economy. Fast pump down means fast processing time—and that's why Kinney Pumps are so often picked for the job. In one case they are creating the low absolute pressure required in a gigantic synchro-cyclotron . . . in another, they are helping to turn out a steady stream of peanut-sized electronic tubes. Whether it's "one of a kind" or "mass production", Kinney Pumps have the stamina and rugged dependability to meet the toughest service conditions in every field . . . pharmaceutical or food, metallurgical or optical, electrical or electronic.

Single Stage Models are available in eight sizes: capacities from 13 to 702 cu. ft. per min. — for pressures to 10 microns Hg. abs. Compound Kinney Vac-

uum Pumps are furnished in three sizes — capacities 5, 15, and 46 cu. ft. per min. — for test pressures to 0.5 micron Hg. abs. Send for Bulletin V45 — the complete story on Kinney Vacuum Pumps, Oil Separators, and other Vacuum Pumping Accessories.

**Kinney Manufacturing Company**, 3565 Washington St., Boston 30, Mass. Representatives in New York, Chicago, Cleveland, Houston, New Orleans, Philadelphia, Los Angeles, San Francisco, Seattle.

Foreign Representatives: General Engineering Co. (Radcliffe) Ltd., Station Works, Bury Road, Radcliffe, Lancashire, England . . . Horrocks, Roxburgh Pty., Ltd., Melbourne, C. I. Australia . . . W. S. Thomas & Taylor Pty., Ltd., Johannesburg, Union of South Africa . . . Novelectric, Ltd., Zurich, Switzerland.

*Making old things better  
Making new things possible*

# KINNEY Vacuum Pumps

**LOOK AT IT**

**FOR USE IN LIMITED SPACES**

**...AND YOU'LL PICK THE**

**HONEYWELL** *Mercury Switch*

ACTUAL SIZE PHOTO



The amount of space it occupies is often a mighty important thing to consider when you select a mercury switch.

The "mighty midget," pictured above in actual size, is the tiniest mercury switch in the Honeywell line. It is doing a giant job... affording positive on-off action for as many as 50 million cycles, in such products as coin vending machines, record players and sign flashers.

Honeywell Mercury Switches are compact... are adaptable to unusual mountings. They operate at low angles... have no moving parts... are sealed against dust, gas and corrosion.

The complete line is at your command... affording greater latitude in product design, with improved performance and trouble-free operation. Write for a copy of new Catalog #1343 for down-to-earth information... or call in your local Honeywell engineer for a detailed discussion of a particular application.

MINNEAPOLIS-HONEYWELL REGULATOR CO.  
BROWN INSTRUMENTS DIVISION  
4428 Wayne Avenue, Philadelphia 44, Pa.

Offices in 77 principal cities of the United States, Canada and throughout the world

COMMERCIAL • RESIDENTIAL  
WORLD'S LARGEST  
ORGANIZATION  
FOR ADVANCED  
INSTRUMENTATION  
AND CONTROL  
INDUSTRIAL

FOR  $\left\{ \begin{array}{l} \bullet \text{ POSITIVE ACTION} \\ \bullet \text{ LOW ANGULARITY} \\ \bullet \text{ LONGER LIFE} \\ \bullet \text{ WIDE SELECTION} \end{array} \right\}$  SPECIFY **HONEYWELL**  
*Mercury Switches*

MINNEAPOLIS  
**Honeywell**

*Mercury Switches*

FOR POSITIVE ACTION

**BROWN**  
INSTRUMENTS



# ANNOUNCING

EIMAC TUBE TYPE

# 2C39A\*

PLANAR CONSTRUCTION  
HIGH-MU TRIODE



#### GENERAL CHARACTERISTICS

#### ELECTRICAL

Cathode: Coated Unipotential	
Heater Voltage	6.3 volts
Heater Current	1.0 amperes
Amplification Factor (Average)	100
Direct Interelectrode Capacitances (Average)	
Grid-Plate	1.95 $\mu$ fd.
Grid-Cathode	6.50 $\mu$ fd.
Plate-Cathode	0.035 $\mu$ fd.
Transconductance	
$(i_b = 70 \text{ ma.}, E_b = 600 \text{ v.})$ (Average) 22,000 $\mu$ hos	

#### RADIO FREQUENCY POWER AMPLIFIER

Class-C FM Telephony or Telegraphy  
(key-down conditions, 1 tube)

#### Maximum Ratings

D-C Plate Voltage	1000 Max. Volts
D-C Cathode Current	125 Max. Ma.
D-C Grid Voltage	-150 Max. Volts
Peak Positive R-F Grid Voltage	30 Max. Volts
Peak Negative R-F Grid Voltage	-400 Max. Volts
Plate Dissipation	100 Max. Watts
Grid Dissipation	2 Max. Watts

The new Eimac 2C39A triode is the culmination of over five years of research and application engineering. It is the outgrowth of earlier types 2C38 and 2C39.

Its high performance standards make it the standout triode for VHF and UHF CW service, pulse service and aircraft navigational systems.

As a power amplifier, oscillator, or frequency multiplier, this small high-mu triode exhibits excellent characteristics from low frequencies to above 2500 megacycles.

Let us send you complete data and application notes on the new Eimac 2C39A triode . . . then consider the advantages it offers in the design of compact, moderate power-output equipment.

*\*Conforms with newly issued JAN specifications.*

**EITEL-McCULLOUGH, INC.**  
**San Bruno, California**

Export Agents: Frazer & Hansen, 301 Clay St., San Francisco, California

Follow the Leaders to

**Eimac**  
**TUBES**  
The Power for R-F

**Another Engineering Achievement by Eimac**

# PRECISION FREQUENCIES

**ACCURACY: 1 PART IN 100,000 (OR BETTER) .001%**

The controlling unit of these frequency standards is a bi-metallic fork, temperature-compensated and hermetically sealed against humidity and variations in barometric pressure. When combined with related equipment, accurate speed and time controls are afforded by mechanical, electrical, acoustical or optical means.

Instruments of our manufacture are used extensively by industry and government departments on such precision work as bomb sights and fire control.

Whatever your frequency problems may be, our engineers are ready to cooperate.

*When requesting further details, please specify the Type Numbers on which information is desired.*

## FOR USE IN SUCH FIELDS AS

AVIATION  
ASTRONOMY  
BALLISTICS  
HIGH-SPEED PHOTOGRAPHY  
VISCOSITY MEASUREMENT  
NUCLEAR PHYSICS  
TELEMETERING  
RADIATION COUNTING  
FLUID FLOW  
CHEMICAL REACTION  
NAVIGATION  
SCHOOL LABORATORIES  
INDUSTRIAL RESEARCH LABS.  
ACCURATE SPEED CONTROL

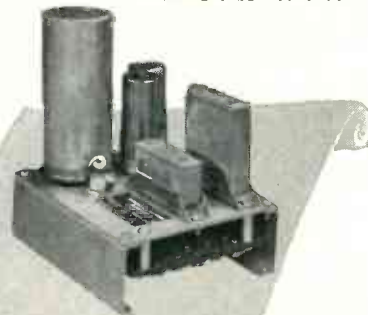

### TYPE 2001-2. BASIC UNIT

Frequencies, 200 to 1500 cycles.  
Dividers and Multipliers available for lower and higher frequencies.  
Miniaturized and JAN construction.  
Output, 6 volts.



### TYPE 2005. UTILITY UNIT

consists of Type 2001-2 and booster to provide 10 watts at 110 V at 60 cyc. Input, 50-100 cyc.



### TYPE 2121A. LAB. STANDARD

Outputs, 60 cycle, 0-110 Volts.  
120-240 cycle impulses.  
Input, 50-400 cycles, 45 W.



### TYPE 2111. POWER UNIT

50 W output. 0-110 V at 60 cyc.  
Input, 50-100 cyc., 275 W.

## American Time Products, Inc.

580 Fifth Avenue

New York 19, N. Y.

OPERATING UNDER PATENTS OF THE WESTERN ELECTRIC COMPANY



# NOW AVAILABLE ON A MASS PRODUCTION BASIS

**CORNELL-DUBILIER**

**TINY  
MIKE®**

**CERAMICS**

— offering the same dependable performance as the specialized C-D Ceramic Capacitors, used for many years by the world's largest manufacturers of instruments and transmitter equipment.

The TINYMIKE now makes it possible for you to get full-sized "Cornell-Dubilier performance" in an ultra-small, space-saving ceramic capacitor only 19/32" in diameter and 5/32" thick.

**Application:** Bypass and coupling in ultra-compact assemblies, especially for TV, FM and VHF.

**Characteristics:** Unusually low inductance, minimized eddy current losses, remarkable electrical ruggedness, high dielectric strength of ceramic, high insulation resistance, low power factor.

TINYMIKES are presently available in 500 volts DC working, with a guaranteed minimum capacity from 1,000 mmfd. to 5,000 mmfd., over a temperature range of + 10° C. to + 65° C. Units available in capacities from 100 to 150 mmfd

can be supplied at a tolerance of  $\pm 10\%$  or  $\pm 20\%$ .

Since the performance of a ceramic capacitor depends in large measure on the quality of its ceramic body, every step in the manufacture of TINYMIKES is controlled by Cornell-Dubilier engineers. This means that the same dependable quality that has made C-D's famous for over 40 years is now available in TINYMIKE ceramics.

Write today for samples and complete technical data. Engineering inquiries solicited. CORNELL-DUBILIER ELECTRIC CORPORATION, Dept. K40, South Plainfield, New Jersey. Other plants in New Bedford, Brookline, and Worcester, Mass.; Providence, R. I.; Indianapolis, Ind., and subsidiary, The Radiart Corp., Cleveland, Ohio.

*C-D Best by Field Test!*



1910-1950

CONSISTENTLY DEPENDABLE  
**CORNELL-DUBILIER**

CAPACITORS — VIBRATORS  
ANTENNAS — ROTATORS — CONVERTERS



Q.

# Why is "dag" Colloidal Graphite best for CRT Exterior Wall Coating?

A.

- It's cheaper
- ... Has better adhesion
- ... Requires no baking
- ... Resists scratching

### BLEEDS STATIC FROM CABINETS TOO!

*Static charges built up in TV sets—particularly where metal CRT's are used—can be successfully bled off by coating the inside of cabinets with "dag" Dispersion #194. This reduces picture interference and also precludes shock. Easy to apply by spraying or brushing.*



"dag" Dispersion #194 is a lacquer-base dispersion of microscopically small graphite particles. It is easily applied to CRT surfaces by spraying, and dries very rapidly, enabling tubes to be handled in 2 or 3 minutes. Maximum adhesion is obtained by drying at room temperature for 24 hours, or by forced infra-red drying for ½ hour.

"dag" Dispersion #194 forms a smooth, uniform, conductive black coating on any type glass. Its adhesive properties are so good that it will resist scratching by a thumb nail or soaking in water.

Prominent CRT manufacturers have found "dag" colloidal graphite dispersions satisfactory and usually cheaper for wall coatings . . . for other electronics work, too. Let Acheson Colloids engineers show YOU how these versatile dispersions can solve many and varied electronics problems. Send the coupon NOW for more information.

ACHESON COLLOIDS CORPORATION  
Port Huron, Michigan

Send me more information on:

- \_\_\_\_\_ "dag" Dispersion # 194 for Exterior Wall Coating
- \_\_\_\_\_ "dag" Colloidal Graphite in Electronics

Name.....

Company Name.....

Address.....

City..... Zone..... State.....

D-5

**ACHESON  
COLLOIDS  
CORPORATION**  
Port Huron,  
Michigan







# INDUSTRIAL TEST EQUIPMENT

## SHOOT TROUBLE *on the line...* REDUCE COSTLY SHUTDOWNS!

**INDUSTRIAL OSCILLOSCOPE**—For tracing circuit trouble in electronic-control equipment, this scope is fast, accurate, and dependable. Ideal for checking welding machines, high wave capacitor discharge panels, variable speed motor controls. Set it down anywhere—the case is insulated . . . carry it easily—weighs only 27 pounds . . . use it in many ways—tests both AC and DC.

- ★ Tests make-and-break of relay circuits
- ★ Checks waveforms in Thyatron control
- ★ Max. input voltage 550
- ★ Sensitivity 0.15 volts dc/inch; 0.18 volts rms/inch.



### IN WELDING OPERATIONS—USE IT TO

- ★ check "hard-starting" ignitrons
- ★ observe voltage shapes on tube elements in timing sequence circuits
- ★ check instantaneous regulation on high current welder supply line
- ★ set "full heat limit adjustment"
- ★ check relays for bounce and high resistance contactors
- ★ check "on" and "off" time in seam welders
- ★ check behavior of peaking transformers
- ★ check high frequency interference switch transients caused by other equipment

**INDUSTRIAL TUBE ANALYZER**—Which tubes are bad? Don't guess—check them quickly, easily with this Analyzer that pays for itself in the cost of tubes you would normally scrap. Tests Thyatrons and Phanatrons with ratings up to 100 amperes peak current. Can be operated by non-technical personnel after brief instruction. Backs up the G-E Industrial Oscilloscope to boost your maintenance efficiency, cut your costs.

\* \* \*

Wherever you are, there's a G-E office nearby. Call there for further information on the equipment you see here. Meanwhile, write us for the Electronic Test Equipment Catalog—it's free! *General Electric Company, Section 440, Electronics Park, Syracuse, New York.*



# GENERAL ELECTRIC





# The Way Up!

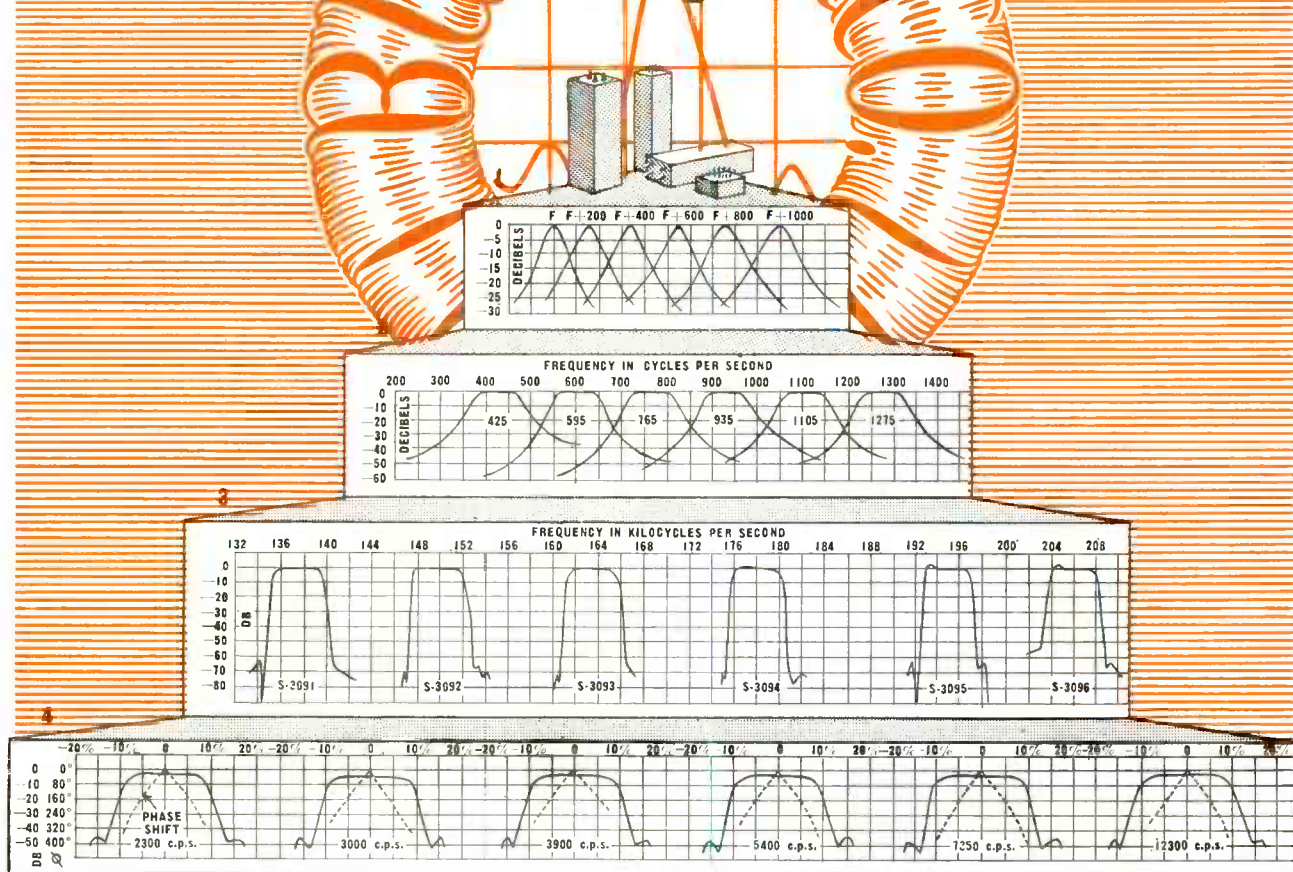

## 1 SUB-MINIATURE "GUIDED MISSILES" FILTERS

For security reasons details of this development in miniaturization must be omitted. It can be told, however, that all six channels are contained in a total volume of 18 cubic inches or 3 cubic inches per channel.

## 2 TONE CHANNEL FILTERS

Available for either 170 or 310 cycles spacing between channels. These filters have received wide acceptance and are extremely popular among manufacturers of carrier telegraph equipment. In addition to the many standard types of tone filters we are supplying, special characteristics can readily be incorporated into designs to suit your application.

## 3 CRYSTAL ELEMENT CHANNEL FILTERS

These extremely sharp wide band filters employing crystals and toroidal coils, were so compact that they were substituted in Air Force equipment for ordinary I.F. transformers. Result was tremendous improvement in selectivity and signal to noise ratio. We derived great satisfaction from this achievement.

## 4 TELEMETERING FILTERS

Among the earliest to be employed in the improved telemetering system now in general use. Particular attention has been paid to linearity of phase shift and good transient suppression as well as high inter-channel attenuation in order to eliminate distortion in telemetering reception.



WRITE FOR TECHNICAL  
INFORMATION

*Burnell & Company*  
YONKERS 2, NEW YORK  
CABLE ADDRESS "BURNELL"

ALL INQUIRIES WILL BE  
PROMPTLY HANDLED

Exclusive Manufacturers of Communications Network Components



# Available Now!

Three types . . .  
one no larger than  
a match box

TYPE

3



TYPE

4

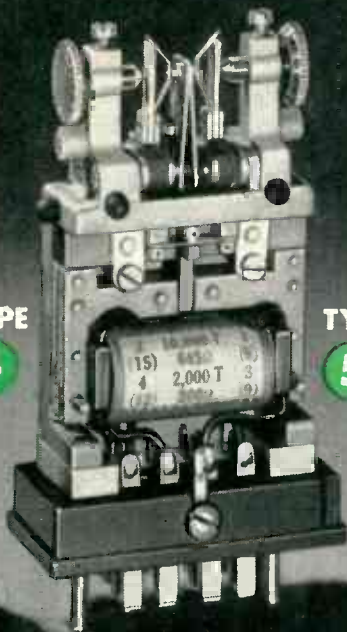

TYPE

5

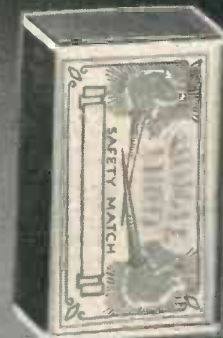
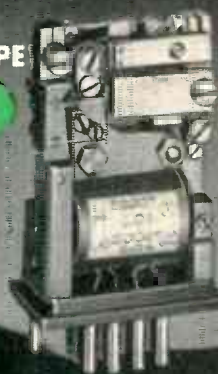

## TYPE 3

Maximum speed, contact pressure, and sensitivity; and minimum transit time. Originally designed as a high-speed telegraph relay, it has also been used for direct operation from barrier-layer photo cells and thermocouples, as well as for measurement and other industrial applications. Weight, 22 oz.

## TYPE 4

Long contact travel, medium speed and sensitivity. Originally designed as a telephone impulsing relay (d-c dialling up to 100 miles, and v-f dialling on trunk circuits), it has also been used in audio-frequency tele-printer systems, etc. Also available in d.p.d.t. version, with self-synchronizing contacts. Weight, 11.8 oz.

## TYPE 5

Miniature relay of phenomenal performance in proportion to size and weight. Primarily developed for military and aircraft uses, but is providing answers to problems in many other fields. Rugged design of exceptional thermo stability. Dimensions of relay proper same as safety-match box. Weight, 4.8 oz.

# CLARE RELAYS



# ..A POLARIZED RELAY

## Far in Advance of the Field!

### C. P. CLARE & CO., secures U. S. rights to bring you the English-made CARPENTER POLARIZED RELAY

In recognition of a widespread need for a polarized relay capable of repeating with high accuracy feeble signal pulses of varying time duration and of maintaining this ability for long periods without attention, C. P. CLARE & CO. set out to design such a relay, to have the following characteristics:

- High sensitivity
- Low hysteresis
- Short transit time
- Complete absence of contact rebound
- Ease of adjustment
- Long operational life between adjustments
- High contact pressure
- Absence of pivots, with their almost inevitable shake and liability to wear or bind
- Immunity from the effects of mechanical vibration
- Absence of positional error
- Immunity from the effects of external fields
- Shortness of operating time — important for some applications.

A comprehensive survey of available relays, made as a prelude to this design project, disclosed that the CARPENTER POLARIZED RELAY, manufactured by Telephone Manufacturing Co. Ltd., of London, England, conforms closely to the ideal and surpasses all previously existing polarized relays.

That this superior relay might be made immediately available to its customers, C. P. CLARE & CO. have paid a high compliment to another relay manufacturer: they have arranged to be exclusive distributor of the CARPENTER POLARIZED RELAY in the United States.

Some of the remarkable features of the CARPENTER POLARIZED RELAY which make C. P. CLARE & CO. proud to sponsor it are described on these pages. More complete information is immediately available from CLARE sales engineers located in principal cities. Look in your classified telephone directory . . . or write: C. P. CLARE & CO., 4719 West Sunnyside Avenue, Chicago 30, Ill.

Write for CLARE Bulletins 110-111-112 for complete details

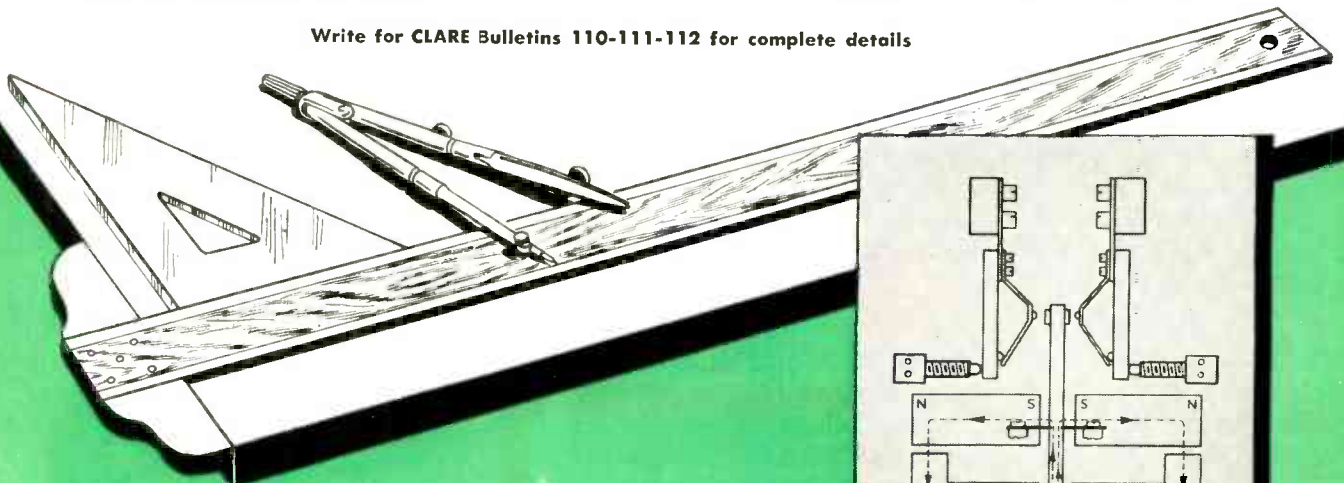

#### MAGNETIC CIRCUIT OF TYPE 5 RELAY

This schematic diagram shows the magnetic circuit of the Carpenter Type 5 Relay in one plane. Actually the axis of vibration of the armature is parallel to the axis of the signal coil. The working pole pieces (the S poles) of the permanent magnets and the contact mounts overlap one another on either side of the armature. The reversal circuit is reduced to its simplest possible form, having only a single air gap in which the armature is situated.

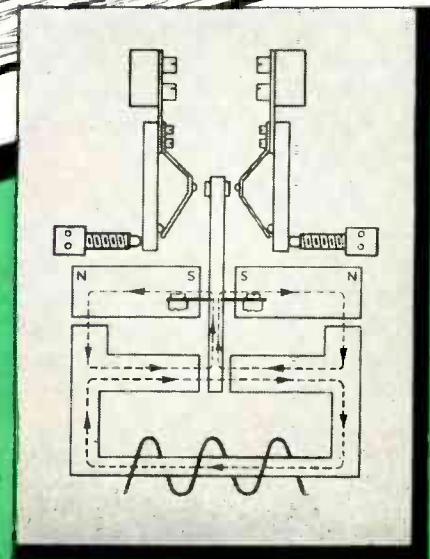

# ..First in the Industrial Field

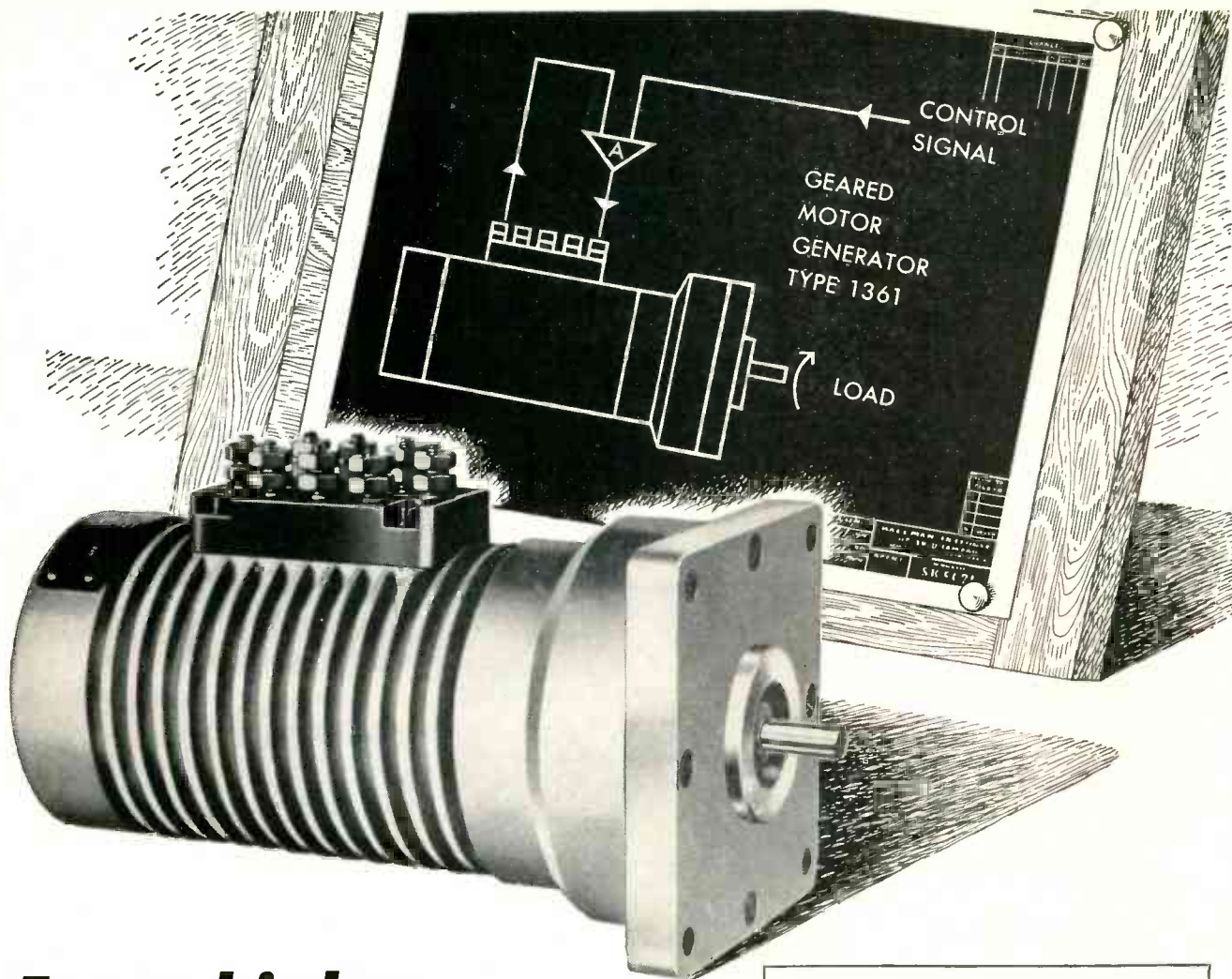

## For a higher order of PRECISION in control

The characteristics of Kollsman miniature Motor-Driven Induction Generators suggest many remote indication and control applications. These light, space-saving units—precision-engineered for extreme sensitivity—combine motors of high torque/inertia ratio with generators offering *linear voltage vs. speed* ratios over a wide range.

These Motor-Driven Induction Generators are representative of a complete line of small Kollsman special-purpose AC motors. If those available do not meet the requirements of your particular instrumentation or control problem, Kollsman laboratories are staffed and equipped to develop a unit to your specifications. For further information, write: Kollsman Instrument Division, Square D Company, 80-64 45th Avenue, Elmhurst, N. Y.

### Kollsman Motor-Driven Induction Generators

**Motor characteristics:** Maximum torque at stall—smooth-running (will not “cog”), fast-reversing—operate from 2-phase source, or from single-phase source with phase-shifting condenser.

**Generator characteristics:** Low residual voltage—output/residual voltage ratio of 100:1 in some models—residual voltage “spread” as low as 2 millivolts—available with built-in voltage temperature compensating network—constant frequency output—amplitude directly proportional to speed.

**Unit characteristics:** Both rotors mounted on same shaft, assuring positive alignment—geared models, with ratios between 5:1 and 75,000:1, designed to safely transmit a maximum torque of 25 oz./in.—backlash held to a minimum.

**KOLLSMAN INSTRUMENT DIVISION**

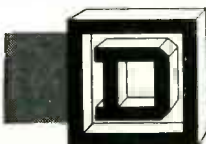

**SQUARE D COMPANY**

ELMHURST, NEW YORK

GLENDALE, CALIFORNIA



# ELECTRONIC EQUIPMENT MANUFACTURERS—

## GENERAL ELECTRIC

*Welded*

## GERMANIUM DIODES

- ...save space
- ...reduce heat
- ...eliminate feedback



**"BEFORE YOU DESIGN,  
LET US HELP YOU WORK OUT  
A BETTER WAY!"**

### APPLICATION ENGINEERING SERVICE

A corps of G-E engineers, specialists in tube and diode applications, are available to help you with your circuit problems. Strategically situated in major cities, these men are at your service whenever you need them. Inquire at the G-E office nearest you, or write: *General Electric Company, Electronics Park, Syracuse, New York.*

### IF YOU MAKE—

- TV Receivers
- AM-FM Receivers
- AM-FM-TV Transmitters
- Studio Equipment
- Computers
- Measuring Equipment
- Electronic Controls
- UHF Equipment
- Counters
- Radar
- Communication Relays
- Carrier Current Equipment
- Nucleonics Devices

GENERAL  ELECTRIC

SEND FOR THE NEW, COMPLETE G-E GERMANIUM DIODE HANDBOOK—packed with useful information for the electronics engineer and designer!

General Electric Company, Section 440  
Electronics Park, Syracuse, New York

Please send me \_\_\_\_\_ copies of the new G-E Germanium Diode Handbook at \$1.25 per copy postpaid.

Bill me       Check or M.O. enclosed

NAME \_\_\_\_\_

ADDRESS \_\_\_\_\_

CITY \_\_\_\_\_ STATE \_\_\_\_\_

# RMC DISCAPS

Exceed Guaranteed Minimum  
Capacity at 85°C

Capacity change between room  
temperature and 65°C, +18% - 0%

More than eight years of intensive engineering research and three years of successful commercial production are behind this outstanding RMC achievement.

Type B Series DISCAPS were developed to maintain capacity much nearer initial values than heretofore possible. This accomplishment, in small size condensers that have real practicability, results in a decidedly more effective by-pass at the higher frequencies encountered in TV and FM applications. Because RMC produces the complete condenser, even to the processing of the dielectric element itself, it is possible to exercise the finest quality control through every phase of manufacturing.

## The Newest Development in Ceramic By-Pass Condensers

Type B Series DISCAPS are the smallest disc ceramics available. 1000 mmf. and 1500 mmf. DISCAPS are actually less than one-half the size of competitive condensers.

Improved processes of dielectric element impregnation and outer casing insulation are exclusive with DISCAPS. Their low self inductance, low power factor and moisture impervious characteristics place them in a class alone. Approval by leading makers of TV sets and tuners as well as manufacturers of specialized high frequency equipment is proof of their superiority.

SEND FOR SAMPLES AND TECHNICAL DATA

### RMC DISCAP TYPE B BY-PASS SERIES

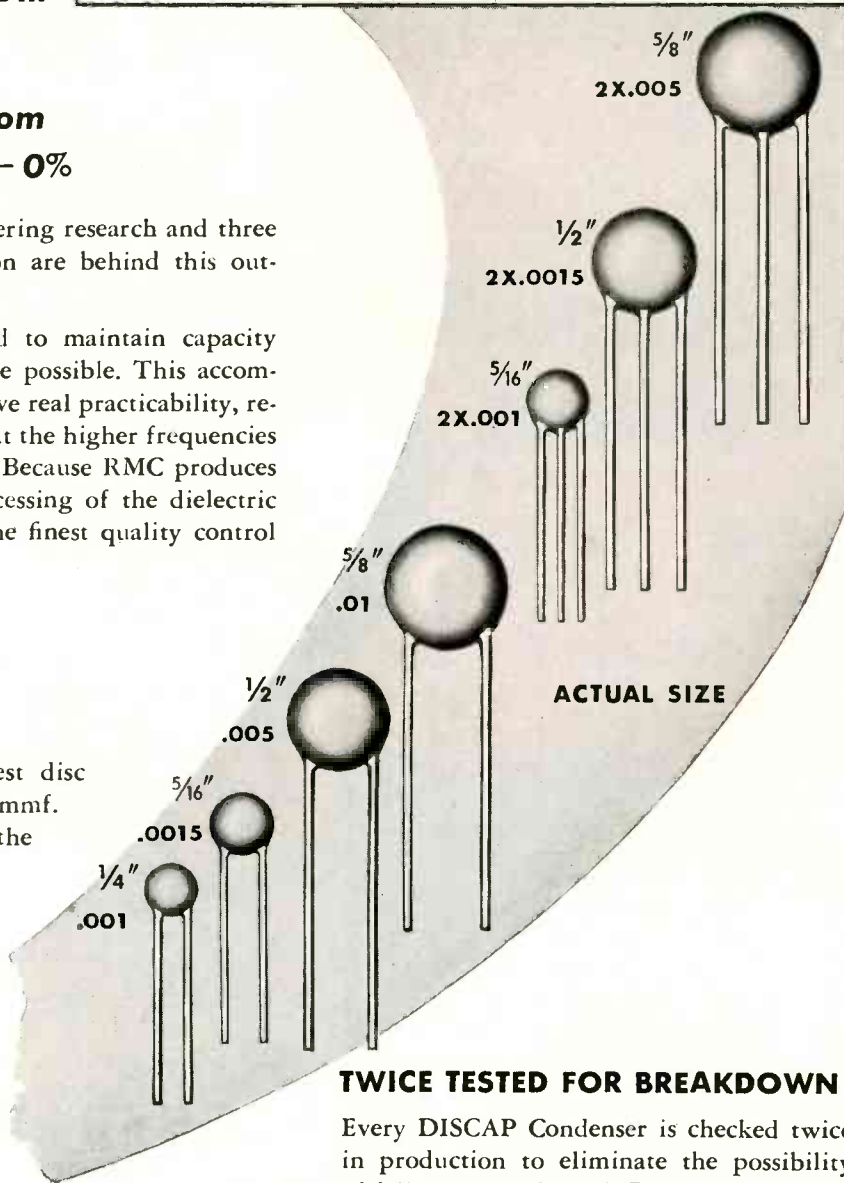
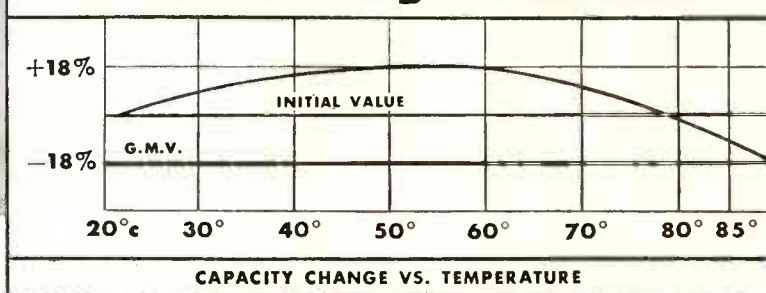

### TWICE TESTED FOR BREAKDOWN!

Every DISCAP Condenser is checked twice in production to eliminate the possibility of failure in service. All DISCAPS are rated at 600 V.D.C. and tested at 1200 V.D.C. Yes, DISCAPS are definitely better...they will save you money, too!

DISCAP  
CERAMIC  
CONDENSERS

# RMC

**RADIO MATERIALS CORPORATION**

GENERAL OFFICE: 1708 Belmont Ave., Chicago 13, Ill.

FACTORIES AT CHICAGO, ILL., AND ATTICA, IND.



**ZERO TO  
500 VOLTS  
AT  
200 MA**



**New *hp* Model 712A  
HIGH REGULATION POWER SUPPLY \$250**

f. o. b. factory

**SPECIFICATIONS**

**OUTPUT VOLTAGES:**

- DC. *High voltage.* 0-500 volts (without switching) 200 ma. maximum load.
- DC. *Bias voltage.* 0-150 volts, 5 ma. maximum load.
- AC. *Unregulated.* 6.3 volts at 10 amps maximum load.

**REGULATION:**

- H.V. Better than 1/2% from no load to full load, 20 to 500 volts; or for line voltage, 105 to 125 volts.
- Bias. Better than 1% from no load to full load at maximum output voltage. Regulation at any other voltage depends on setting of voltage control. Internal impedance may be as high as 25,000 ohms.

**METERS:**

- Current Meter.* 0-200 ma. (High voltage only.)
- Voltmeter.* 2 ranges — 0-500 and 0-150 volts. Meter range may be switched to facilitate reading of high voltage output. 0-150 volt range may be switched to read bias output voltage.

**HUM:** Less than 8 mv.

**TERMINALS:**

Either positive or negative high voltage terminal may be grounded. Positive terminal of bias supply is permanently connected to negative high voltage terminal.

**INPUT POWER:**

Approximately 400 watts maximum at 105-125 volts, 50/60 cycles.

**OVERLOAD PROTECTION:**

Load and line separately fused. Fuses available on front panel.

**MOUNTING:**

Relay Rack Panel. Finish, -hp- grey. Detachable end pieces with hinged handles for table use, \$5.00 per pair.

**SIZE:** 10 1/2" x 19", 13" deep. Weight 60 lbs. Shipping weight 85 lbs.

**PRICE:** \$250.00 f.o.b. Palo Alto, California.

*Data Subject to Change Without Notice.*

▶ **Continuously variable plate and bias voltages.**

▶ **High stability, 1/2% regulation.**

For laboratory, production work or industrial use, the new *hp*- Model 712A is one of the most economical, convenient and broadly useful power supplies you can buy. It provides continuously variable regulated plate and bias direct current, as well as a 10 ampere, 6.3 volt alternating current for filament supply. It is a particularly useful power source for small transmitters, constant frequency oscillators, temporary set-ups or "breadboard" layouts. In nearly every application,

▶ **General purpose ac filament voltage.**

▶ **Separate voltage and current meters.**

the instrument's ease of operation and ability to meet many different power requirements saves valuable engineering time.

**CONSERVATIVE RATING**

The design of *hp*- Model 712A is such that tubes operate well below manufacturer's rating, even under conditions of low output voltage and high current. Transformers are conservatively rated and only oil-filled condensers are employed to insure long, trouble-free service even under extreme operating conditions.

*For details and demonstration, see your local Hewlett-Packard representative or write direct to the factory.*

**HEWLETT-PACKARD COMPANY**

2057A Page Mill Road • Palo Alto, California

**Export:** FRAZAR & HANSEN, Ltd., 301 Clay Street, San Francisco, Calif., U. S. A. **Offices:** New York, N.Y. and Los Angeles, California

2057

***hp* laboratory instruments**  
FOR SPEED AND ACCURACY

**Attenuators**  
Electronic Tachometers  
Microwave Power Meters  
Tunable Bolometer Mounts  
Slotted Lines  
Standing Wave Indicators  
Low Pass Filters

**-hp- PRODUCTS:**  
VHF and UHF Signal Generators  
Voltage Dividers, Multipliers and Shunts  
Electronic Frequency Meters  
FM and TV Broadcast Monitors  
Regulated Power Supplies  
Audio Frequency Oscillators

Audio Signal Generators  
Vacuum Tube Voltmeters  
Frequency Standards  
Square Wave Generators  
Wave Analyzers  
Distortion Analyzers  
Amplifiers

YOU CAN BE **SURE**.. IF IT'S  
**Westinghouse**

ACTUAL  
SIZE

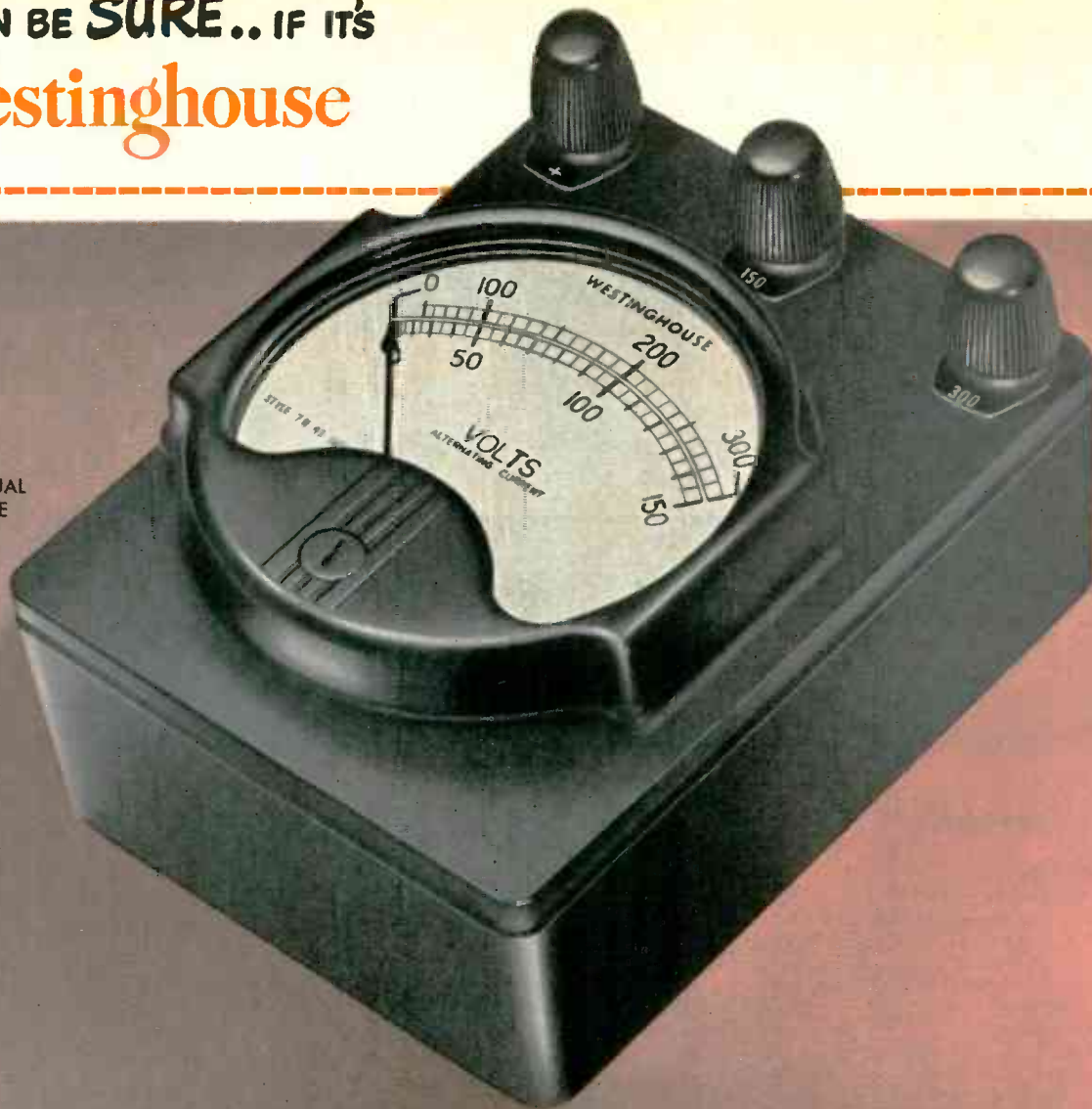

**THIS NEW PORTABLE IS ONLY ONE EXAMPLE  
OF HOW YOU CAN MEET ALL ELECTRICAL  
MEASURING REQUIREMENTS... PORTABLE...  
SWITCHBOARD... PANEL.**

**Here's Why...**

- ★ **The most complete line**  
in the industry! Supply your instrument needs from one source.
- ★ **Shipments in 10 days!**  
We can meet practically every electrical measuring requirement 10 days from receipt of order at the factory.
- ★ **Meets A S A standards!**  
The most exacting specifications for instrument manufacture ever devised.



---

# The First

# LOW-COST PORTABLE

# of its kind!

★ **Magnetically shielded...**

may be used anywhere—guarded against errors due to proximity of other instruments, high current busses, magnetic fields or magnetic materials.

★ **Convenient pocket-size...**

small and compact—without sacrifice of performance—completely insulated for safe use.

★ **Complete variety of ratings...**

in a-c, d-c and rectifier types for the full range of current and voltage measurements.

Westinghouse has this great, new, portable instrument line ready for you now . . . the first instruments in the low-priced field that are specifically designed and manufactured to provide *all* of these features. Phone, write or wire your nearest Westinghouse representative. He will have an experienced instrument specialist help you plan your needs, whether they be portable, panel or switchboard instruments. Write for C.S. 43-100. Westinghouse Electric Corporation, 95 Orange Street, Newark, New Jersey.

J-40389

*Specify Westinghouse - get more for your instrument dollar!*

---

**Westinghouse**  
**INSTRUMENTS**



the New  
**PYRAMID**  
"Humidi-Seal"

(TUBULAR PAPER CAPACITOR)

**Repels Moisture!**

Ruggedly built to withstand undue vibration and rough handling

Outer tube plastic impregnated to prevent moisture-absorption

Light outer coat of high-temp wax provides double protection

Each end plastic sealed against moisture

Leads anchored securely in solid plastic end

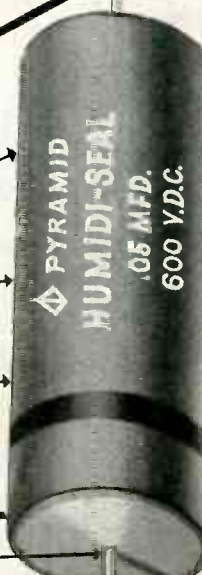

Type 85TOC "Humidi-Seal" capacitors are specially designed for 85° C. operation, even in the most humid atmospheres, and will meet the severe present-day demands of endurance in television receivers, auto radios, etc.

WRITE FOR COMPLETE LITERATURE

Representatives and Distributors throughout the U.S.A. and Canada



**PYRAMID**

**PYRAMID ELECTRIC COMPANY**

155 Oxford Street  
Paterson, N. J., U.S.A.

TELEGRAMS: WUX Paterson, N. J.  
CABLE ADDRESS: Pyramidusa

# BUSINESS BRIEFS

By W. W. MacDONALD

Californians are always optimistic about the future of their State, and apparently it does not take long for a newcomer to acquire the habit.

Cledo Brunetti, who until recently was with the National Bureau of Standards but is now with Stanford Research Institute, said in a recent speech that because western industry does not have to worry too much about amortizing investments made long ago it is likely to adopt automatic control equipment more rapidly than industry in other sections of the country.

He also said that the west is just beginning to realize its electronics production potential, and that it will not be long before it will be manufacturing most of its own component parts.

Receiving-Type Tube failures accounted for 38.5 percent of the unscheduled equipment removals by Piedmont Airlines in 1949. Supervisor of Radio Maintenance W. D. Rollick sees some hope of improvement, however, as the type 5654 tube appears to have a figure of merit of 1,200 compared to the 50-hour life expectancy of the original commercial 6AK5 after which it was modelled.

Large Tubes of the transmitting and industrial type have had their lives extended quite materially, particularly since the war. We saw one the other day that has been upgraded by the manufacturer from 1,000 to 7,000 hours in the last five years.

Speaking Of Industrial Tubes, the trend seems to be toward metal and ceramics. There are three reasons: (1) better heat dissipation, (2) lower costs and (3) more rugged appearance.

The Amateur Market has been a disappointment to many component-part manufacturers so far this year. Possible explanations include tv, the continued availability of surplus gear and a grow-

ing tendency to buy manufactured equipment rather than to build.

Any other reasons occur to you?

Radio-Phono-Tele Production in 1949 by RMA members was as follows:

	TYPE	%	Number
Electric			
Table (under \$12.50 billing price)		10.09	1,025,488
Table (over \$12.50 billing price)			
A-M		15.77	1,601,814
A-M/F-M		4.53	459,883
F-M (including converters)		.31	31,840
Consoles		.04	4,286
A-M		.13	13,271
A-M/F-M			
Table-Radio-Phonos			
A-M		1.51	153,118
AM/F-M		.01	1,241
Console-Radio-Phonos			
A-M		.83	84,722
A-M/F-M		3.63	369,270
Battery			
Portable A-C/D-C		11.57	1,175,056
Table		.54	55,003
Consoles			
Auto		22.56	2,291,884
Television			
Table Models			
Without Radio		14.20	1,442,494
Table Models			
With Radio			
Console or Consolette			
Without Radio		7.84	795,982
Console or Consolette			
With Radio			
Radio-Phonos		1.73	175,421
Phonographs			
Phono only		1.79	181,351
With radio attachment		2.92	296,967
TOTAL		100.00	10,159,091

Production of radios, phonographs and television sets by months was:

January	8.22%
February	7.09
March	8.88
April	7.19
May	6.86
June	6.90
July	4.31
August	8.05
September	7.96
October	10.23
November	13.53
December	10.18

Popocatepetl Crash of a Mexican airliner last September kicked up sufficient fuss in the country to cause its Congress to recommend immediate modernization of navigation equipment and systems. Funds for the job will probably be voted at the present session, and much of the money will go for electronic apparatus.

An Enterprising Manufacturer in Red Bank, N. J. is offering electronic engineers cravats that are "symbolic yet conservative." You can buy an "electron-tube tie" or a "radio-circuit tie" in blue and red, brown and gold, red and gray,





*New!*

## 20 PIN PLUG-IN HERMETIC TERMINAL

TERMINAL ILLUSTRATED  
IS #232OHTO



The advantages of the octal type key plug-in terminal are now extended to include applications calling for as high as 20 pins. Many additional types of relays and other electrical components may now employ this simple fool-proof combination of hermetic sealing and plug-in connection. Sockets are available.

All Fusite Hermetic Terminals are an interfusion of steel and inorganic glass. Write Dept. E for specifications and complete information.

# THE FUSITE CORPORATION

CARTHAGE AT HANNAFORD, NORWOOD, CINCINNATI 12, OHIO

# SHOCK AND VIBRATION NEWS

BUSINESS BRIEFS

(continued)



## NEW AIRCRAFT RADIO SYSTEMS



USE



# BARRYMOUNTS

## FOR ASSURED CONTROL of SHOCK and VIBRATION

Powerful and sensitive, compact and light-weight, this new RCA family of aircraft radio equipment is built to meet the communications and navigation needs of airline, feeder line, and executive aircraft, bush flyers, and sportsman pilots.

**For assured protection against shock and vibration in the roughest types of flying operations, RCA provides individual mounting with BARRYMOUNTS.**

With the AVR-21 Automatic Direction Finder, for example, Type M-112 BARRYMOUNTS perform satisfactorily when the unit is subjected to 10-G vibration in any of three directions, without resonance above 13 cycles.

**BARRY aircraft mounting bases are also available for rack installation . . . in standard dimensions to government specifications . . . or to exact customer's specifications.**

### Free Catalogs

give dimensions and load ratings of stock BARRYMOUNTS. Catalog 502 covers aircraft applications. Catalog 504 covers industrial and general-purpose mountings. WRITE TODAY to



THE **BARRY** CORP.

Main Office 177 Sidney St.

Cambridge 39 Massachusetts

New York Rochester Philadelphia Washington Cleveland Dayton  
Chicago Minneapolis St. Louis Los Angeles Toronto

blue and gray or brown on tan rayon gabardine.

Here's just the thing for the technical Beau Brummel.

**Television Picture-Tube** sales by RMA members to equipment manufacturers totalled 3,305,673 valued at \$92,402,520 in 1949.

More than 43 percent of these tubes ranged from 12 to 13.9 inches in diameter, those from 9 to 11.0 inches represented 34 percent, those over 14 inches 16 percent. The remainder were under 8.9 inches.

**Receiving-Tube Sales** by RMA members totalled 198,753,295 in 1949, 5.9 million under the previous year. Sales to original equipment makers were up more than a million, government purchases nearly doubled those of 1949 and exports showed only a slight decline, but replacement sales fell off sharply.

Language of electronics is difficult enough to keep up with. And now comes the language of the guided-missile field. Selected, for one reason or another, from a glossary of 752 terms defined by the Department of Defense are the following:

ATHODYD  
BABBLE  
BANG-BANG  
BEAM JITTER  
BEAM RIDER  
BRENNSCHLUSS  
BURBLE  
CANARD  
CASSEGRAINIAN MIRROR  
CHUFFING  
DITHER  
ELEVONS  
ENTHALPY  
ENTROPY  
FLAPERONS  
GANTRY  
GLINT  
GUTTER  
HYPERGOLIC  
MEADOW  
NUTATION  
OGIVE  
PHUGOLD  
PRANDTL NUMBER  
RATRACE  
STOICHIOMETRIC  
UMBILICAL CORD

Honest Injun, we made up not a single one.

**Speaking Of Missiles**, identification of American types is easy if you are hep to the code system, and if you can get close enough to read the markings on the things while still retaining your liberty and health.

The prefix letter X means *exper-*



imental, Y means *under service test*, and Z means *obsolete*. Then comes a dash.

In the next group of three letters the first designates the launching point of the missile, the second tells where it is going and the third, the letter M, merely means that it is a guided missile. The letter A stands for *air*, S means *surface*, and U means *underwater*. Then another dash.

The next letter designates the service branch by which the missile is used, A for *Air Force*, G for *Army*, and N for *Navy*. Dash.

The final number and letter indicates the model. A lower-case letter "a" means first modification, a lower-case "b" second modification. Thus X-UAM-N-3b would denote an experimental underwater-to-air guided missile used by the Navy, model 3 with a second modification.

If You Noticed last month that our front cover looked different it was because of that color strip down the left side. We blush to admit that we made up a beautiful and expensive set of plates that were perfect in every respect except for the fact that the picture had been turned just 90 degrees out of phase!

So we sawed up the plates and put in the color strip to take care of the altered dimensions. Wouldn't surprise us at all if we received compliments for the change of pace despite the fact that it was the result of a near miss.

In February (p 63) we noted that a new book titled "Natural History" would be printed with ink giving off the odor of pine forests, called for suggestions suitable for ELECTRONICS.

Rosamund Cruikshank of Portsmouth, N. H. suggests "Chan(n)el No. 5." Leon A. Wortman of Fairchild Recording suggests the odor of melting pitch ("Nothing makes an electronic engineer sit up and take notice faster.") Warren L. Holmen of Minneapolis thinks we might use "the odor that steals into the consciousness a short time after one unknowingly kicks the soldering iron from its stand while repairing a neighbor's console."

# SIGMA

## Sensitive Relays

how fast is it?



Here are two test circuits. In each case, the same relay is used, the coil current is the same and the oscillogram shows the operating time.

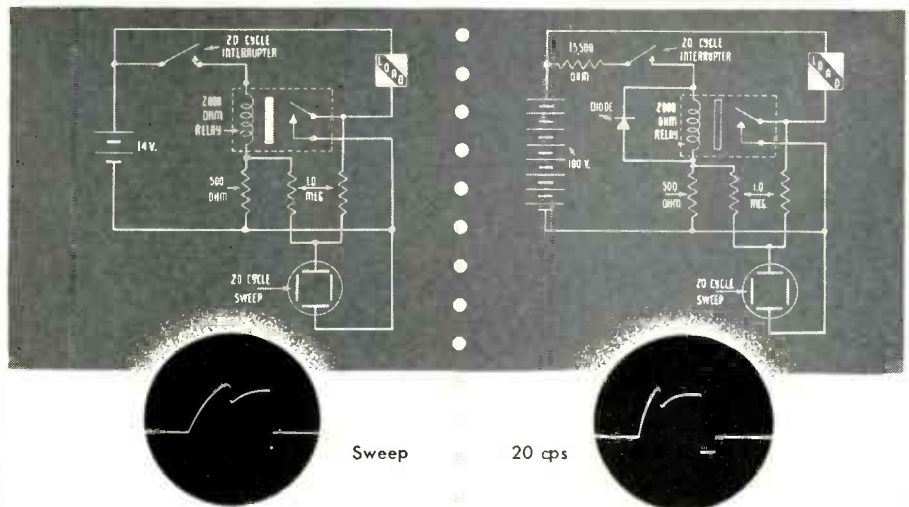

### IN THIS CASE —

The oscillogram shows a gradual rise of coil current, based on the signal derived across the 500 ohm resistor. The first downward step is caused when the relay contact in closing grounds the load and removes some of the input voltage from the scope. Reverse curvature in the trace is due to back emf induced in the relay winding by the armature motion. The next and much larger downward step is the result of opening coil circuit by the interrupter. The small dot at its lower end indicates the delay in breaking the load circuit, after which the trace moves upward from reappearance of voltage across open contacts. The whole cycle shows a substantial operating delay, and a period of contact closure much shorter than that in which voltage is applied to the coil.

### HERE HOWEVER —

Although the final relay current is identical, as is the relay, it is obvious that the electrical time constant is much shorter, the current rises faster, and the contacts close sooner. Another "wrinkle" has been introduced in the diode shown across the coil. It is polarized so as not to pass battery current; but upon interruption of the circuit, it provides a low impedance path for dissipation of the stored energy in the relay, which in the other case was dissipated in an arc at the interrupter contacts at high voltage without significant current flow. In this case, the current flow is appreciable and holds the relay on for a considerable length of time.

Not only is the relay now much faster, but the contacts are now closed for a time approximately equal to that during which the coil is energized.

Thus it is evidently difficult to state operating time of a relay unless circuit conditions are prescribed — and this is no academic qualification. (Those wishing to duplicate the above displays will recognize that the two resistors shown as 1.0 megohm should be varied to give a desirable relative magnitude to the two signals, and may in fact take the form of a potentiometer.)



Write for Catalogue

# SIGMA Instruments, Inc.

**SENSITIVE RELAYS**

62 Ceylon St., Boston 21, Mass.

**Value  
Beyond  
Expectation!**

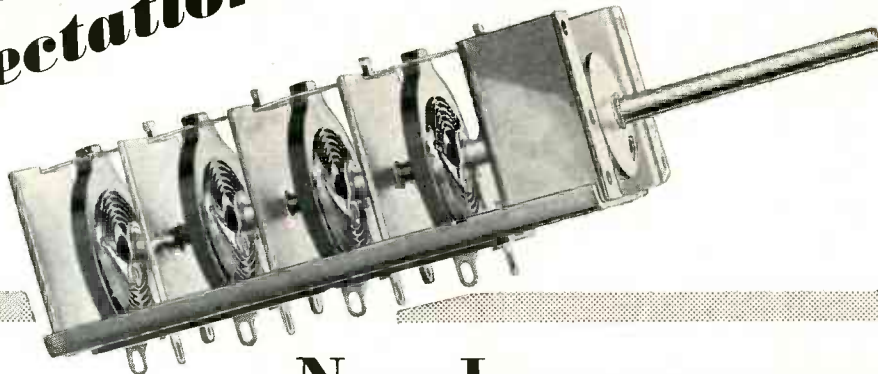

## New Improvements in Mallory Inductuner\* for Television Receivers

### Outstanding Advantages of the new Mallory Spiral Inductuner:

1. A single control for easy selection and fine tuning of any television or FM channel.
2. Easily adapted to UHF converter use.
3. Excellent stability eliminates frequency drift.
4. Supplied in three- or four-section designs.
5. Far more quiet operation; permits high signal-to-noise ratio in front end designs.
6. Free from microphonics.
7. Greater selectivity on high frequency channels.
8. Eliminates "bunching" of high band channels.
9. Simplifies front end design and production.
10. Reduces assembly costs.

\*Reg. trade mark of P. R. Mallory & Co., Inc. for inductance tuning devices covered by Mallory-Ware patents.

Now there are important new reasons why the Mallory Inductuner should be first choice for your TV receiver. Each one offers more convenience to the set owner, new economy for you, without any sacrifice in the performance advantages of the continuous tuning principle . . .

*Improved Inductuner eliminates "dead zone" from continuous tuning; covers entire TV range from 54 to 216 megacycles, including FM, in only 4 revolutions!*

*Improved Inductuner covers entire TV spectrum in only 3 revolutions, if FM is not required!*

*Improved Inductuner can be channel-indexed for touch-tuning without dial watching . . . still provides fine-tuning adjustment!*

*Finally, the Improved Inductuner is available at low cost and will make important savings for you in assembly and alignment operations.*

### That's Value Beyond Expectation!

Write for technical details. Also inquire about the surprisingly low cost and superior performance of the suggested front end designs which Mallory engineers have developed around the Inductuner.

Television Tuners, Special Switches, Controls and Resistors

#### SERVING INDUSTRY WITH

Capacitors	Contacts
Controls	Resistors
Rectifiers	Vibrators
Special	Power
Switches	Supplies
Resistance	Welding Materials

P. R. MALLORY & CO., Inc.  
**MALLORY**

P. R. MALLORY & CO., Inc., INDIANAPOLIS 6, INDIANA





## CROSS TALK

**1930** . . . Anniversaries after thirty are easiest to take if they are ignored. But *ELECTRONICS* is only twenty years old this issue, so let's get on with it.

When a magazine turns the corner of another decade, its editors turn their attention to their longtime friends, the charter subscribers. Five thousand such friends got copies of the first volume, in 1930. Of these, our records show 423 have never left us, even for a single issue. To these, and other long-term supporters of our efforts, we feel an accounting is due. Perhaps the new recruits will find the record worth recounting.

The charter subscriber who has renewed his subscription regularly at the one-year rate has paid \$91 for the issues of this magazine to date. If he took advantage of the special charter subscriber rate, and has since renewed every three years, at the three-year rate, he got the service at the rock-bottom price of \$60.

What did such a friend and supporter get for his money? He got a total of 43,700 printed pages, 15,700 of which were devoted wholly to editorial material. If he binds his volumes, text and advertising, he has a shelf-full 6½ feet long. The editorial content of 20 years, reduced to 400-page volumes of standard textbook size, fills the equivalent of 80 volumes of technical information. These he got

for 75 cents each. On the same basis, the advertising pages constitute 150 volumes—a truly encyclopedic commercial history of the electronic arts. Charter advertisers are still with us, too. Of the 74 charter advertisers still in business, 56 appeared in these pages in 1949.

So much for quantity. What about the quality? We feel satisfied that a good job has been done, but that's only a personal opinion. Several facts stand out. The average net paid circulation has increased from 5,092, in the six-month period ending December 1930, to 30,884 for the same period in 1949. The renewal percentage (an editor's bogey, having about the same force as the  $g_m$  of a 6AG5 has for the quality-control engineer, namely, you keep it up, or else) has followed the economic fortunes of business, but through the 20 years it has consistently bettered par for the course. It would appear, therefore, that reader acceptance is reasonably high.

One thing is certain. The field of electronics has grown rapidly, and the load on the staff has kept pace. In 1933, it took only 354 editorial pages to cover the electronic developments of that depression year. In 1946, when we were busy publishing the huge backlog of copy stored during the war, it took 1,319 pages. Last year, things having settled down to a steady roar, it took 1,247 pages.

The staff has grown in proportion. Initially three men and a

girl, and for one brief period reduced by sickness to two men and no girl, the editorial staff now comprises nine editors and three attractive young ladies. The editorial turnover has not been high. One editor has been with us since the beginning, and of the 18 editors whose names have appeared on the masthead at one time or another, half are still at their desks.

That is the factual record. But no recital of facts and figures can reflect the great sense of excitement, the sense of participating in a vital and fascinating profession, in a great and burgeoning industry, that has buoyed up the staff throughout these twenty years. Memories are many: The private preview of a new art at dinner in Major Armstrong's home two days before he presented his famous paper on f-m in 1935. Being hauled up before the IRE Board of Directors for scooping the *Proceedings* on the orthicon in 1939. The gratified smile on Claude Shannon's face as he handed us the corrected proofs of our report on his famous theory of noise and bandwidth in communication. These memories, and a hundred others like them, mirror the past.

As for the future, our feelings are no different. We have the same feeling of excitement that comes from dealing with active men in a vital field, the same eager anticipation for the new developments to come. . . . **1950**

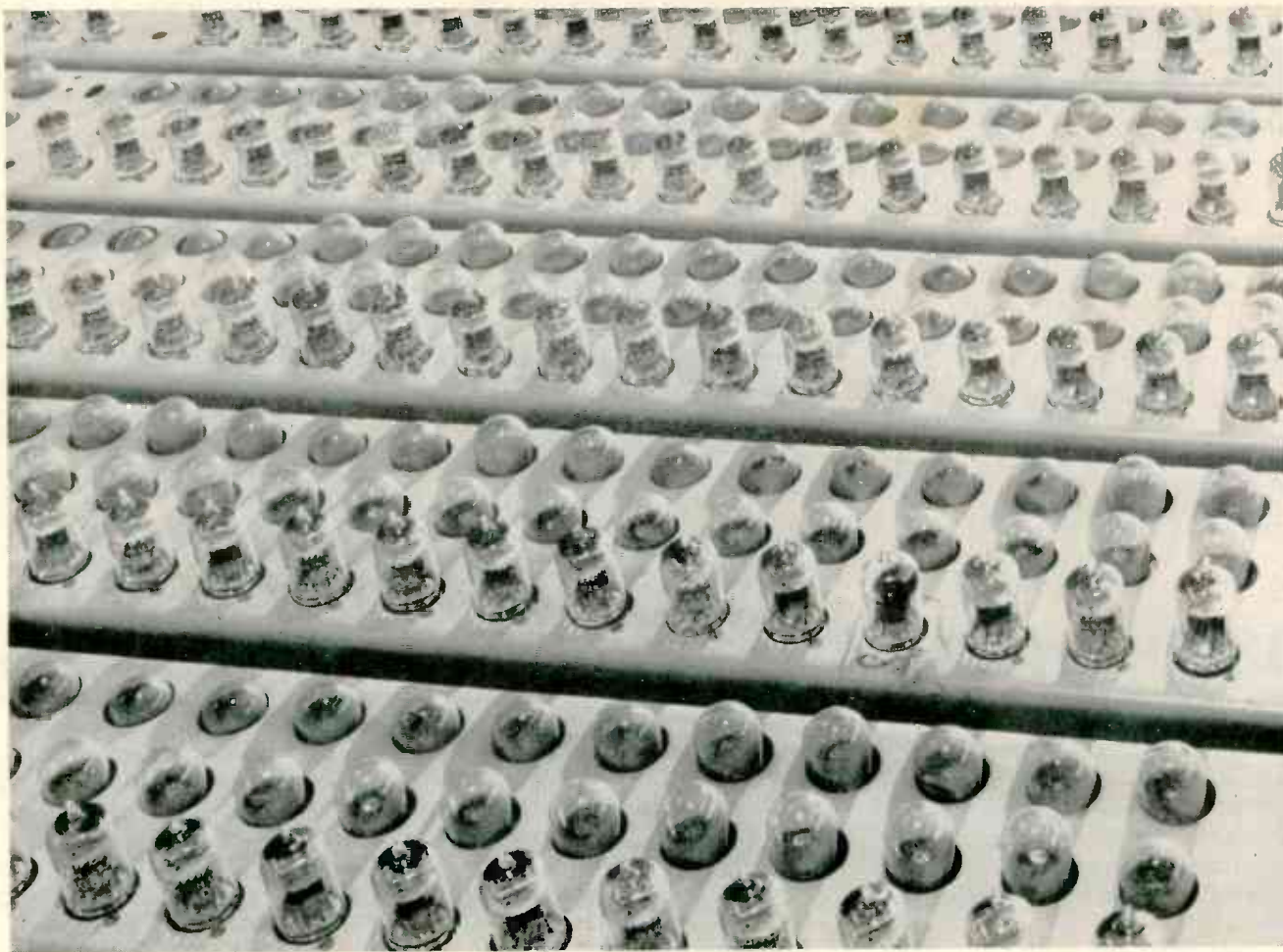

(Western Electric photo)

**T**HE PROGRESS of the electronic art through the past two decades has been of such magnitude it is difficult to assess in technical terms. The applications in communications, in industry, in applied science and in medicine are so various, that even to list them is a formidable task. It is simpler to cast the review in terms of the common denominator of all electronic development, the electron tube itself.

When this magazine was first published, in April 1930, electron tubes had been in existence for a quarter of a century, dating back to the Fleming diode valve in 1905. In that quarter century many of the basic types had made their appearance: the triode in 1907, tetrodes in 1927, and r-f and power pentodes in 1929. X-ray tubes were in wide use, and cathode-ray tubes were available, although not yet widely used in oscilloscopes. Gas-filled rec-

tifiers were in use, and the thyratron was announced in 1928. The two-plate magnetron and the dynatron had been invented. Work was under way on the iconoscope, but it had not been publicly announced. As of 1930, there the list ended.

It is not surprising, therefore, that the complete list of tubes considered to be of interest to amateurs in 1930 comprised only 41 types. The 1930 edition of the "Radio Amateurs Handbook" contained a tabulation of 11 receiving tubes, 19 transmitting tubes, 8 rectifiers and 3 current regulators. In 1930, active tubes listed in the "RCA Tube Handbook" totalled 59: 25 receiving types, 32 transmitting types and 2 others.

Those were the good old days! The 1950 edition of the ARRL Handbook lists 1,189 types, an increment of 28 new tubes for every one listed in 1930. The active tubes in the RCA list doubled in number

every five years until 1940, and have nearly doubled again since then. There are 689 types in the HB-3 catalog as of 1950. This represents in 20 years, an increase of nearly 12 times in the output of one company alone.

The cumulative record of tube development throughout the years, in all countries, is beyond estimation. But some idea of the proliferation in tube design can be derived from the listings of the 1949 "International Radio Tube Encyclopedia," which encompasses most of the tube-type designations, in nine classifications, manufactured throughout the world. The total is 10,424 tube types! An accompanying table gives the details of this prodigious record. Note that it contains 80 different types of tuning indicators, 787 cathode-ray tube types, and 4,891 receiving tubes.

Production of tubes has reached well into the billions. Well over



# ELECTRON TUBES

## 1930 TO 1950

The history of electronics revolves around tubes. Two decades have seen the marketing of over 10,000 types, worldwide production approaching five billion units, and over thirty major advances in design

three billion receiving tubes have been made in the U.S.A. alone. Receiving-tube sales averaged about 50 million annually from 1930 to 1935. Since the war the rate has been 200 million or more annually. During the war even higher figures were reached. One series alone, the proximity-fuze tubes, achieved a total production of 130 million.

### **Technical Advances in Tubes**

So much for tube types and production. Of greater interest to engineers are the technical advances revealed in new electron-tube principles.

During the past twenty years, no fewer than 34 electron tubes essentially new in principle have appeared. These represent no mere changes in envelope, basing or heater voltage; they are basic advances. First on the list is Stuart Ballantine's variable-mu tube. Last is the electron coupler, described to readers of this journal only last month. Included in the list are the whole family of television camera tubes, from iconoscope and image dissector to image orthicon; the electron accelerators from cyclotron to betatron and synchrotron; all the electron multipliers; the electron optical tubes, electron microscope and infrared image converter; all the uhf and shf family, from klystron and resnatron to the cavity magnetron. Included also are such workhorses as the beam-power tetrode.

Along with these new ways of

controlling free electrons to perform new tasks, steady progress has occurred in mechanical structure to make tubes more rugged and reliable, more efficient in the use of filament and plate power, more comprehensive in frequency range. Part of this mechanical effort has led to changes in envelopes and basing practice. Typical trend is the jargon of the bases: octal, loctal, noval, magnal, duodecal and diheptal. Some tubes have "gone small" and others are enormous, from the miniatures and subminiatures on the one hand to the recently announced 500-kilowatt triode on the other.

### **I—The Electron Image**

Certain trends are discernible in the roster of the new tube principles and structures. In view of the present status of television, one of the most important of these trends is that based on the electron image. The basic idea of creating and storing a pattern of electrons which corresponds point for point with an optical image goes back to the suggestion of Campbell-Swinton in 1908, but a practical embodiment was not publicly described until 1933, when Zworykin gave his paper on the iconoscope before the IRE at Chicago. Concurrently, the concept of the electron image had been used by Farnsworth in the development of his image dissector, which he first described before the Franklin Institute in 1934.

At about the same time, the elec-

### **Two Decades of New Tubes**

*A Chronology of Electronic Principles (With date of first mention in Electronics)*

- VARIABLE-MU, Jan '31, p 472
- COLD-CATHODE RECTIFIER, Nov '31, p 182
- IGNITRON, June '33, p 164
- ICONOSCOPE, July '33, p 188
- ELECTRON MICROSCOPE, Sept '33, p 243
- SHIELD-GRID THYRATRON, April '34, p 114
- ELECTRON MULTIPLIER, Aug '34, p 242
- IMAGE DISSECTOR, Oct '34, p 300
- CYCLOTRON, Nov '35, p 421
- IMAGE CONVERTER, Jan '36, p 10
- DEFLECTION CONTROL, March '36, p 14
- BEAM POWER TETRODE, April '36, p 18
- STROBOTRON, Feb '37, p 12
- MOVABLE ANODE, March '37, p 16
- MULTIPLIER PHOTOTUBE, March '38, p 38
- ORTHICON, July '39, p 11
- KLYSTRON, Nov '39, p 13
- RHEOTRON, Feb '42, p 22
- RADIAL BEAM, Aug '44, p 214
- ORBITAL BEAM, May '45, p 103
- T-R, Nov '45, p 104
- IMAGE ORTHICON, Dec '45, p 330
- CAVITY MAGNETRON, Jan '46, p 126
- BETATRON, Jan '46, p 156
- RESNATRON, Feb '46, p 92
- PHASITRON, Feb '46, p 204
- SKIATRON, Oct '46, p 216
- HYDROGEN THYRATRON, July '46, p 96
- TRAVELING WAVE, Nov '46, p 90
- MEMORY, Sept '47, p 80
- BEAM DEFLECTION MIXER, May '49, p 76
- POLYCATHODE GLOW, Nov '49, p 92
- GATED BEAM, Feb '50, p 82
- ELECTRON COUPLER, March '50, p 80

tric-optical researches of Knoll and Ruska led to the development of the electron microscope. In 1936, the "electron telescope", an image converter which translates directly from infrared to visible light, was announced. In 1939 came the orthicon, a low-electron-velocity version of the iconoscope, and in 1945 the image orthicon. This latter device, considered by many to be the crowning achievement of electron tube development, employs the principle of electron multiplication, itself developed as late as 1934, to achieve sensitivity to light surpassing the fastest photographic film.

### The International Record to 1949

(Tube Types listed in "International Radio Tube Encyclopedia")

Radio Receiving .....	4,891
Triode Transmitting .....	1,598
Rectifiers .....	1,468
Cathode-Ray .....	787
Tetrode and Pentode Transmitting .....	533
Regulator and Control .....	450
Thyratrons .....	333
Phototubes .....	284
Tuning Indicators .....	80
<b>Total .....</b>	<b>10,424</b>

Last year, a new storage tube was briefly described which equals the sensitivity of the eye.

### II—The Electron Group

Early tubes were designed on the basis of collecting the electron current at the plate of the tube, thus transforming the space current directly into a conduction current in the circuit attached to the plate. But, with the development of the magnetron, a wholly new means of extracting the energy from electrons was conceived. This consisted of whirling, or otherwise moving, a group of electrons past electrodes with which they did not actually make contact, and relying on the field of force surrounding the electron groups to induce current in the electrodes. This principle was put to work in the early magnetron and

its modern progeny, the cavity magnetron. It has appeared in different forms in many other high-frequency tubes, including the klystron and the traveling-wave tube.

The electron-induction principle has been applied in reverse in one of the most important groups of machines in modern technology, the particle accelerators of nuclear science. Starting with the cyclotron in the early thirties, charged particles have been whirled at speeds approaching that of light, and at energies approaching a billion electron volts, in successive variations of the cyclotron principle; the f-m cyclotron, the betatron, the synchrotron and the bevatron.

So far as frequency of operation is concerned, the electron-grouping technique is clearly responsible for the extension of radio transmission and reception to the region above 1,000 mc, although triode structures have penetrated above this limit in a few cases. Part of the technique has been the inclusion within the tube envelope of one or more tuned circuits, which receive their excitation from the passing groups. The most noteworthy example of the latter class in the cavity magnetron, which has extended the radio spectrum above 30,000 mc, and has achieved peak power levels of the order of megawatts at somewhat lower frequencies.

### III—Scaling Down

The urge toward higher frequencies has inspired designers to follow the obvious, but difficult, trail of reducing the size of tube structures and the spacing between elements. One of the first examples of this trend was the acorn tube, one type of which (the 6F4) is still rated as one of the best high-frequency triodes, operating up to 1,200 mc.

Just before the war, the button-stem miniature tube appeared. It was originally designed for personal portable radio receivers but was quickly appreciated as a true advance in high-frequency design. The disk-seal lighthouse tube followed, noteworthy for its integration with external cavities for tuned circuits. Still another form was the pencil triode. Subminiature tubes, initially designed for hearing aids, and later

adapted to the proximity fuze, have achieved exceptional high-frequency performance, coupled with low power consumption. The proximity-fuze tubes had not only to be small but also had to withstand tremendous mechanical shock, 20,000 times the acceleration of gravity in artillery applications.

### IV—Transconductance Up

A similar trend has affected the design of electrode structures, particularly as related to mutual conductance. The battery triodes prior to 1930 (UV199 and WD-11) were hardly distinguished by modern standards. Each had a mutual conductance less than 500 micromhos, and the power output tubes (112A and 71A) as well as the early pentodes (77 and 78) got no higher than 1,500 micromhos. With the advent of the heater-filament power pentode, and particularly when the beam-power tetrode appeared in 1936, conductances began to rise, reaching 6,000 micromhos in the 6L6 beam tetrode.

When wideband-amplifier design became important about 1936 with the advent of the 6-mc television channel, attention was directed toward combining high transconductance with low input and output capacitance. One of the early successes was the type 1852, later renamed 6AC7, which achieved a conductance of 9,000 micromhos, with an input-output capacitance sum of 16  $\mu\mu\text{f}$ . This type, with its remote-cutoff sister the 1853/6AB7, became the standard wideband i-f amplifier tube in early television receives.

Came the war and radar, and the need for better tubes forced still further reduction in cathode-grid spacing and finer control-grid windings. Button-stem tube construction was adapted to assist in high-speed production and from it came the 6AK5, a pentode with 5,000 micromhos conductance and a capacitance sum of only 6.8  $\mu\mu\text{f}$ . Putting this tube in high-speed production left many an engineer prematurely gray, but at the end of the war it was the most widely used wide-band tube. Too costly for post-war commercial television sets, it was replaced by a watered-down version known as the 6AG5.



The ultimate in the brute-force, or make-the-triode-do-it, school of design is the co-planar triode designed by the Bell Laboratories for microwave relays. This tube (BTL 1553) has a transconductance value of 5,000 micromhos, coupled with a capacitance sum of 10  $\mu\mu\text{f}$ . It will amplify at 4,000 mc, over a bandwidth of 60 to 80, with a gain of 4 to 6 db per stage. Old hands said this improbable tube was impossible to build on a production basis, but it's being built. The grid-cathode spacing is six ten-thousandths of an inch, the grid wires a third of a mil in diameter and wound 1,000 turns to the inch. Viewed on this scale the surface of an ordinary oxide cathode is mountainous; to make it plane, the surface is milled off as though it were a Johannsen block.

#### V—Photosensitivity

The phototubes have been in many respects a family apart, but that is not to say that the photosensitive designers have been inactive. Two main avenues of improvement have been followed: extension of the spectral responses toward the blue and ultraviolet, and vast increases in overall sensitivity.

In 1930, virtually the only photo-surface in wide use was the cesium-oxide-silver, or S-1 photoemitter, which displays an overwhelming preference for infrared radiation in the region of 8,000 Angstrom units. Five new surfaces now grace the handbooks (S-3, 4, 5, 8 and 9). All of these have essentially no infrared response, but have peaks in the blue region, or just over the border into the ultraviolet. Surface S-9 ex-

tends into the green region, and has a spectral distribution not markedly different from that of the eye. Taken together, these photoemitters, with various optical filters, can cover adequately the visible spectrum, and well into the infrared and ultraviolet.

As for sensitivity, use of the electron multiplier in phototubes affords an increase of the order of a million times. The 917 vacuum phototube, widely used before the war, has an average luminous sensitivity of 20 microamperes per lumen. The gas-filled phototube of similar vintage (type 868) hits about 90 microamperes per lumen. But the 931-A multiplier phototube, which dates from 1940 or thereabouts, hits an average sensitivity at full rating of 10 amperes per lumen, and an especially sensitive tube may reach 300 amperes per lumen. This tube will produce a signal just equal to the noise when the light falling on the photoemitter is 10 billionths of a lumen, i.e. it will register the light from a tallow candle at three miles. For the affluent, the 1P21 multiplier, at five times the price, goes down to half a billionth of a lumen. The catalog description of the latter

tube "for applications involving very low light levels" is something of an understatement.

#### VI—C-R Tubes in Job Lots

This review of tube progress must obviously conclude with the class of tube responsible for more vacuum than all other types combined, the cathode-ray picture tube. Here the improvements have been various: in the electron gun focus is now maintained over a wider range of beam current, and the first anode current has been markedly reduced. The negative ions are forcibly removed from the cathode-ray by the bent-gun or the inclined-slot gun, in conjunction with ion-trap magnets. Phosphors are more efficient and considerably more uniform than before the war. Phosphor coatings are of two kinds: aluminum behind the screen to increase luminous output and to control negative ions, and "blaxide" in front to take the extra brightness away and enhance contrast.

The evolution of the c-r tube envelope is preponderantly a post-war phenomenon, and the end seems not in sight. The super-heavy face plate has given way in the larger sizes to the metal-sided construction. The aspect ratio, in bondage for several years, seems about to be redeemed as the rectangular-faced tube makes its appearance. Not the least of the c-r tube accomplishments are the production and price figures attained. Over 3 million picture tubes were produced in 1949, and the manufacturer's price for a 16-inch tube had descended to \$29.00 as of April this year, about that for a 10-inch tube in 1947. Future progress, in these as well as other types of tubes, may be hard to describe. But it can be counted on.—D.G.F.

#### Evolution in One Company

(Active Types in the RCA Tube Handbooks)

	1930	1935	1940	1945	1950
Receiving .....	25	84	235	269	387
Transmitting .....	32	46	70	85	114
All Others .....	2	13	63	107	188
Total .....	59	143	368	461	689

#### American Tube Types

(As listed in the ARRL "Radio Amateurs Handbook")

Type	1930	1950
Receiving .....	11	584
Transmitting (to 1 kw) .....	19	302
Rectifiers .....	8	129
Cathode-Ray .....	..	65
Cavity Magnetrons .....	..	50
Control and Regulators .....	3	37
Klystrons .....	..	22
Total .....	41	1,189

# UHF TELEVISION

First experimental satellite station installed for long-term evaluation of uhf television reception. Standard transmitter, supplemented by cavity tripler and output stage, feeds slot antenna. Printed circuits used in adapter to convert standard receivers

By **RAYMOND F. GUY**

*Manager  
Radio and Allocations Engineering  
National Broadcasting Co., Inc.  
New York, N. Y.*

**T**HE ASSIGNMENT of uhf channels to television service can be intelligently made only if certain basic facts are available in advance. The kinds of information needed are:

(1) The distances at which a given field strength can be produced by a station when it utilizes practical antenna heights, transmitter powers that are economical or possible to attain and transmitting antenna gains that are optimum.

(2) The service range as it is ultimately limited by noise produced in receiver input circuits, relative to the field strength. Receiver noise figures must be known and evaluated.

(3) The efficiency of practical receiving antennas and associated transmission lines.

(4) The effect of earth prominences, buildings and other obstructions that cause diffraction, shadows and multipath effects, depending upon height and the type of knife-edge over which the signals pass and distance.

(5) The amount of signal variation from hour to hour and from season to season resulting from changes in the troposphere.

(6) The distances at which the station will produce field intensities capable of causing interference to other stations on the same channel.

(7) Finally, geographical and frequency assignments must be made with a view towards reducing cochannel and adjacent channel interference to tolerable levels, using practical transmitters and receivers.

Since 1946, attempts have been

made to evaluate the service potential of the ultrahigh frequencies, particularly in the region between 475 and 890 mc. The results obtained by several investigators are available in the literature<sup>1, 2, 3, 4</sup>.

It was decided that the next step must be the construction and operation of a complete uhf television broadcast station in a representative community. Every part of the facility was custom built to insure

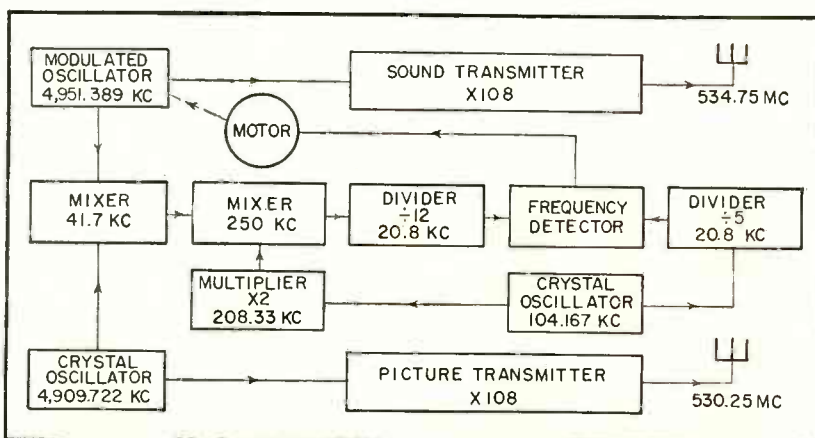

FIG. 1—Modified frequency control keeps sound carrier 4.5 mc above picture

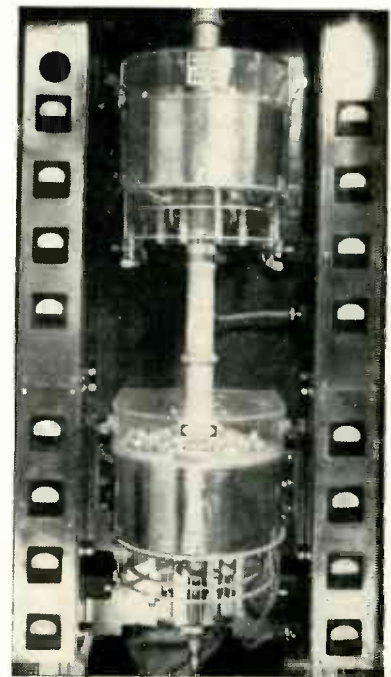
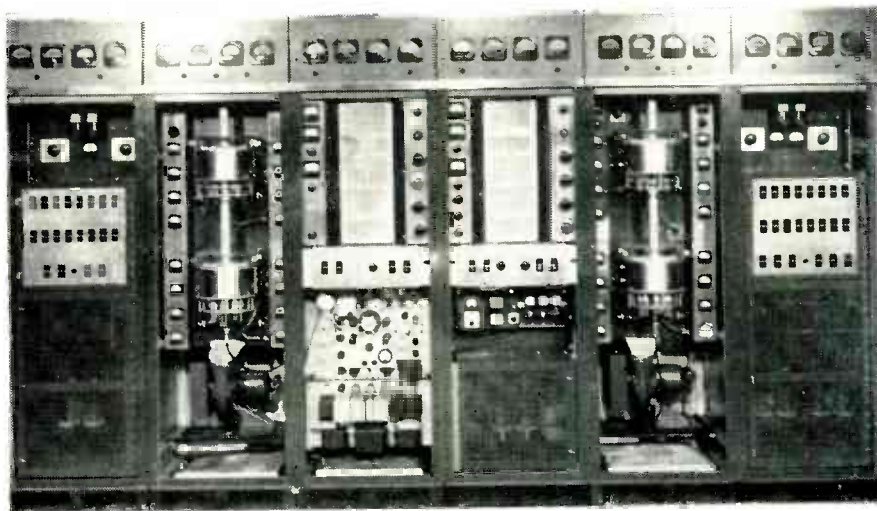

FIG. 2—Tripler cavity surmounted by output cavity. Identical units are employed for the sound and picture transmitters



# FIELD TEST



Complete uhf television transmitter. F-m sound transmitter at left and picture transmitter at right. Output cavity circuits arranged vertically are identical and are shown in more detail in Fig. 2. Frequency control is left of center



Bridgeport-Stratford uhf station and transmitting tower. Program receiving antenna is at 160-foot level

that the performance would be truly representative of the uhf television transmission conditions, in an area typical of those in which many uhf stations will later be operated.

The site finally purchased is located in Stratford, Connecticut, near the Stratford-Bridgeport boundary, on Success Hill, one of five hills surrounding Bridgeport on the land side and about 2.5 miles distant from the center of the city. It was chosen for its central location, altitude of 190 feet, minimum of shadow problems, relative isolation and because there were few zoning restrictions. About 350,000 people, half of whom reside in the city of Bridgeport, live within the area served.

The transmitter building is a one-and-a-half-story frame structure about 24 by 34 feet with floor area of 1,164 square feet. The basement is used by the RCA Service Co. in connection with the installation of receivers in the area.

The transmitting antenna is supported by a 210-foot fabricated tower rising to an overall height of 443 feet above sea level. At the 160-foot level is located the directional dish antenna used for pick-

ing up programs from WNBT on Channel 4 in New York, 53 miles away. A 2,000-mc link is alternatively employed to modulate the transmitter.

Application for construction permit was filed Feb. 8, 1949 and the first transmissions with full power and modulation were made December 29, under the call letters KC2XAK. A total of 50 television receivers with uhf converters is being installed for qualitative tests and field strength measurements with mobile equipment are being made in the area.

When it became apparent some

years ago that television service would have to expand into the uhf region, work was started on the development of tubes and circuits to provide satisfactory apparatus at adequate power to meet anticipated requirements. The KC2XAK transmitting plant, relatively simple in design, depending heavily upon existing commercial equipment, is suitable for commercial operation on actual program schedules. Many improvements are planned and will be employed before the termination of the tests. In particular, it should be remembered that the present operation

## Highlights of the Bridgeport Installation

- Sound-carrier frequency control maintains intercarrier separation of 4.5 mc
- Tripler and output cavities adapt standard equipment to uhf
- Receiver-characteristic visual monitor
- Vestigial sideband filter for uhf
- Notch diplexer for feeding picture and sound signals to antenna through a single coaxial line
- Special transmission line between transmitters and antenna
- New slot-type antenna with 88 apertures, vertical beam width of 2 degrees and power gain of 17
- Special tuners with printed-circuit filter for survey with standard receivers

will be in the 529-535 mc region. Different techniques will be necessary at 900 mc.

Basically, the transmitter comprises a type TT-500B 500-watt commercial vhf unit delivering picture power at 176.75 mc and sound power at 178.25 mc, followed in each case by a tripler and power amplifier. Sound modulation is conventional. Grid modulation of the picture power amplifier is accomplished by eight parallel type 6L6 tubes operating as cathode followers. Performance conforms to standard vhf practice. The transmitter operates with a power output of 1 kw on sync signal peaks.

*Sound Carrier Frequency Control.* Because of the very small

amount of deviation (25 kc) employed for frequency modulation of the sound channel at the operating frequency (534.75 mc) it is necessary to maintain the center frequency exactly in order to reduce noise. Because many receivers employ the intercarrier system, it is further necessary that the sound frequency be maintained exactly 4.5 mc higher than the picture frequency of 530.25 mc.

For these reasons, the center-frequency control of the sound transmitter depends upon a crystal reference chosen to compensate for variations of the picture transmitter crystal control circuit. The method of maintaining the required 4.5-mc difference, shown in Fig. 1,

involves a slight modification of the customary commercial equipment.

As shown in the block diagram, the output frequency of the picture transmitter depends upon a crystal oscillator and a frequency multiplier of 108 times. Output from this 4,909.722-kc crystal oscillator is fed to a mixer and the 41.7 difference between this and 4,951.389 kc from the sound-channel modulated oscillator is fed to still another mixer. This mixer adds the multiplied output from the 104.167-kc difference crystal oscillator and feeds approximately 250 kc through a divider to the frequency detector. The difference between the variable signal near 20.8 kc and a 20.8-kc signal derived from the difference crystal oscillator actuates the motor control that tunes the modulated oscillator. As soon as the modulated oscillator is brought exactly to 4,951.389 kc, both inputs to the frequency detector are at the same frequency and the motor remains stationary.

Since the maximum amount of frequency deviation for 100-percent sound modulation amounts only to about 230 cycles at the modulated oscillator, and because the amount of effective deviation in the control circuits due to modulation is further reduced by mixing and dividing, sound modulation cannot significantly affect this frequency control. The separation is therefore maintained at 4.5 mc within plus or minus 450 cycles.

*Tripler and Output Cavities.* The assembled tripler and output cavities are shown in Fig. 2, with input at the bottom, output at the top. Eight type 4x150 tubes are used in parallel in each cavity, with

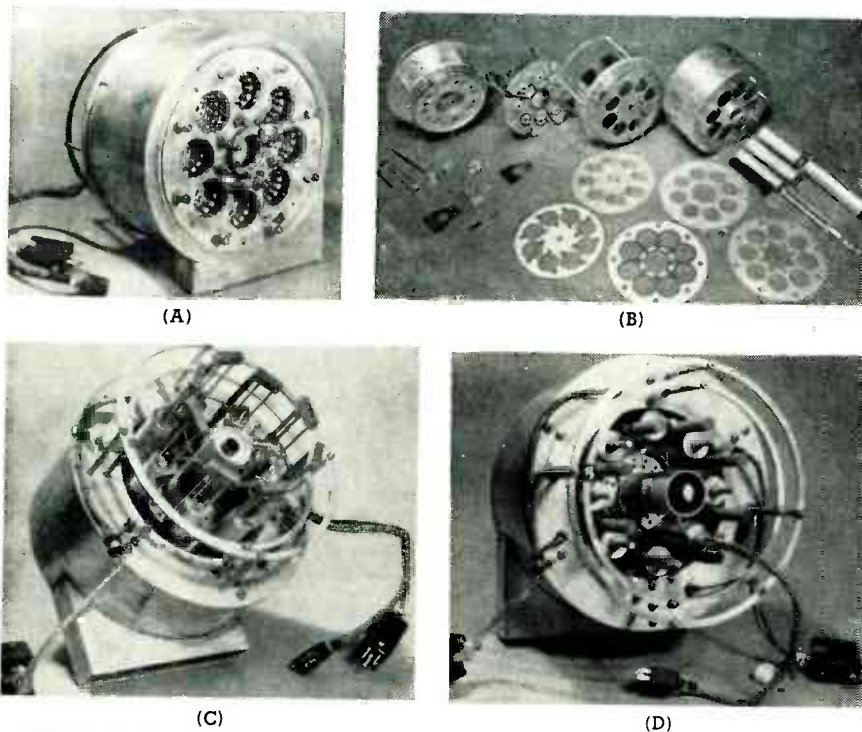

FIG. 3—Detail of cavity for eight 4X150 tubes. Tuning of tripler is shown at (C) and output tuning adjustments in (D)

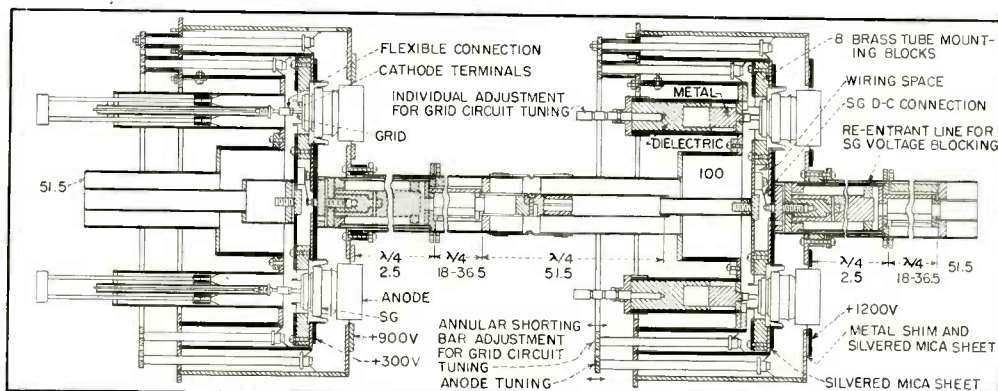
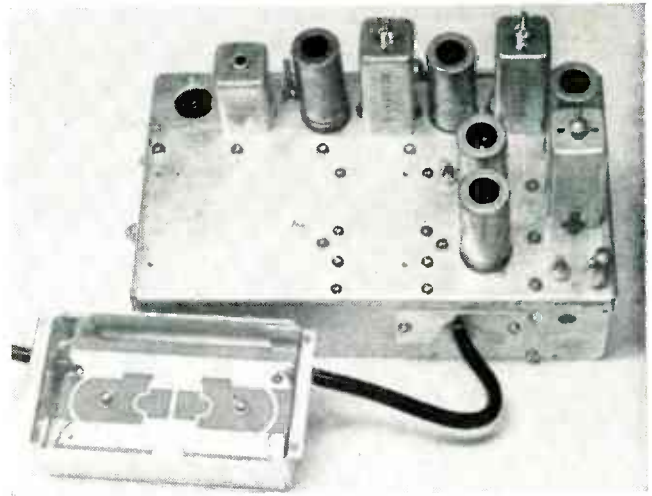
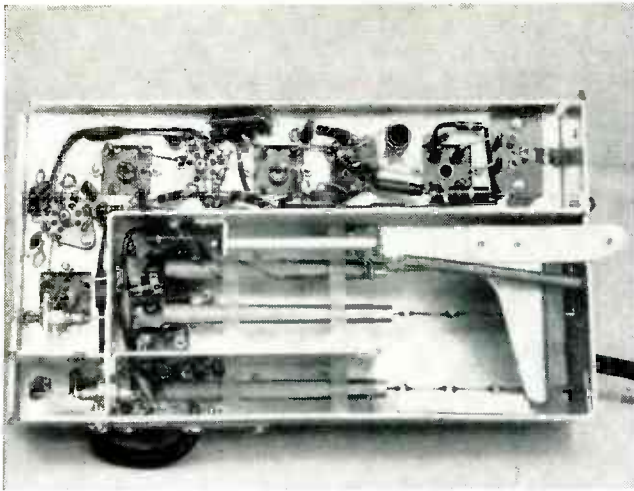

FIG. 4—Cross-section of tripler and output cavity units. Input to tripler is from the left and output from final at right. Cavities are actually mounted vertically as shown in Fig. 2





Under-chassis of uhf tuner showing slug tuning arrangement

Top view of uhf tuner with printed high-pass filter exposed

anodes visible at the top, beneath transparent covers. These covers serve both to protect the operators from plate potential and to build up a slight pressure that forces the cooling air downward past the grid seals. They are interlocked to avoid damage to equipment as well as to insure safety of personnel from plate potential.

In the closeup of the tripler unit (Fig. 3A) the tubes and output connection have been removed. The upper fingers seen through the tube apertures make contact with the anode, while the inner fingers connect to the screen grid. A typical cavity unit is shown disassembled in somewhat greater detail in Fig. 3B.

The grid and plate cavities are tuned by annular shorting bars connected for mechanical convenience to the rings shown in Fig. 3C and 3D. Additional individual grid-

circuit compensation is provided through the manipulation of controls to be seen in the photograph and Fig. 4. Equivalent grid circuits for both tripler and amplifier are shown in Fig. 5. The grid-cavity adjustment is shown as  $L_1$ . Because each tube contributes its own input capacitance  $C_1$ , an adjustment  $L_2$  is provided for each tripler tube (Fig. 5A). Various combinations of  $L_1$  and  $L_2$  can tune the circuit to resonance, but each combination presents a different input impedance. Thus, the input circuit can be adjusted to the 51.5-ohm cable connecting the tripler to the output of the modified driver. The r-f grid voltage on each of the eight tubes is balanced by adjustment of the eight  $L_2$  circuits.

Although the grid circuit (Fig. 5B) of the amplifier stage is essentially similar to that of the tripler, the input impedance is designed

for about 100 ohms. Because of the higher operating frequency, the grid-lead inductance  $L_2$  becomes more significant and requires compensation in the form of series capacitance,  $C_2$ . A dielectric sleeve slides between two conductors to vary the capacitance in this equipment. In the amplifier, the grid is not returned to ground for modulation frequencies. Video signal is introduced to the grids through quarter-wavelength sections of transmission line (not shown).

The plate circuits of the triplers and amplifiers are identical and differ in operation only in the amount of loading coupled into the circuits. The output load impedance is matched by two quarter-wave transformers in series, one of which is variable to adjust the load on the tubes. The characteristic impedance is changed by varying the spacing between the inner and outer conductors of the coaxial transmission line section. Physically it is accomplished by rotating the outer conductor with respect to the inner conductor approximately as shown in Fig. 6.

Monitoring equipment includes required indicating instruments for the sound and picture channels as well as scope presentations of waveform and picture for the picture transmissions. Here, again, standard equipment has been adapted at moderate cost for use at uhf. The transmitter frequencies are heterodyned to 49.75 and 45.25 mc (formerly used for television channel 1)

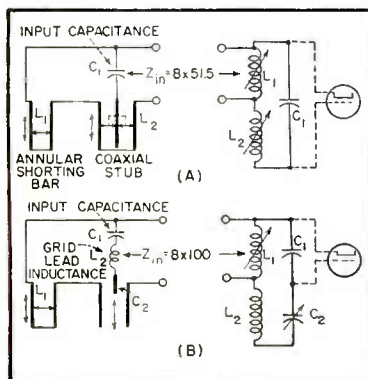

FIG. 5—Equivalent grid circuit of tripler (A) and output amplifier (B)

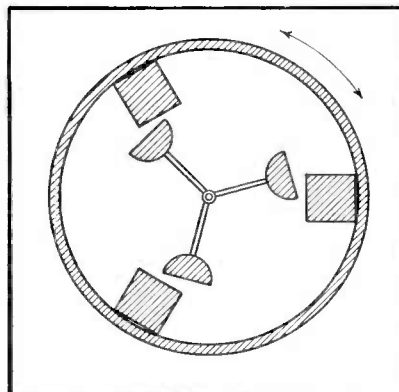

FIG. 6—Variable impedance coaxial line transformer, tripler to final

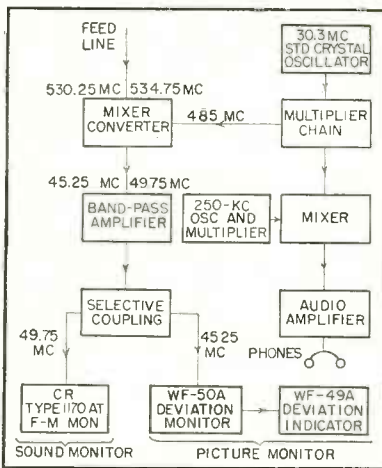

FIG. 7—Frequency monitoring equipment adapts existing vhf gear to uhf

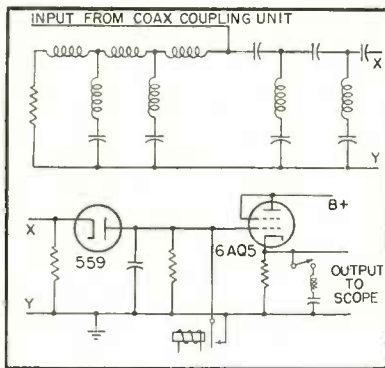

FIG. 8—Visual monitor and modulation converter produces characteristic similar to that from home receiver

amplified and then filtered for use in the appropriate separate monitors. As shown in Fig. 7, a crystal oscillator at approximately 30.3 mc is multiplied to 485 mc to beat with

the transmitted signals. This oscillator has a frequency stability of 2 parts per million per 30 days. Any drift is checked against a 250-kc oscillator-multiplier which in turn is checked against standard frequency transmissions from WWV.

**Receiver Type Visual Monitor.** Modulation monitoring of the picture channel after the sideband filter is obtained with a standard demodulator. A special diode detector connected ahead of the vestigial sideband filter permits oscilloscopic observation of the envelope of the double sideband output. The vestigial sideband demodulator is a tuned r-f type receiver of low sensitivity using coaxial line circuit elements. It employs a constant resistance filter of the  $m$ -derived type. This design assures stability of the cutoff point on the receiver response curve and compares with the receiver characteristic contemplated in current standards. In addition to the video information which corresponds to the picture received at a distant point, the converter supplies a 100-percent modulation signal in the white direction. The schematic diagram is shown in Fig. 8. An absorption filter tuned to the carrier beat frequency between picture and sound carriers can be switched out for measuring square-wave response. The tuned relay shorting device supplies a reference level for measuring modulation depth and percent sync.

**Sideband Filter.** The picture transmitter output circuits are connected to a vestigial sideband filter employing coaxial-line circuit elements as shown in Fig. 9. Although this filter is basically similar in design to vhf units, the shorter physical lengths resulting from the higher frequencies of transmission make possible a more economical design of the circuit elements.

**Notch Diplexer for Single Line.** The picture and sound outputs are brought together in a notch filter employing coaxial line elements to combine the two outputs in one antenna feed line with very high attenuation looking backward towards the individual transmitters. Except for the smaller physical dimensions at the operating frequency, this type of circuit construction is well known and has been described in the literature<sup>8</sup>. It is shown in the photograph with the vestigial sideband filter.

**Special Coaxial Line.** Power is delivered to the antenna through a special 3½-inch diameter coaxial transmission line having a measured attenuation of 0.6 db and standing-wave ratio of better than 1.1.

For the particular experimental installation, a variation of standard beaded coaxial line was instead employed.

To minimize reflections caused by the special insulating beads that support the inner conductor from

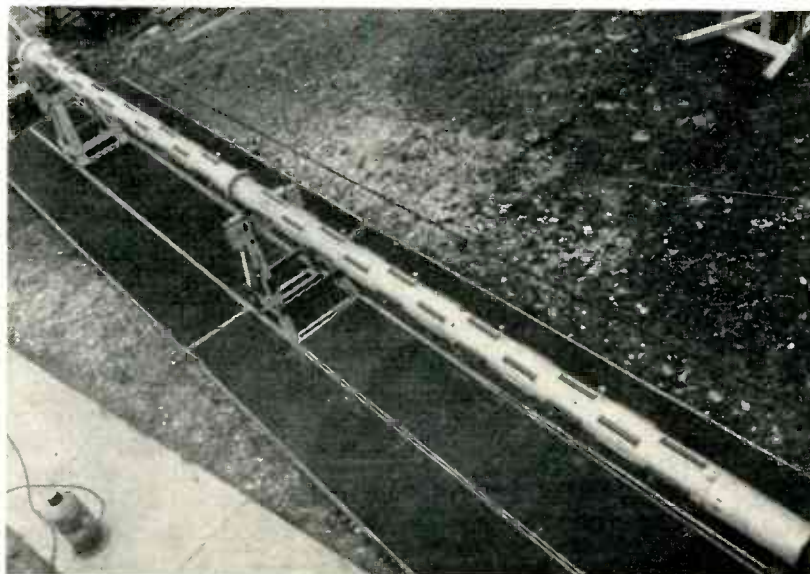

Adjusting the high-gain slot antenna. Wire mesh and space cloth beneath make possible testing in horizontal position



the inside of the outer conductor, a special undercut-bead construction is employed.<sup>6</sup> Figure 10 (not drawn to scale) shows how the inner conductor ends are connected by means of a plug. The annular grooves cut into the plug concentric with the axis of the transmission line to reduce transmission line discontinuities. There are three supporting insulators in a 20-foot length of line. The space between these insulators is approximately uniform.

**High Gain Slot Antenna.** Studies of propagation and coverage difficulties in the uhf region indicate that appreciable power will be needed as contrasted with that required on the higher vhf television channels. Because of the difficulty of generating power at uhf and because antenna structures are physically small, the additional power requirements are most easily realized by means of an array.

The bat-wing antenna elements of the superturnstile arrays require separate feed lines to each group of elements. Since it is desired to realize the highest practical antenna gain, the number of sections must be increased over the usual number employed at very-high frequencies. The slot type antenna provides somewhat greater simplicity in the feed system and was employed in this station. A four-sided slot antenna for 500 mc has a diameter of about 10 inches which is sufficiently large to elimi-

nate structural problems. By choosing a theoretical gain of 20, a vertical beam width of the main lobe of about 3 degrees at the half-power points results. Sufficient power is available in subsidiary lobes and nulls directed below the horizontal to fill in for local coverage overshoot by the main lobe. A horizontal pattern circular to plus or minus 1 percent is obtained with the 22 sets of four slots alternately arranged at 45-degree physical intervals about the supporting pole. This staggering was employed to obtain proper coupling between sections. The measured pattern of an antenna 40 feet long shows the vertical beam width of the main lobe is about 2 degrees at half-power points, with a power gain of better than 17.

The method of illuminating the slots is indicated in Fig. 11. The inner conductor of the coaxial feed is extended, beginning at the center of the antenna, by a section of the same diameter as the outer conductor. Adjustable probes are provided for each slot and have been individually turned in to the proper depth. Relation of the slots and probes is shown at the left. Additional probes spaced between those used to feed the slots are adjusted to eliminate the discontinuities caused by the pickup probes.

The photograph shows the antenna undergoing adjustment tests. In order to avoid the mechanical complications that would arise if

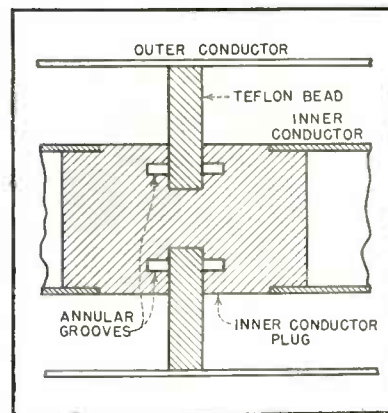

FIG. 10—Approximate representation of undercut bead construction for output coaxial line

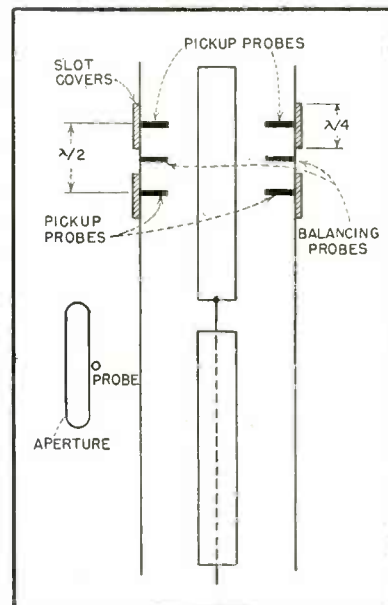

FIG. 11—Simplified diagram of slot antenna feed system. Relation of exciting probe to aperture is shown at left

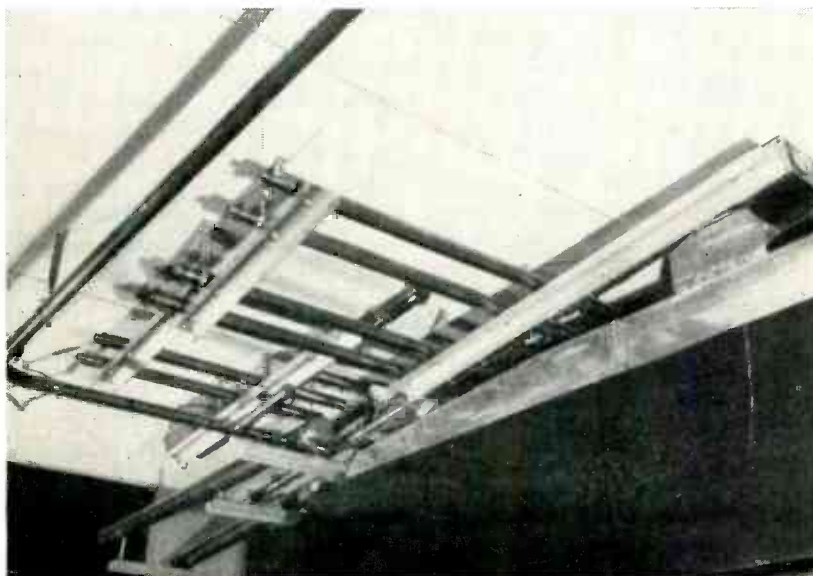

FIG. 9—Vestigial sideband filter with coaxial line elements extending to left is above the transmitter. Notch filter of larger line extends to rear

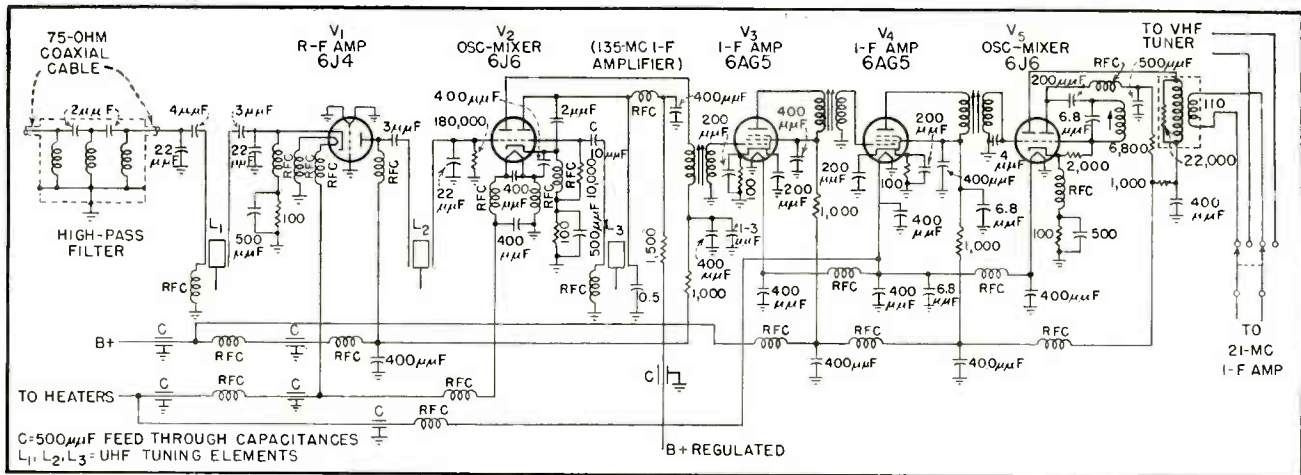

FIG. 12—The uhf tuner feeds output to i-f of conventional television receiver through switch at right

the adjustments had to be made with the antenna in the vertical position, a special surface was built under the horizontal antenna supports. Such an antenna designed for vertical use could not normally be adjusted so close to the ground because of reflected energy that would nullify that emanating directly from the radiator. For this work, a wire screen mounted in a suitable mechanical framework of wood was placed below the antenna as shown. The screen is backed up a quarter of a wavelength away, by "space cloth" having a resistance of 377 ohms per unit square. To the recumbent antenna, the space below appears much like the space with which it is otherwise surrounded. Space cloth is a fabric impregnated with graphite and a binder.

### Receiving Equipment

Because the Bridgeport transmitter operates in the lower region of the uhf band, it has been possible to attain satisfactory performance using conventional tubes in both a tuner and a converter that covers the range from 500 to 700 mc. The units to be described do not represent finished commercial design, but are experimental models produced for obtaining reception data when connected respectively to the i-f amplifier or the antenna posts of conventional television receivers.

**UHF Tuner.** This tuner comprises a high-pass input filter with cutoff at 500 mc, r-f amplifier, mixer-oscillator, i-f amplifier (132 to 138 mc) and fixed-tuned mixer-

oscillator with low-impedance output at 21 to 27 mc. The first intermediate frequency is high enough to provide satisfactory image rejection with only two uhf tuned circuits, but is also low enough to obtain reasonable gain and noise factor with conventional tubes.

The tuner circuit diagram is given in Fig. 12. The high-pass input filter used to reduce spurious responses is shown schematically here but is illustrated in the photograph. The printed circuit is accomplished by photoengraving a 1.5-mil copper sheet bonded to a paper-base Bakelite sheet.

The 132 to 138-mc i-f amplifier, using two stages of type 6AG5 tubes with three double-tuned circuits, satisfactorily isolates the first and second oscillators. Automatic gain control is not used because the band-shape response varies markedly with varying tube transconductance.

The tuning elements illustrated in the underside of the tuner chassis comprise strips of copper foil mounted on natural paper-base Bakelite tubing with low-loss cement. Tapered copper foil is used to obtain a desirable tuning curve and proper tracking of the r-f and oscillator circuits. The oscillator element consists of a bifilar winding terminating in a split capacitor section. All three elements are tuned by means of copper or brass cores inside the Bakelite tubing.

The uhf converter (not shown) has been designed to operate into the antenna connection of a

television receiver tuned to either channel 12 or 13. The high-pass filter has a cutoff at about 475 mc. An r-f tuned circuit with proper impedance matching to maintain high operating circuit Q is used between the filter and the crystal mixer.

The i-f system comprises a low-noise high-gain cascode stage followed by a conventional pentode stage.

The Stratford-Bridgeport project, under the direction of C. B. Jolliffe, co-ordinates the facilities of RCA Laboratories, RCA Victor Division and the National Broadcasting Co. The latter unit has taken responsibility for procurement of the site, construction of building and tower, installation, operation and field investigations.

Acknowledgement is made for technical details of the equipment design used herein to C. D. Kentner, T. M. Gluyas, L. J. Wolf and O. O. Fiet.

Complete engineering data on the KC2XAK experimental station appear concurrently in the March 1950 issue of the *RCA Review*.

### REFERENCES

- (1) G. H. Brown, J. Epstein, D. W. Peterson, Comparative Propagation Measurements at 67.25, 288.510 and 910 Megacycles, *RCA Review*, p 177, June 1948.
- (2) G. H. Brown, Field Test of Ultra-High-Frequency Television in the Washington Area, *RCA Review*, p 565, Dec. 1948.
- (3) E. W. Allen, Jr., UHF Propagation Characteristics, *ELECTRONICS*, p 86, Aug. 1949.
- (4) J. Fisher, Field Test of UHF Television, *ELECTRONICS*, p 106, Sept. 1949.
- (5) L. J. Wolf, Triplex Antenna for Television and F-M, *ELECTRONICS*, p 88, July 1947.
- (6) D. W. Peterson, Notes on a Coaxial Line Bead, *Proc. IRE*, p 1294, Nov. 1949.



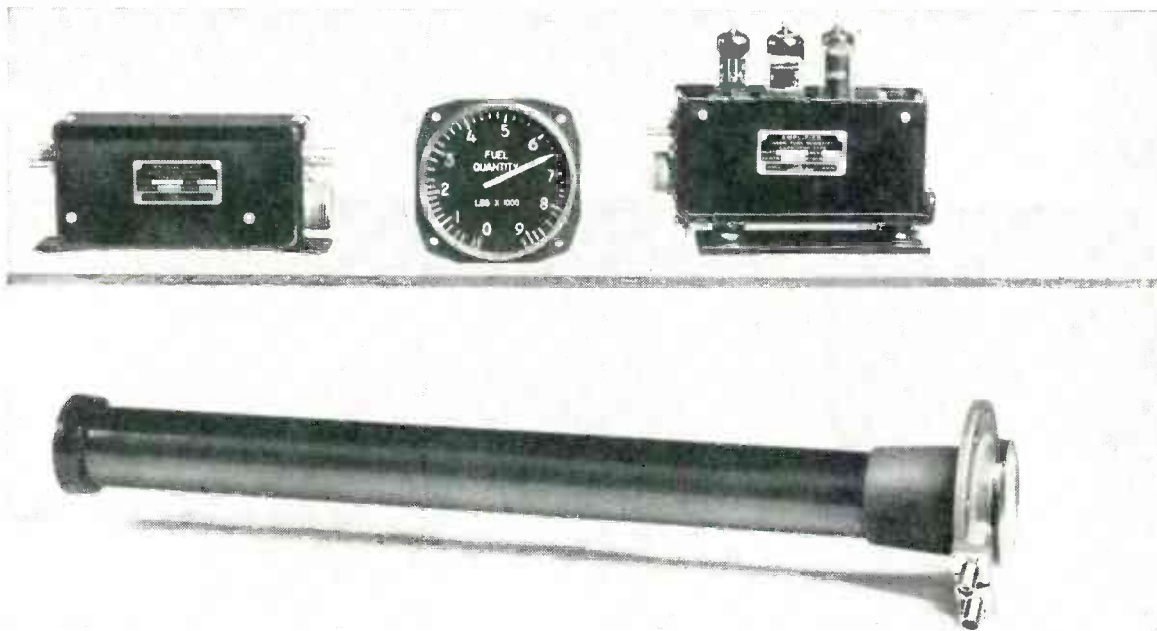

Of the four components of the fuel-gage system—bridge transformer, indicator, amplifier and tank unit—only the indicator, a rebalance motor, contains moving parts

# AIRPLANE FUEL GAGE

Laboratory accuracy is provided in a rugged instrument that indicates the weight of fuel, rather than volume. Employs self-balancing bridge principle, approved for military aircraft under AN-G-31A specifications

By **CURTISS R. SCHAFER\***

*Chief Electronics Engineer  
Aviation Engineering Corporation  
Ozone Park, New York*

**D**URING the latter part of 1942, the disadvantages of the conventional float types of gasoline gage for aircraft became apparent. This gage employed a cork or hollow metal float to measure the level of the fuel; the information was then transmitted via gears, magnets and/or selsyns to an indicating instrument on the pilot's or flight engineer's instrument panel. Serious errors resulted from gasoline slosh, the volumetric expansion of gasoline with an increase in temperature, changes in supply voltage and wear in mechanical linkages.

In the effort to obtain a better fuel quantity gage for both mili-

tary and commercial airplanes, three new types of capacitor gages were developed. All of these make use of the dielectric constant of gasoline, which varies from 1.85 to 2.3, depending on the temperature and the constituents of the gasoline.

The first type consisted of an oscillator (around 100 kc) which supplied voltage to a capacitance bridge. One arm of this bridge was a concentric tube capacitor mounted vertically in the tank; the unbalance voltage, which was proportional to

the level of the fuel, was rectified and read on a 270-degree d-c microammeter.

The second type also used an oscillator feeding a bridge with two capacitance arms, one of which again took the form of a concentric tube assembly in the fuel tank. The currents flowing through the tank unit and the reference capacitor (usually of the fixed silver-mica variety) were rectified and compared in a d-c ratiometer. An improved version of this type used an a-c ratiometer, constructed like a miniature two-phase power factor meter. This version eliminated the rectifiers and their waveform errors.

## Approved Type

The third type is based upon the self-balancing bridge principle and is now the only type approved for military aircraft under AN-G-31A specifications. In common with the

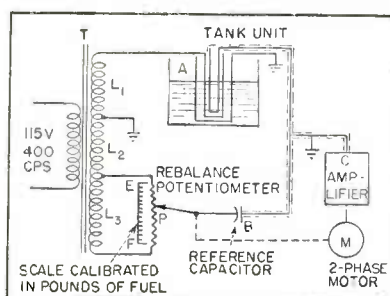

FIG. 1—Major elements of the bridge circuit

\* Now member of the technical staff, C. G. S. Laboratories, Inc., Stamford, Connecticut.

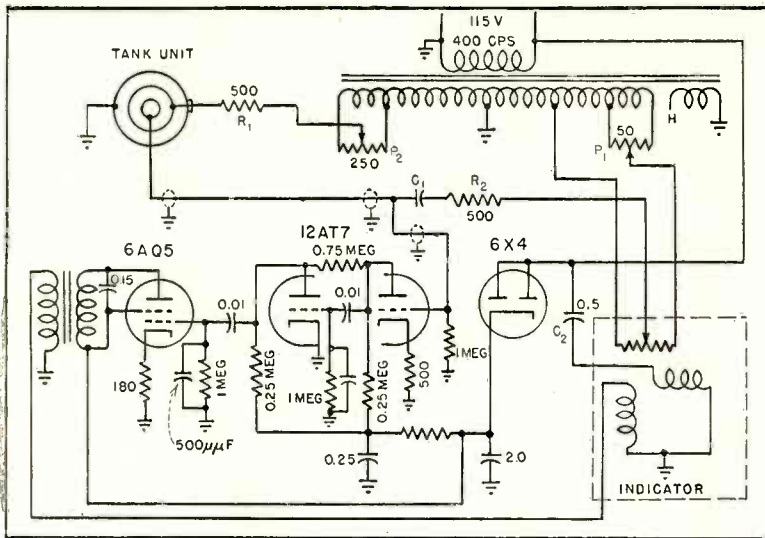

FIG. 2—Circuit of commercially available fuel gage

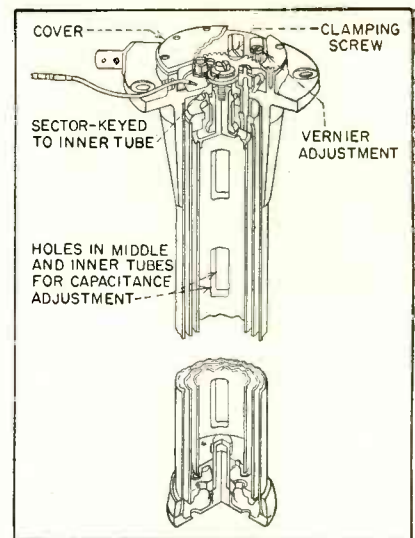

FIG. 3—Cutaway view of tank unit

other two versions of capacitance-type gages, it indicates weight of fuel rather than volume when used with AN-F-28, AN-F-32, AN-F-34 and AN-F-48 aircraft fuels. This concept of fuel quantity measurement is quite important, for engines use fuel on a weight rather than volume basis.

### Circuit Action

The basic bridge circuit is shown in Fig. 1. A concentric tube capacitor *A* is mounted vertically in a cell of the gasoline tank. When the tank is empty, and there is no gasoline in *A*, the capacitance of *A* equals that of the reference capacitor *B* (usually 75 to 550 $\mu\text{f}$  in typical installations). If the voltages across  $L_1$  and  $L_2$  are also equal, there is no unbalance voltage fed into amplifier *C*, no movement of motor *M*, and the arm of potentiometer *P* remains at the empty end of scale *E*.

If the tank cell is half full, the impedance of *A* is decreased, and the increase in voltage from  $L_1$  must be balanced out by an increase in voltage (but of the opposite phase) from  $L_2$ . This is accomplished by adding voltage from  $L_3$ , which is in phase with the voltage from  $L_2$ . This voltage is added by driving the potentiometer wiper to a position midway between *E* and *F*, which rebalances the bridge. When the tank is full, the amplifier again drives the motor to the new balance point, at *F*.

The motor *M* is a miniature two-phase instrument type, with a

salient-pole, high-resistance rotor which is designed to give maximum torque when stalled. The current for one phase is supplied by the amplifier, the current for the other by the same generator that supplies the primary of bridge transformer *T*. The phase fed by the generator is known as the line phase, or reference phase, and is fed through a capacitor so that it is normally 90 degrees out of phase with the current from the amplifier.

The current from the amplifier is always in phase with the output voltage from the bridge, but the latter may be either in phase with, or 180 degrees out of phase with, the generator voltage. Hence the direction of rotation of the motor depends upon the phase angle of the current from the amplifier. Bridge, amplifier and motor are connected so that the unbalance voltage from the bridge always drives the motor and potentiometer in the direction required to rebalance the bridge.

As the balance point is approached, the amplifier output decreases; when balance is reached, the amplifier input and output are cancelled out and the motor stops. Thus the bridge is automatically balanced. Since fuel quantity determines the position of the wiper arm on the potentiometer, a pointer may be attached to the shaft carrying the wiper arm and thus indicate pounds of fuel on an appropriate circular scale.

The schematic of a commercial model is shown in Fig. 2. Refine-

ments have been added to the basic circuit to allow for manufacturing tolerances in the values of the various components. Potentiometer  $P_1$  is used to calibrate the full-scale point;  $P_2$  is the zero or empty calibration adjustment. A 6.3-volt winding has been added to the bridge transformer to supply the heaters of the tubes in the amplifier.

Resistors  $R_1$  and  $R_2$  limit current in case of a shorted reference capacitor, tank unit or wiring. The reference capacitor  $C_1$  is represented by *B* in the basic circuit diagram. This is hermetically sealed in an HC-6/U crystal holder, and plugs into a socket in the bridge unit. The bridge transformer is supplied with 115-volt, 400-cycle, single-phase current; the amplifier and indicator must also be supplied from the same current source to maintain proper phase relationships in the system.

### Tank Unit

The tank unit (*A* on the diagram of the basic circuit) is made of three concentric tubes of different diameters; the inner and middle tubes are insulated from each other and from the outer tube. All are assembled into a head casting which holds them rigidly together and provides a surface for mounting the entire unit in the fuel tank of the airplane. The center tube and the middle tube form the active capacitor surfaces; the outer tube is grounded and serves as electro-





# Recent Developments in

Nonmathematical analysis of present-day and possible future communications systems. Author cites feasibility of a system for transmitting the English language at speaking rate over a channel with 20-to-1 signal-to-noise ratio and a bandwidth of only 2.3 cycles per second

By **CLAUDE E. SHANNON**

*Bell Telephone Laboratories, Inc.  
Murray Hill, New Jersey*

**T**HE NEWER SYSTEMS of modulation, such as f-m, ppm (pulse position modulation), and pcm (pulse code modulation), have the interesting property that it is possible to exchange bandwidth for signal-to-noise ratio; that is, we can transmit the same information with a smaller transmitter power provided we are willing to use a larger bandwidth. Conversely, in pcm it is possible to use a smaller bandwidth at the expense of an increased signal power. The discovery of these systems has prompted a re-examination of the foundations of communication theory. A number of workers have contributed to this field, among them Gabor, Wiener, Tuller, Sullivan and the writer.

The basic ideas of communication theory are not new. Important pioneering work was done by Nyquist and Hartley in the 1920's and some of the roots can even be traced back to the nineteenth century physicist Boltzmann. The more recent developments, however, include factors that were ignored in earlier treatments; in particular, we now have a much better understanding of the effect of noise in the channel and of the importance of statistical properties of the messages to be transmitted.

In this paper the highlights of this recent work will be described with as little mathematics as possible. Since the subject is essentially a mathematical one, this necessitates a sacrifice of rigor; for more precise treatments the reader may consult the bibliography.

The type of communication system that has been most extensively investigated is shown in Fig. 1. It consists of an information source which produces the raw information or message to be transmitted, a transmitter which encodes or modulates this information into a form suitable for the channel, and the channel on which the encoded information or signal is transmitted to the receiving point. During transmission the signal may be perturbed by noise as indicated schematically by the noise source. The received signal goes to the receiver, which decodes or demodulates to recover the original message, and then to the final destination of the information.

It will be seen that this system is sufficiently general to include the majority of communication problems if the various elements are suitably interpreted. In television, for example, the information source is the scene being televised, the message is the output of the pick-up tube and the signal is the output of the transmitter.

A basic idea in communication theory is that information can be treated very much like a physical quantity such as mass or energy. The system in Fig. 1 is roughly analogous to a transportation system; for example, we can imagine a lumber mill producing lumber at a certain point and a conveyor system for transporting the lumber to a second point. In such a situation there are two important quantities, the rate  $R$  (in cubic feet per second) at which lumber is produced at the mill and the capacity  $C$  (cubic feet per second) of the conveyor. If  $R$  is greater than  $C$

it will certainly be impossible to transport the full output of the lumber mill. If  $R$  is less than or equal to  $C$ , it may or may not be possible, depending on whether the lumber can be packed efficiently in the conveyor. Suppose, however, that we allow ourselves a saw-mill at the source. Then the lumber can be cut up into small pieces in such a way as to fill out the available capacity of the conveyor with 100-percent efficiency. Naturally in this case we should provide a carpenter shop at the receiving point to glue the pieces back together in their original form before passing them on to the consumer.

If this analogy is sound, we should be able to set up a measure  $R$  in suitable units telling how much information is produced per second by a given information source, and a second measure  $C$  which determines the capacity of a channel for transmitting information. Furthermore, it should be possible, by using a suitable coding or modulation system, to transmit the information over the channel if and only if the rate of production  $R$  is not greater than the capacity  $C$ . That this is actually possible is a key result of recent research and we will indicate briefly how this is accomplished.

## Measurement of Information

Before we can consider how information is to be measured it is necessary to clarify the precise meaning of information from the point of view of the communication engineer. In general, the messages to be transmitted have meaning. This, however, is quite irrelevant to



# Communication Theory

the problem of transmitting the information. It is as difficult (more so, in fact) to transmit a series of nonsense syllables as straight English text. A little thought on the subject will convince one that the significant aspect of information from the transmission standpoint is the fact that one particular message is chosen from a set of possible messages. The thing that must be transmitted is a specification of the particular message which was chosen by the information source. If and only if such an unambiguous specification is transmitted, the original message can be reconstructed at the receiving point. Thus information in our sense must be correlated with the notion of a choice from a set of possibilities.

The simplest type of choice is a choice from two possibilities, each with probability  $\frac{1}{2}$ . This is the situation, for example, when one tosses a coin which is equally likely to come up heads or tails. It is convenient to use the amount of information produced by such a choice as the basic unit, called a binary digit or, more briefly, a bit. The choice involved with one bit of information can be indicated schematically as in Fig. 2A. At point *b* we may choose either the upper or lower line with probability  $\frac{1}{2}$  for each possibility. If there are *N* possibilities, all equally likely, the amount of information is given by  $\log_2 N$ . The reason for this can be seen from Fig. 2B, where we have eight possibilities each with probability  $\frac{1}{8}$ . The choice can be imagined to occur in three stages, each involving one bit. The first bit corresponds to a choice of either the first four or the second four of the eight possibilities, the second bit corresponds to the first or second pair of the four chosen, and the final bit determines the first or second member of the pair. It will be seen that the number of bits required is  $\log_2 N$ , in this case  $\log_2 8$  or 3.

If the probabilities are not equal,

the formula is a little more complicated. A simple case is shown in Fig. 2C. There are four possible choices with probabilities  $\frac{1}{2}$ ,  $\frac{1}{4}$ ,  $\frac{1}{8}$  and  $\frac{1}{8}$ . This can be broken down into a sequence of binary choices as indicated. The information produced is given by  $(1 + \frac{1}{2} + \frac{1}{4})$ ; the 1 is from the first choice (at point *p*) which always occurs, the  $\frac{1}{2}$  is from the choice at point *q*, which occurs only half the time (when the lower line is chosen at point *p*), and so on. In general, by a similar decomposition, the information, when the choices have probabilities  $p_1, p_2, \dots, p_n$ , is given by:

$$H = -(p_1 \log_2 p_1 + p_2 \log_2 p_2 + \dots + p_n \log_2 p_n) \quad (1)$$

This formula, then, gives the amount of information produced by a single choice. An information source produces a message which consists of a sequence of choices, for example, the letters of printed text or the elementary words or sounds of speech. In these cases, by an application of Eq. 1, the amount of information produced per second or per symbol can be calculated. It is interesting that this information rate for printed English text is about two bits per letter, when we consider statistical

structure only out to word lengths. Long-range meaning structure may reduce this figure considerably.

## Encoding Information

The importance of the measure of information, *H*, is that it determines the saving in transmission time that is possible, by proper encoding, due to the statistics of the message source. To illustrate this, consider a language in which there are only four letters: *A, B, C* and *D*. Suppose these letters have the probabilities  $\frac{1}{2}, \frac{1}{4}, \frac{1}{8}$  and  $\frac{1}{8}$ , as in Fig. 2C.

In a long text in this language, *A* will occur half the time, *B* one-quarter of the time, and so on. Suppose we wish to encode this language into binary digits, 0 or 1. Thus we might wish to transmit on a pulse system with two types of pulse. The most direct code is the following: *A* = 00, *B* = 01, *C* = 10, *D* = 11. This code requires two binary digits per letter of message. By using the statistics, a better code can be constructed as follows: *A* = 0, *B* = 10, *C* = 110, *D* = 111. It is readily verified that the original message can be recovered from its encoded form. Furthermore, the number of binary digits used is smaller on the average. It will be,

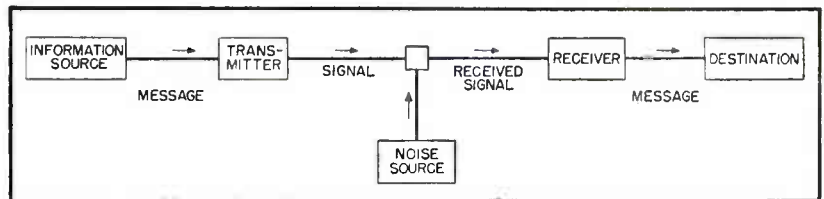

FIG. 1—Generalized communication system is roughly analogous to a transportation system

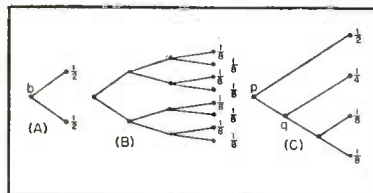

FIG. 2—Schematic representation of equal and unequal probabilities. The choice involved with one bit (binary digit) of information is comparable to tossing a coin heads or tails

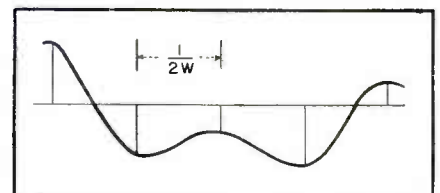

FIG. 3—Signals represented by functions of time which lie within a band of frequencies *W* cps wide can be specified by the values of a series of equally spaced samples  $1/2W$  seconds apart

in fact calculated as follows:

$$\frac{1}{2}(1) + \frac{1}{4}(2) + \frac{1}{8}(3) + \frac{1}{8}(3) = 1\frac{3}{4}$$

where the first term is due to the letter *A*, which occurs half the time and is one binary digit long, and similarly for the others. It will be noted that  $1\frac{3}{4}$  is just the value of *H* calculated for Fig. 2C.

The result we have verified for this special case holds generally. If the information rate of the message is *H* bits per letter, it is possible to encode it into binary digits using, on the average, only *H* binary digits per letter of text. There is no method of encoding which uses less than this amount.

### Capacity of a Channel

Now consider the problem of defining the capacity *C* of a channel for transmitting information. Since the rate of production for an information source has been measured in bits per second, we would naturally like to measure *C* in the same units. The question then becomes "What is the maximum number of binary digits per second that can be transmitted over a given channel?"

In some cases the answer is simple. With a teletype channel there are 32 possible symbols. Each symbol therefore represents 5 bits, provided the possible symbols are used with equal probability. If we can send *n* symbols per second, and the noise level is not high enough to introduce any errors during transmission, we can send  $5n$  bits per second.

Suppose now that the channel is defined as follows: We can use for signals any functions of time  $f(t)$  which lie within a certain band of frequencies, *W* cycles per second wide. It is known that a function of this type can be specified by giving its values at a series of equally spaced sampling points  $1/2W$  seconds apart as shown in Fig. 3. Thus we may say that such a function has  $2W$  degrees of freedom, or dimensions, per second.

If there is no noise whatever on such a channel we can distinguish an infinite number of different amplitude levels for each sample. Consequently we could, in principle, transmit an infinite number of binary digits per second, and the capacity *C* would be infinite.

Even when there is noise, if we place no limitations on the transmitter power, the capacity will be infinite, for we may still distinguish at each sample point an unlimited number of different amplitude levels. Only when noise is present and the transmitter power is limited in some way do we obtain a finite capacity *C*. The capacity depends, of course, on the statistical structure of the noise as well as the nature of the power limitation.

The simplest type of noise is white thermal noise or resistance noise. The probability distribution of amplitudes follows a Gaussian curve and the spectrum is flat with frequency over the band in question and may be assumed to be zero outside the band. This type of noise is completely specified by giving its mean square amplitude *N*, which is the power it would deliver into

a standard unit of resistance.

The simplest limitation on transmitter power is to assume that the average power delivered by the transmitter (or more precisely the mean square amplitude of the signal) is not greater than *P*. If we define our channel by these three parameters *W*, *P* and *N*, the capacity *C* can be calculated. It turns out to be

$$C = W \log_2 \frac{P + N}{N} \quad (2)$$

bits per second. It is easy to see that this formula is approximately right when  $P/N$  is large. The received signal will have a power  $P + N$  and we can distinguish something of the order of

$$\sqrt{(P + N)/N}$$

different amplitudes at each sample point. The reason for this is that the range of amplitude of the received signal is proportional to  $\sqrt{P + N}$ , while the noise introduces an uncertainty proportional to  $\sqrt{N}$ . The amount of information that can be transmitted with one sample will therefore be  $\log_2 [(P + N)/N]$ . Since there are  $2W$  independent samples per second, the capacity is given by Eq. 2. This formula has a much deeper and more precise significance than the above argument would indicate. In fact it can be shown that it is possible, by properly choosing our signal functions, to transmit  $W \log_2 [(P + N)/N]$  bits per second with as small a frequency of errors as desired. It is not possible to transmit at any higher rate with an arbitrarily small frequency of errors. This means that the capacity is a sharply defined quantity in spite of the noise.

The formula for *C* applies for all values of  $P/N$ . Even when  $P/N$  is very small, the average noise power being much greater than the average transmitter power, it is possible to transmit binary digits at the rate  $W \log_2 [(P + N)/N]$  with as small a frequency of errors as desired. In this case  $\log_2 (1 + P/N)$  is very nearly  $(P/N) \log_2 e$  or  $1.443 P/N$  and we have, approximately,  $C = 1.443 PW/N$ .

It should be emphasized that it is possible to transmit at a rate *C* over a channel only by properly encoding the information. In general

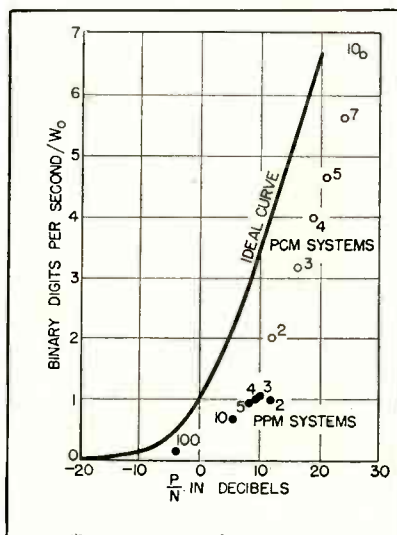

FIG. 4—Channel capacity per unit bandwidth as a function of the signal-to-noise ratio for two pulse transmission systems

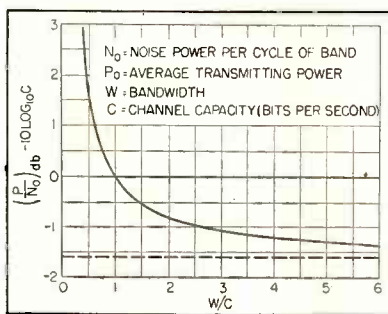

FIG. 5—Where the signal-to-noise ratio is large, halving the bandwidth roughly doubles the signal-to-noise ratio required for a given channel capacity



the rate  $C$  cannot be actually attained but only approached as a limit by using more and more complex encoding and longer and longer delays at both transmitter and receiver. In the white noise case the best encoding turns out to be such that the transmitted signals themselves have the structure of a resistance noise of power  $P$ .

### Ideal and Practical Systems

In Fig. 4 the curve is the function  $C/W = \log(1 + P/N)$  plotted against  $P/N$  measured in db. It represents, therefore, the channel capacity per unit of band with white noise. The circles and points correspond to pcm and ppm systems used to send a sequence of binary digits, adjusted to give about one error in  $10^5$  binary digits. In the pcm case the number adjacent to a point represents the number of amplitude levels; 3 for example is a ternary pcm system. In all cases positive and negative amplitudes are used. The ppm systems are quantized with a discrete set of possible positions for the pulse, the spacing is  $1/2W$  and the number adjacent to a point is the number of possible positions for a pulse.

The series of points follows a curve of the same shape as the ideal but displaced horizontally about 8 db. This means that with more involved encoding or modulation systems a gain of 8 db in power could be achieved over the systems indicated.

Unfortunately, as one attempts to approach the ideal, the transmitter and receiver required become more complicated and the delays increase. For these reasons there will be some point where an economic balance is established between the various factors. It is possible, however, that even at the present time more complex systems would be justified.

A curious fact illustrating the general misanthropic behavior of nature is that at both extremes of  $P/N$  (when we are well outside the practical range) the series of points in Fig. 4 approaches more closely the ideal curve.

The relation  $C = W \log(1 + P/N)$  can be regarded as an exchange relation between the parameters  $W$  and  $P/N$ . Keeping the

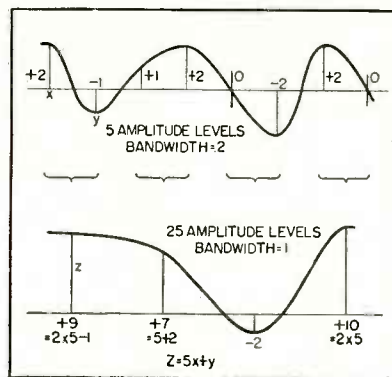

FIG. 6—Graphic representation of a typical system for conserving bandwidth at the cost of increasing transmitted power

channel capacity fixed we can decrease the bandwidth  $W$  provided we increase  $P/N$  sufficiently. Conversely, an increase in band allows a lower signal-to-noise ratio in the channel. The required  $P/N$  in db is shown in Fig. 5 as a function of the band  $W$ . It is assumed here that as we increase the band  $W$ , the noise power  $N$  increases proportionally,  $N = WN_0$ , where  $N_0$  is the noise power per cycle of band. It will be noticed that if  $P/N$  is large a reduction of band is very expensive in power. Halving the band roughly doubles the signal-to-noise ratio in db that is required.

One method of exchanging bandwidth for signal-to-noise ratio is shown in Fig. 6. The upper curve represents a signal function whose bandwidth is such that it can be specified by giving the samples shown. Each sample has five amplitude levels. The lower curve is obtained by combining pairs of samples from the first curve as shown. There are now 25 amplitude levels that must be distinguished but the samples occur only half as frequently; consequently the band is reduced by half, at the cost of doubling the signal-to-noise ratio in db. Operating this in reverse doubles the band but reduces the required signal-to-noise ratio.

To summarize, there are three essentially different ways in which bandwidth can be reduced in a system such as television or speech transmission. The first is the straightforward exchange of bandwidth for signal-to-noise ratio just discussed. The second method is utilization of the statistical correla-

tions existing in the message. This capitalizes on particular properties of the information source, and can be regarded as a type of matching of the source to the channel. Finally, particular properties of the destination can be used. Thus, in speech transmission the ear is relatively insensitive to phase distortion. Consequently, phase information is not as important as amplitude information, and need not be sent so accurately. This can be translated into a bandwidth saving, and in fact part of the reduction attained in the vocoder is due to this effect. In general, the exploitation of particular sensitivities or blindnesses in the destination requires a proper matching of the channel to the destination.

Many present-day communication systems are extremely inefficient in that they fail to make use of the statistical properties of the information source. To illustrate this, suppose we are interested in a system to transmit English speech (no music or other sounds) and the quality requirements on reproduction are only that it be intelligible as to meaning. Personal accents, inflections and the like can be lost in the process of transmission. In such a case we could, at least in principle, transmit by the following scheme. A device is constructed at the transmitter which prints the English text corresponding to the spoken words. This can be encoded into binary digits using, on the average, not more than two binary digits per letter or nine per word. Taking 100 words per minute as a reasonable rate of speaking, we obtain 15 bits per second as an estimate of the rate of producing information in English speech when intelligibility is the only fidelity requirement. From Fig. 4 this information could be transmitted over a channel with 20 db signal-to-noise ratio and a bandwidth of only 2.3 cps!

### BIBLIOGRAPHY

- R. V. L. Hartley, Transmission of Information, *B.S.T.J.*, p 535, July 1928.
- C. E. Shannon, A Mathematical Theory of Communication, *B.S.T.J.*, p 379, July 1948, and p 623, Oct. 1948.
- C. E. Shannon, Communication in the Presence of Noise, *Proc. IRE*, p 10, Jan. 1949.
- C. B. Feldman and W. R. Bennett, Bandwidth and Transmission Performance, *B.S.T.J.*, p 490, July 1949.
- D. G. Fink, Bandwidth vs Noise in Communication Systems, *ELECTRONICS*, Jan. 1948.

# PIN-POINTING ULTRASONIC ENERGY

Two watts of sound energy concentrated into an extremely fine area records on sound-sensitive paper without touching its surface. Magnetostriction oscillator, using an 805 triode, drives a nickel-alloy tube at about 20,000 kc

By **HOMER J. DANA**

*Director, Engineering Experimental Station*

and

**JAMES L. VAN METER**

*Department of Electrical Engineering*

*State College of Washington  
Pullman, Washington*

**M**AKING a permanent record on paper without touching the surface of the paper may be accomplished with an information-modulated light source focused onto a moving strip or disc of light-sensitive paper. Where it is inconvenient or impossible to incorporate a light-tight housing, or where the use of light-sensitive paper is undesirable, some other means for transferring the information to paper must be used.

## **Ultrasonic Recording**

A special kind of sono chromotropic paper offers a convenient alternative. It is chemically treated so that portions of its surface which are subjected to high-intensity ultrasonic energy undergo a visible change. Thus, a modulated source of ultrasonic energy could, if sufficiently intense, inscribe information on such paper for a permanent record, and also meet the requirement for a recording head that does not touch the surface of the paper.

This article describes an ultrasonic generator capable of pin-pointing two watts of ultrasonic energy for the purpose outlined. In use, the recorder point, which is actually the end of the vibrating

element of a magnetostriction oscillator, is mounted in a fixed vertical position slightly above the special recording paper which is continuously moved for time reference.

## **Generator Requirements**

An analysis of the problem indicated that a practical frequency for use in this work should lie within the general range of 10 to 30 kc. A study of all the methods of producing ultrasonic vibrations in air indicated that the magnetostriction oscillator has the best possibilities for focusing.

It was estimated that 2 watts of usable energy would be required at the point of focus in order to effect inscription. Under most favorable conditions, the power converted into sound energy is estimated to be only about 10 percent of the electrical energy delivered to the vibrating element of a magnetostriction oscillator. Furthermore, if this vibrating element is provided with a reflector or other device on the end for focusing the energy to a point, only a small part of the input energy, possibly 1 percent will be available at the point of focus. This condition would call for an oscillator having about 200 watts electrical input to the vibrating element.

First a small oscillator was built and its behavior was studied in order to work out the design of a

more powerful unit. Based upon this preliminary study, the design was made for a magnetostriction oscillator using an 805 triode to drive a nickel alloy tube at about 20 kc. The electrical circuit for this power unit is shown in the diagram. The principal elements include the tube, a plate coil, a grid coil and the vibrating element with its mounting.

Experiments disclosed that a 1-to-1 turns ratio between plate and grid coils gives the best results. When the grid turns exceed the plate turns by more than a 2-to-1 ratio, the grid current exceeds the rated capacity of the tube. After several trials, best results were obtained by using 666 turns of No. 25 sse wire wound with  $\frac{3}{8}$ -inch inside diameter one inch long for each of the coils.

## **The Vibrating Element**

The vibrating element consists of a thin-wall nickel alloy tube  $\frac{3}{8}$  inch in diameter and securely mounted in a rigid holder designed for the purpose. This holder grips the tube securely at its neutral point without affecting its mode of vibration. A tube was selected rather than a solid rod because of its superior heat-radiating qualities. In an oscillator of this power, heat dissipation is a serious problem, due in part to internal friction and part to

This article is based on a paper presented at the 1949 National Electronics Conference. The conference paper will appear in the *NEC Proceedings*.



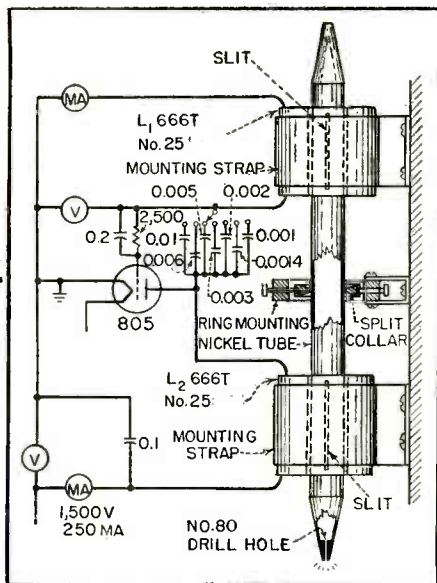

Schematic of magnetostriction oscillator with seven operating frequencies between 10 and 28 kc

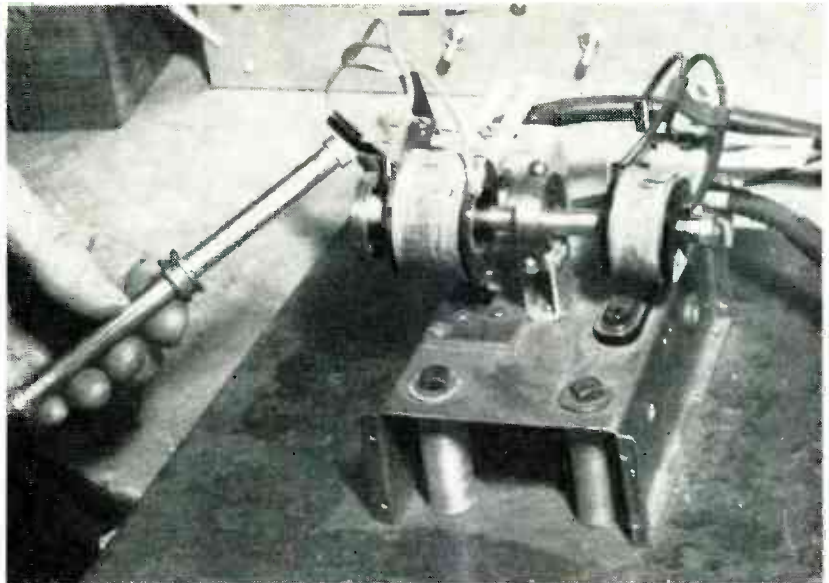

End-reflector type vibrating element that led to the discovery of the pencil-shaped tube shown in the drawing. Unmounted tube shows slits for cooling and split-collar mounting ring at center

circulating current induced in the tube by the grid and plate coils. The heating can be reduced considerably by slitting the tube, but this in turn produces a wide band of unwanted frequencies outside the fundamental. A compromise was effected by cutting a short longitudinal slit under each coil and leaving the ends of the tube intact.

When the vibrating element in a magnetostriction oscillator is magnetized by a-c it will vibrate at twice the applied frequency. This results from the fact that the rod will contract on both the positive and the negative swings of the applied a-c. To make the rod vibrate at the applied frequency, a magnetic bias is applied and this should exceed the induced magnetic field. In this oscillator the bias is supplied by the d-c in the plate coil.

The resonant frequency of the vibrating element of a magnetostriction oscillator is determined by the equation  $F = V/2L$  where  $F$  is the frequency in cps,  $V$  the velocity of sound in the material in cm per second, and  $L$  the length of the tube in centimeters.

The velocity of sound in nickel varies inversely with temperature. At 32 F it is approximately 4,973 meters per second. Therefore at this temperature the length of a plain nickel-alloy vibrating element with a natural frequency of 14 kc is 17.75 cm. When a concave piston

or reflector is attached to the end of the tube the loading results in a lowered frequency. This effect requires a shortening of the tube to raise the frequency to the desired range. For the aluminum reflectors used, the length of the tube is reduced to approximately 12.7 cm.

#### Mounting Ring

For mounting a rod used as a vibrating element, it is customary to pinch it firmly between the tips of three screws extending radially from a mounting ring. However, this method is not sufficient to secure a thin metal tube without deforming it or allowing it to slip. A special mounting was designed as shown in the drawing and photograph. This split brass collar grips the tube firmly and yet permits it to be shifted when the screws are loosened. The photograph shows the assembled driver unit and the vibrating element in its mounting. The shape of the reflectors on each end of the tube is essentially spherical.

Experiments with aluminum pistons in the end of the nickel tube revealed that they absorb an excessive amount of power owing to internal friction. Therefore a reflector was formed from sheet nickel and silver-soldered to the end of the tube. This metal did not absorb so much energy by heating, but tests revealed that the focused

energy from this reflector was not as yet adequate for the purpose intended. However, an interesting phenomenon was observed during these experiments.

A nickel tube had been prepared with a conical point, resembling a sharpened pencil. The cone was formed separately in a die and silver-soldered to the tube. When this blunt conical point was located just above the surface of a pan of water, it was noted that when the tube was oscillating, an air blast, issuing from a crack in the seam on the side of the cone impinged upon the surface of the water in the container below.

Another tube was prepared with a No. 80 hole drilled axially in the blunt point. In this cone, the air blast issued from the hole and depressed the surface of the water below. This effect was not the result of temperature-expanded air within the tube since the tube had two slits in the side. Apparently there is a pumping action that causes the tube to expel a jet of air of considerable force, resulting in a much better focusing of energy than was accomplished by other means.

The project which led to the discovery of this unique ultrasonic recording pencil was sponsored by the Office of Naval Research in an attempt to develop new types of facsimile recording paper.

# TELEVISION PRODUCTION TECHNIQUES

Ideas for cutting costs, speeding up production and improving quality of television receivers. Featured are conveyor accessories, subassembly jigs and assembly-line fixtures

By RICARDO MUNIZ

Division Manager  
Television Receiver Manufacturing Division  
Allen B. DuMont Laboratories, Inc., East Paterson, N. J.

THE LAYOUT of the Du Mont television receiver plant at East Paterson, New Jersey, was aimed at giving maximum value for the customer's television dollar, by improving the ratio of time usefully expended to the time expended on lifting, lugging, carrying, moving and transporting components, tubes, cabinets, subassemblies, work in process and finished goods. To accomplish this aim, material handling by hand labor was reduced to a minimum, a central signal system was provided and the production lines were mechanized, resulting in many worthwhile production shortcuts and quality insurance procedures.

## Conveyor Line Accessories

The 450,000 square feet of production floor space was laid out to give: (1) A continuous flow of materials from receiving to shipping; (2) minimum manual handling of material; (3) powered belt conveyor assembly lines; (4) mono-rail overhead conveyors for delivery and storage of larger components, subassemblies and chassis units in process.

**Console Tilt Table.** The spring-actuated table in Fig. 1 and 2 facil-

itates handling of heavy console television sets during final packing in shipping cartons. When incoming cabinets are unpacked, cartons are opened at the bottom. At the packing position, the carton is placed over the upright cabinet, and the filled carton is pushed off the end of the roller conveyor as in Fig. 1A. In tipping, the carton comes in contact with the roller on the tilt table; the table then tips slowly under restraint of the 100-lb spring to meet the falling carton. After the spring has returned the table to horizontal, the table is rotated 90 degrees as in Fig. 1B for sealing the flaps, then rotated another 90 degrees for tipping the carton back upright onto a skid, on an outgoing conveyor or directly on the floor as in Fig. 1C. Additional 180-degree rotation brings the table in position for the next set. With this table, one man can handle a 320-lb console.

An angle iron backstop, visible in Fig. 2, was added to the original design. As the table returns to horizontal the first time (between Fig. 1A and 1B) the carton rests against this backstop, helping the console to slide or seat itself in the carton.

Each of the gravity roller con-

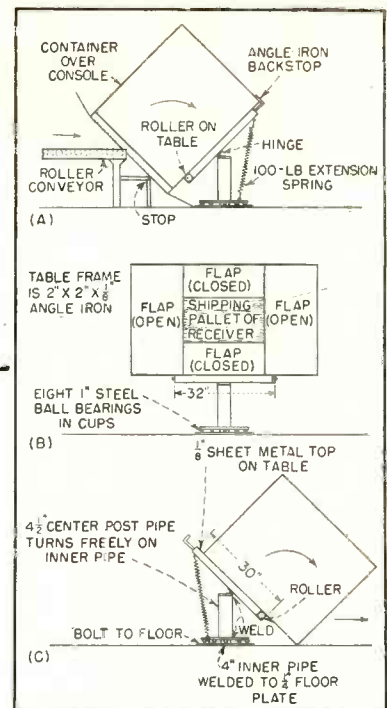
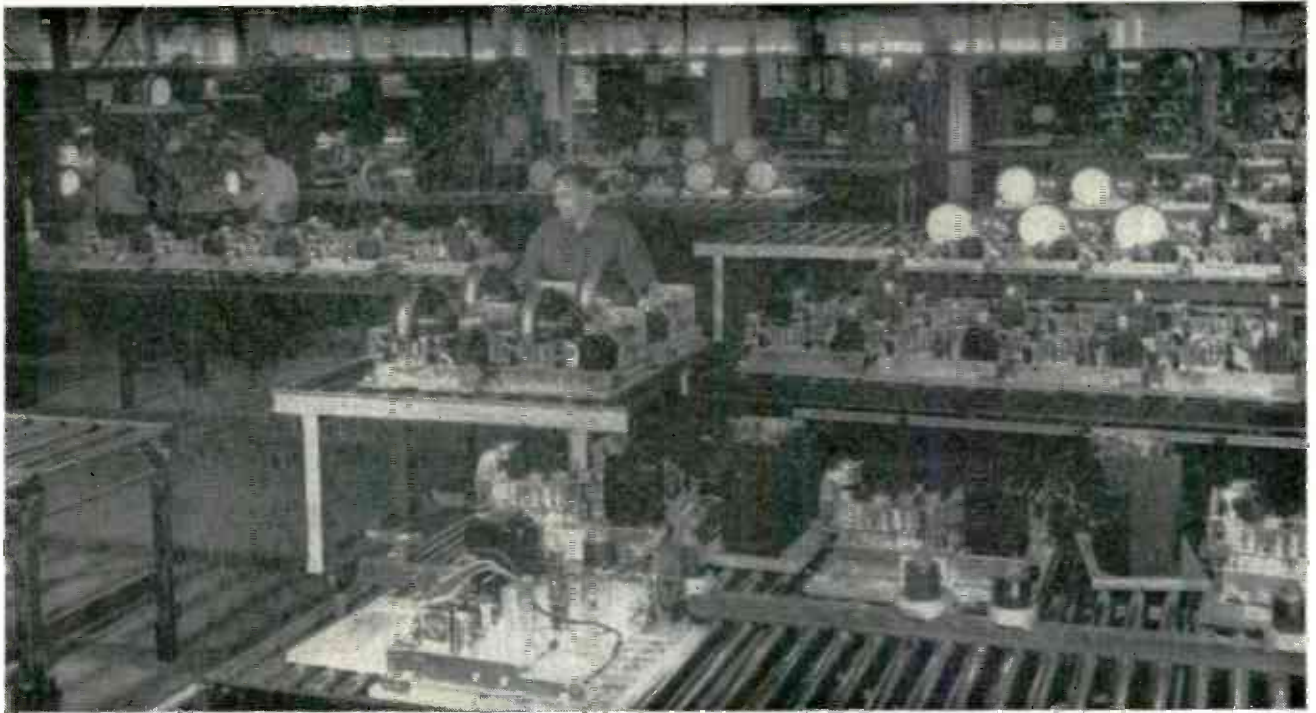

FIG. 1—Details of spring-cushioned tilt table, and three steps in its use for turning console on side and back up again without damage



FIG. 2—Tilt table in roller conveyor line enables two men or even one to turn carton with 320-lb console on side for sealing of flaps. Here carton is being turned upright again after sealing





Lifting of 60-lb chassis units is eliminated and pedestrian path is provided across roller conveyor lines by using conveyor-topped trolley cars running on floor rails across each end of television receiver aging area. For straightline transfer across gap, sets are pushed across top of car. Sets can be transferred to different lines four at a time by cart, for balancing load into the 12 aging conveyors (at right), or transferred from aging lines into the final test conveyors (at left) after their 2-hour aging at rated line voltage



FIG. 3—Strategic omission of rollers and use of angle-iron stops in roller conveyor speeds and simplifies turning over of table-model tv sets in cartons for sealing of flaps



FIG. 4—Overhead tube conveyor dips down at end of each main assembly line to make picture tubes available exactly where needed. Conveyor also brings tube clamping strip



FIG. 5—Overhead chassis conveyor moves between curved guides that hold platform steady as a chassis is slid on or off. This conveyor eliminates lifting and trucking about 40 tons a day

veyor assembly lines has adjustable leg supports to allow for a change in work height with different cabinet models. Ball caster plates at intersections and turn-around points in the lines facilitate turning of cabinets during final assembly and inspection. Live roller conveyors parallel to final assembly lines bring cartons and cases from the cabinet unpacking area, eliminating costly manpower in handling light but extremely bulky empty cartons that are used again for outgoing sets.

*Missing-Roller Technique.* In packing a table-model television set

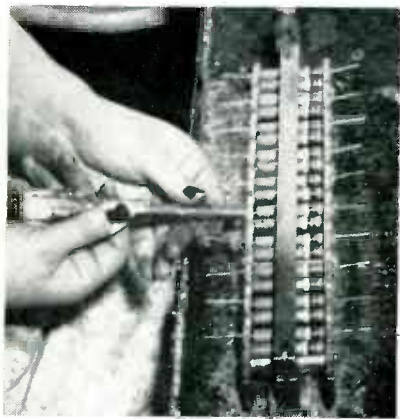

FIG. 6—Quick spin of hollow-shaft notched tool twists one lead neatly around another for paralleling of resistors. Jig holds ten pairs of resistors at a time

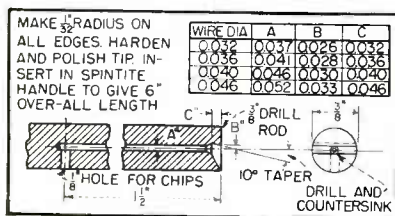

FIG. 7—Machining specifications for resistor-paralleling tool. Dimensions vary with resistor leads as per table

as it comes down a roller conveyor, the carton is placed over the upright set as shown in Fig. 3, flaps are spread out, and the carton is pushed forward until the foremost flap drops into a gap formed by leaving out some of the rollers. The set itself next drops into this gap and is turned on end with its carton. The next gap in the rollers receives the forward corners of the carton and the carton makes

another 90-degree turn, landing on its top for convenient sealing of flaps. Two more gaps produce two more 90-degree turns for the sealed carton, returning it to an upright position for conveyor delivery to the finished stock area.

### Conveyor Lines

*Overhead Chassis Conveyor.* Chassis units on which an assortment of parts have been riveted in the riveting section are suspended from a hook on the overhead chassis conveyor by the last riveting operator and are delivered to the start of the main receiver

430 feet of moving belt surface. Metal-top tables 20 feet long accommodate all mechanical assembly operations at the beginning of the lines, and similar tables 14 feet long at the ends of the lines provide facilities for tube mounting. Total length of an assembly line is thus 464 feet. All wiring operations are done on these belts progressively; through control of belt speed the movement of the chassis is made to coincide with the prearranged time cycles set by the methods section for assembly operations, reducing the operator holdups common to push-along systems and producing a saving in move time over the push-along schemes.

*Overhead Tube Conveyor.* A 584-foot-long monorail overhead conveyor with picture-tube carriers spaced four feet apart provides a safe storage capacity for 146 picture tubes in otherwise unused space near the ceiling, eliminates the need for unpacking the tubes at assembly-line positions, and eliminates the empty-carton disposal problem. Tubes are unpacked and cartons disposed of at the receiving well where the conveyor is loaded, without using trucking facilities of any kind inside the plant.

As shown in Fig. 4, tube carriers are designed to hold any size of tube from 12 to 20 inches in diameter. The conveyor dips down over each of the three main assembly lines at the picture-tube installation point. Sizes of tubes loaded are in the same ratio as total requirements of the different lines, so an operator never has to wait more than a few seconds for the desired size of tube to come along. A separate hanger over the picture tube carrier brings the corresponding clamping strip for the tube.

*Overhead Chassis Conveyors.* Two overhead conveyors of the type shown in Fig. 5 convey finished chassis units from one part of the plant to the other. One moves units from the assembly lines to the test section. The other transfers the aligned and tested units to the cabinet assembly lines. At each loading and take-off point, chassis carriers move between a metal loading table and a backstop that permits sliding a chassis on without having the carrier swing away. Each

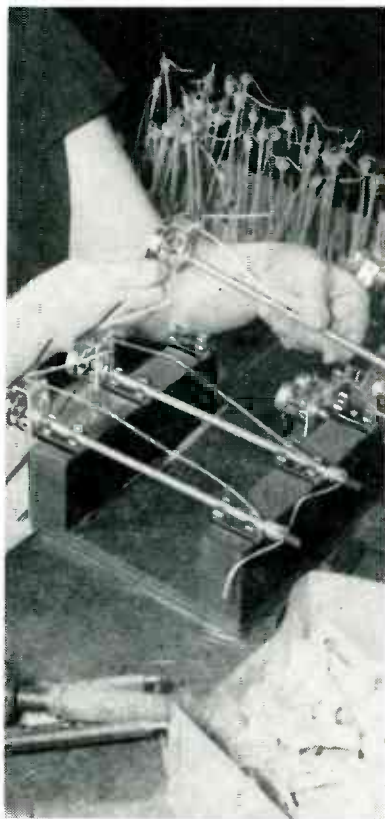

FIG. 8—Inexpensive standard fuse clips are ideal holding jigs for potentiometer subassemblies

assembly lines, thus avoiding aisle trucking and providing overhead delivery and storage. The conveyor is the conventional I-beam monorail chain and roller type, 736 feet long. It dips three times along its route, to supply each of the three main assembly lines.

*Main Assembly Line Conveyors.* Each of the three main assembly lines is a belt-on-roller type conveyor 18 inches wide and providing





FIG. 9—Universal gage for precutting capacitor and resistor leads to prescribed lengths

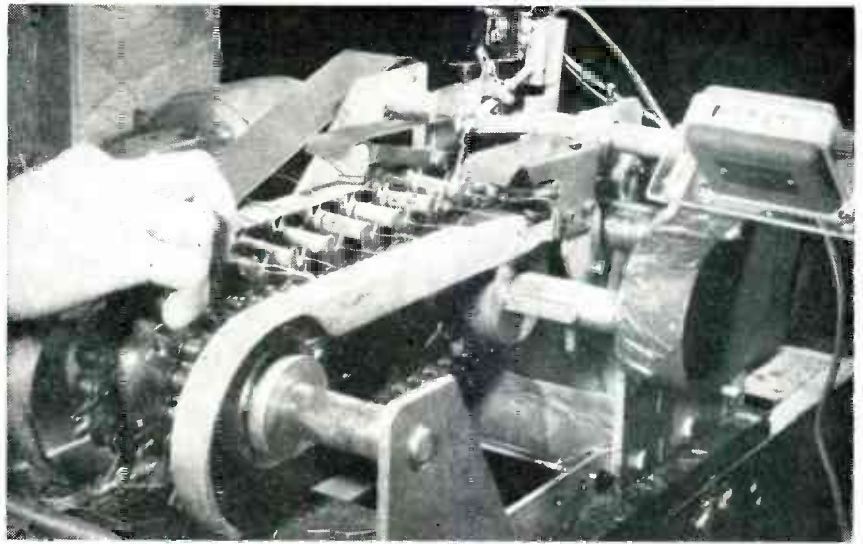

FIG. 10—Automatic machine developed by DuMont engineers for precutting leads of components at high speed. Motor-driven chopping blades function in a manner similar to the operation of pruning shears

chassis weighs approximately 60 pounds, and would be more costly to transport manually by lifting, loading, trucking and unloading.

### Subassembly Jigs

**Twisting Tool.** Use and construction of a simple tool for twisting together the paired leads of parallel-connected resistors or capacitors are shown in Fig. 6 and 7.

**Clamping Jig.** The fuse clips shown in Fig. 8 are inexpensive time-saving fixtures for holding long-shaft potentiometers securely while permitting 360-degree rotation during subassembly work.

**Lead-Cutting Gage.** The simple stepped metal plate of Fig. 9 enables an operator to cut resistor or capacitor leads quickly and accurately to any desired length before assembly. The lead length produced is stamped alongside each notch on the  $\frac{1}{8}$ -inch thick steel plate.

**Lead-Cutting Machine.** High-speed precutting of capacitor or resistor leads is made possible by the specially designed machine shown in Fig. 10. A counter indicates total output for each run of parts.

### Assembly Line Fixture

**Easel Stands.** Figures 11 and 12 show a simple and sturdy stand for holding cartons of small parts alongside main assembly lines.

**Chicken-Feeder Supply Boxes.** Resistors, capacitors, lengths of spaghetti, precut leads and any

other small components used on assembly lines are conveniently stored in the welded metal boxes shown in Fig. 13 and 14. As operators take parts from the lower opening, more drop down. Loading

is conveniently from the top, and each box holds a reasonably adequate supply.

**Test Bench.** The simple and sturdy all-welded bench design of Fig. 15 and 16 lends itself to eco-

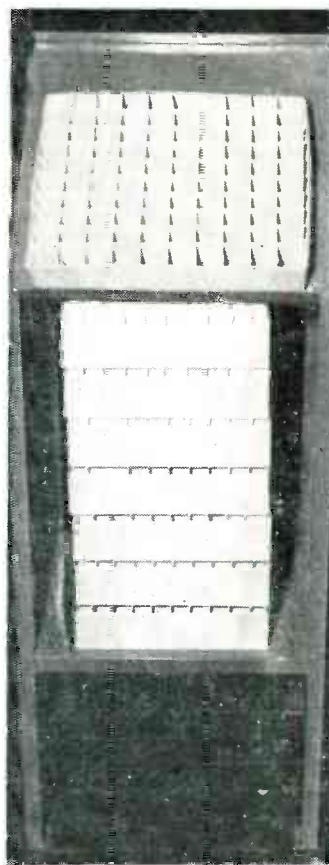

FIG. 11—Universal welded-metal table for holding and storing cartons of small parts

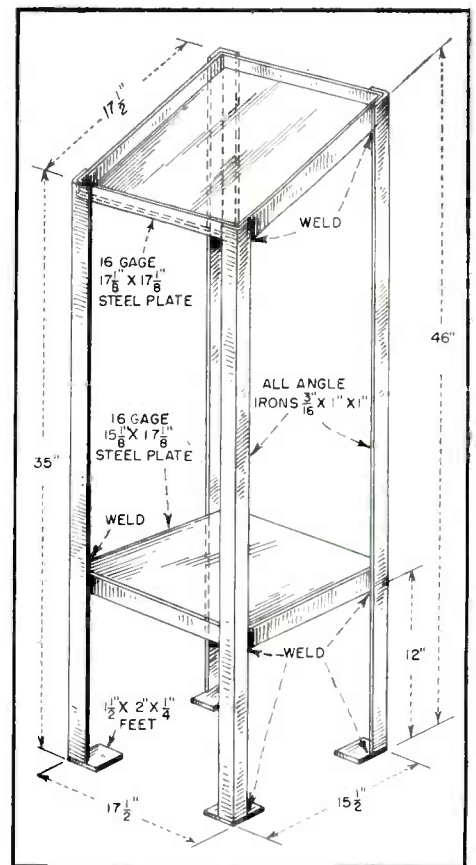

FIG. 12—Fabricating specifications for carton-holding easel. Rough edges of welds are filed or ground off and top corners are rounded off

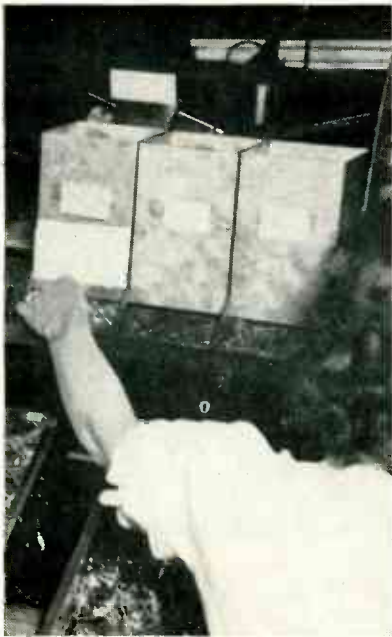

FIG. 13—Chicken-feeder type supply boxes make small parts readily accessible on main moving-belt assembly lines

nomical fabrication in quantity, provides maximum versatility for use at various television receiver test, alignment and repair positions and is both comfortable and convenient for technicians using it.

A powered metal-slat conveyor brings chassis units to and from test benches on either side. Conveyor height is such as to permit sliding a chassis directly onto the bench.

*Picture Tube Holder.* Also appearing in Fig. 16 is a standard cathode-ray tube housing developed for bench use and capable of holding either 15-inch or 19-inch tubes. The housing is steel and the face plate is Lucite. Use of a separate picture tube at repair benches simplifies working on the bottom of a chassis during trouble-shooting.

### Component Test Sets

*Flux Leakage Search Coil.* With the setup of Fig. 17 in the component acceptance section of the plant, it is a simple matter to determine whether the stray magnetic field of a new power transformer is sufficient to modulate the picture objectionably by acting on the electron beam in the neck of the c-r tube.

An unshielded 3,000-turn pickup coil is mounted on a special jig that permits placing the coil at the exact

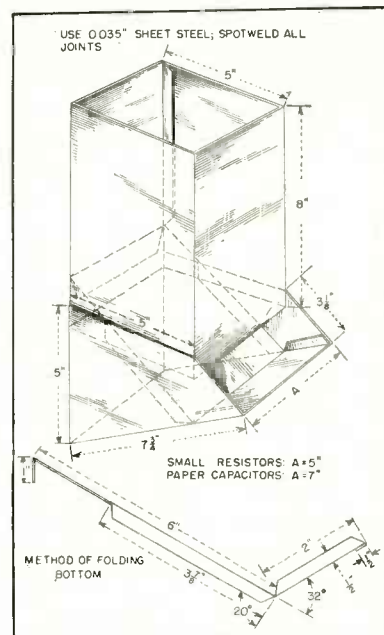

FIG. 14—Metal-shop guide for cutting and welding feed bins for small parts. For longer parts, width is increased

center line occupied by the electron gun and moving it forward or backward along this line. In addition, the jig permits rotating the coil in all three dimensions to find the point of maximum pickup. The voltage picked up by the coil is measured and its waveform viewed with a cathode-ray oscilloscope used in conjunction with a voltage calibrator (on top of scope in photo).

By using on the test chassis in turn a number of transformers exhibiting known and different external field effects in receivers, it was determined that about 0.4 volt induced in the pickup coil by the external field of a power transformer may be considered just barely passable. This voltage produces about a  $\frac{1}{8}$  inch deflection of the picture. All measurements are made with the line voltage set at its upper limit of 129 volts. The search coil technique provides a means of measuring the strengths of the external field at the crt gun position irrespective of the size or shape of the transformer being considered for acceptance.

When all available transformers exceed the leakage requirement at the distance predetermined by chassis layout, copper banding may often be used around the outside of the transformer to reduce the stray

fields at their source. A banded transformer appears disassembled on the bench in Fig. 17.

*Cold-Cathode Lighting.* Production lines are illuminated as shown in Fig. 18. Though cold-cathode lighting equipment is more expensive initially, it gives lower lamp replacement costs and provides a more uniform intensity of lighting as the tubes do not blacken with age.

### Quality in Quantity

There is, of course, much more to a successful quality production job than a fine building, miles of conveyors and various production aids. Engineering prototypes of new models are reviewed by manufacturing and receiver quality control departments, who recommend changes to improve quality and simplify manufacturing operations. Samples of the components on the bill of materials are brought in and given a rigorous test against engineering specifications by the component acceptance section of the receiver quality control department. Only parts approved may be purchased.

Individual operations on the production line are planned after exhaustive motion and time studies have been made on production prototypes of the new model constructed by the manufacturing methods section from the final bill of materials and engineering drawings.

A substantial pilot run is made to reveal any deficiencies in the methods breakdown, to train personnel, and to give manufacturing, engineering and receiver quality control departments an additional opportunity to eliminate bugs in the receiver. Complete type tests are made of each unit of the pilot run by the quality control section of the receiver quality control department.

Field test runs are made on a fully equipped mobile laboratory test bus and as a result, additional minor changes may be recommended. The bus is later used to field-check pilot run and production models. A hinged antenna mast on the roof can be raised by one man.

The cabinet engineering and receiver quality control departments



conduct tumbling and drop tests on a few packaged teletes of each model. After careful observations of any resultant damage to the cabinet or teaset components, changes in packaging or teaset construction are recommended to correct any weaknesses which may have been revealed.

The use of any components and materials for pilot or production runs must await approval of these materials by the incoming inspection section, as must the payment of invoices to vendors. Statistical quality control techniques are used to assure high quality in a most economical manner. Representative samples are selected from each shipment in accordance with scientifically prepared sampling plans; lots which fail to pass the sampling plan are returned to the vendor or inspected 100 percent. It is estimated that the use of scientific sampling inspection has reduced incoming inspection labor between 70 and 90 percent while giving a far better control of quality than haphazard sampling.

The subassembly section of the manufacturing department prefabricates about 50 percent of the material which goes into the completed teaset. These subassemblies are subjected to a scientific sampling inspection before being passed on the main assembly lines, where they are wired and soldered into the chassis as the set moves.

At frequent intervals along the main assembly line, a checker-repair operation is done. Defects found by these checkers are immediately reflected back to the responsible line operator. At the end of each production line, there is a 100-percent inspection by the process inspection section. The results are marked on an inspection sheet, and are plotted on a control chart which is posted and published. Defects are tagged by these inspectors, repaired by manufacturing, and re-inspected before being put on the overhead platform conveyor which carries the set to the test section. In addition, scientific sampling inspection is made by the product control section before completed

chassis units go to test, as a check on the main line assembly and inspection positions. This data again is plotted on control charts which are posted and published.

The teaset test section utilizes standard signals, delivered from the central signal generating room via distribution amplifiers located at various strategic places on the main floor. This central room is air-conditioned, and contains over a quarter of a million dollars of special equipment designed and fabricated by the test equipment design section.

Chassis units entering test first go to the pretest subsection, where they have power applied for the first time and are checked to be sure that each stage is operative and every control functions. Errors are corrected by trouble-shooters and repairmen. From pretest, the chassis is carried on a power-driven slat conveyor to the alignment subsection. Here each is adjusted and aligned by scope, using the signals piped from central.

After alignment, the slat con-

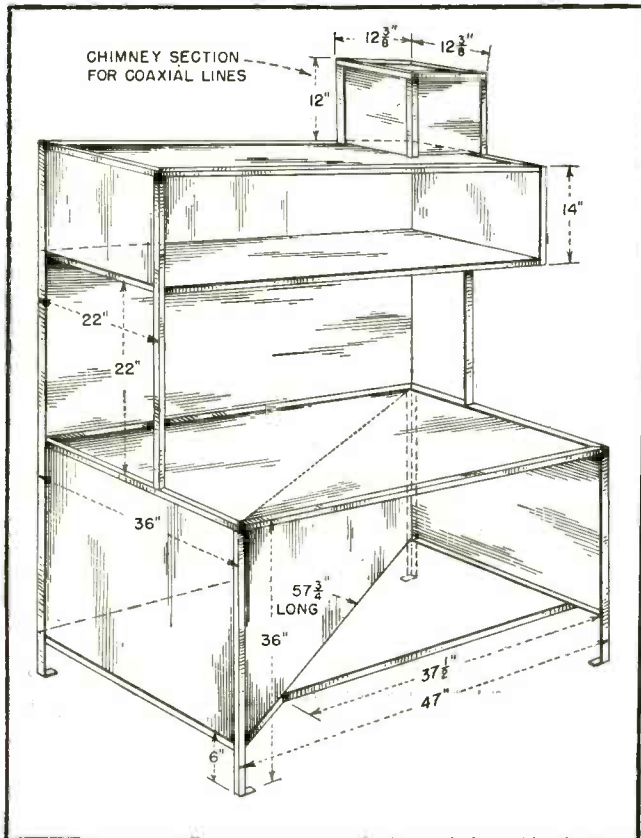

FIG. 15—Standard test bench used throughout DuMont plant. Diagonal panel underneath stiffens entire structure and protects coaxial terminations at left side of bench



FIG. 16—Top of bench can be either sheet metal or plywood. The combination Lucite-metal holding fixture takes both 15-inch and 19-inch tubes



FIG. 17—Chassis fixture for measuring stray magnetic field of power transformers at neck position of picture tube as part of power transformer acceptance test

veyor delivers the chassis to the aging area where it is run for at least two hours to bring out any latent defects. From aging, the chassis moves to the final phasing position where such defects as may have developed are corrected, and a final tailoring of the alignment is given to insure optimum performance. Each day a number of production chassis units are taken after the final phasing operation to a complete type test laboratory for electrical performance measurement.

From the phasing position, the chassis moves on an overhead platform conveyor to the final cabinet assembly section. At the beginning of each cabinet assembly line, a 100-percent cabinet inspection is performed and any necessary touchup operations are made. The cabinets move on the roller conveyor to the final assembly positions, where the chassis, loudspeaker, changer and hardware are mounted on the cabinet. Each completely assembled receiver is thoroughly checked by the final acceptance inspection section of the receiver quality control department with inside audio wobulator and video monoscope test signals. Any which fail are trouble-shot and repaired in the next line position and then reinspected. After the teletest has been ap-

proved, final cabinet inspection is made, minor cabinet scratches that may occur on the line are touched

up, and the receiver is packed and is then ready for shipment to the consumer.

Each day four or five sets of each cabinet model are moved from finished stock into the life test laboratory where each one is given a complete consumer's acceptance test. Accelerated life tests are then given at 129 line volts. The receivers are automatically turned on and off each fifteen minutes for a period as low as 16 hours for some receivers and 250 hours for others of each type. After this life run, another inspection and additional electrical measurements are made. A limited number of receivers are tested on the vibration table and in the heat and humidity chambers as a double check on production. A random selection of receivers is hauled out of finished stock and examined by Dr. Du Mont in his own personal laboratory at Cedar Grove, New Jersey, each week.

The overall philosophy is that it is more economical to make something right than to fix it.

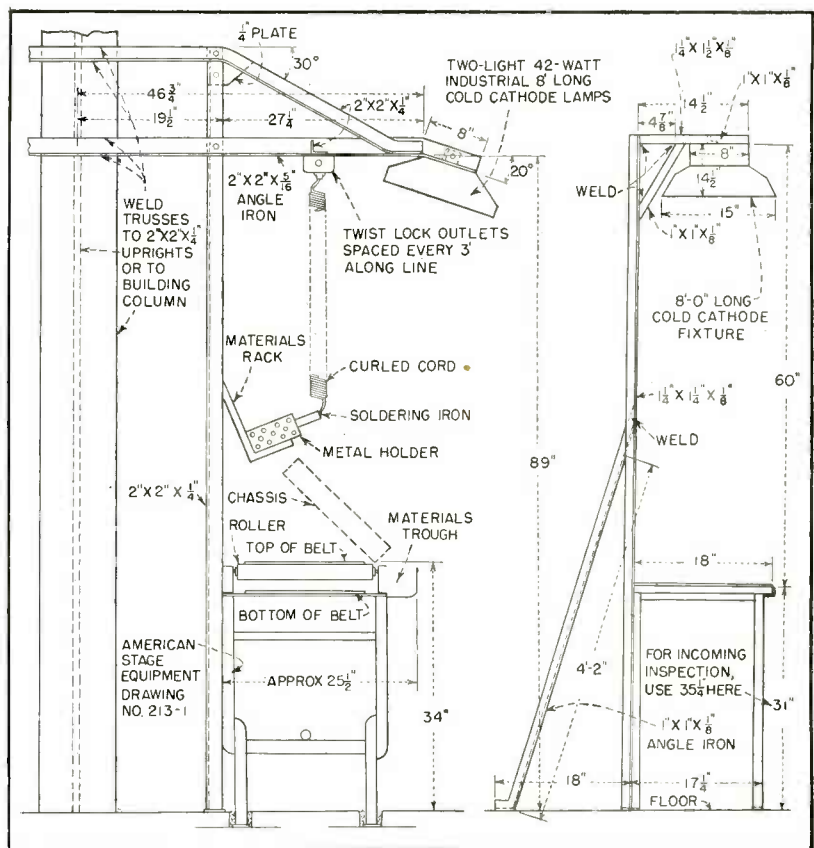

FIG. 18—Cross-sections of main moving-belt assembly line and stationary sub-assembly or incoming inspection lines, with critical dimensions for optimum positioning of overhead cold-cathode fluorescent lights. Lines are usually back to back on common center supports



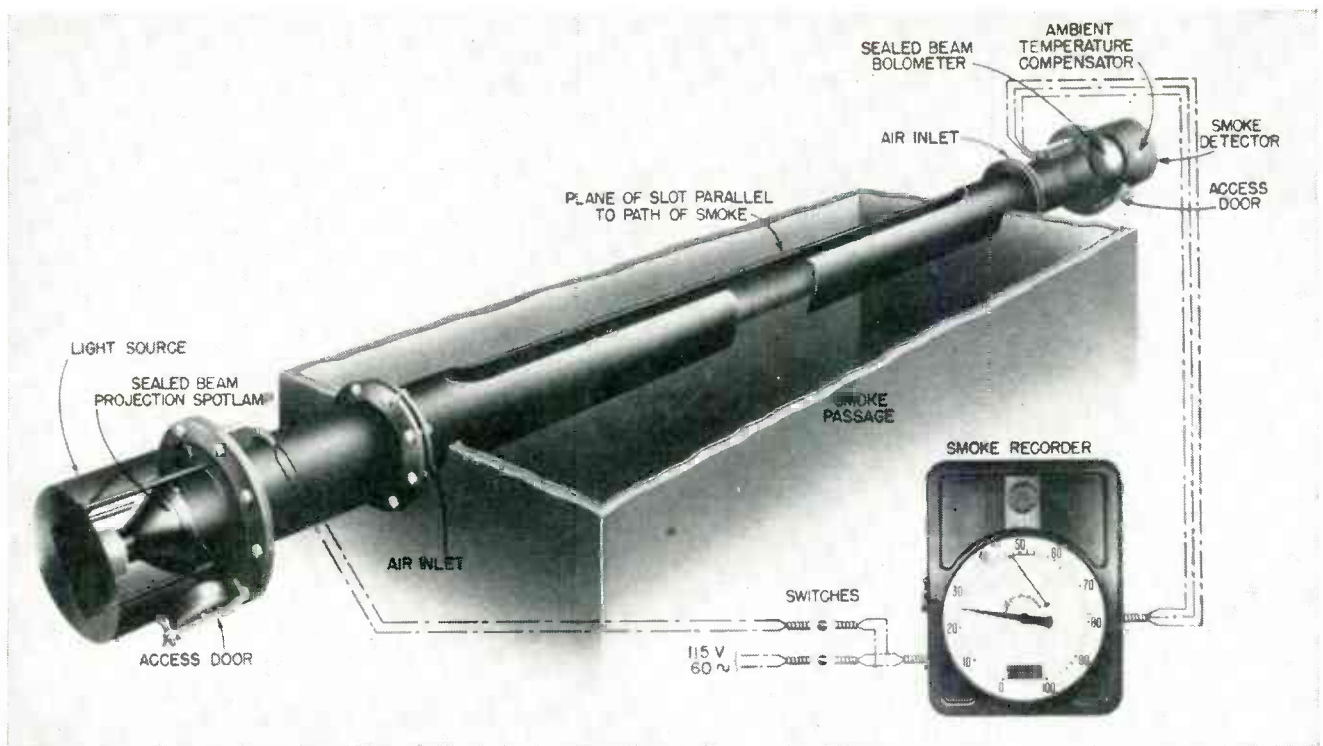

FIG. 1—Smoke in flue reduces amount of light reaching bolometer, at right, from light source at left. Resulting variations in voltage drop across bolometer, due to its changing resistance, are automatically balanced against voltage drop across portion of motor-driven slidewire unit that actuates recorder. Scale around circular chart of recorder indicates percent smoke

# Measuring Smoke Density

New sealed-beam bolometer system gives high accuracy, without need for frequent cleaning and recalibration. Lenses, mirrors, lamp and bolometric light detector are sealed in glass, and windows are washed by air. Unique circuit uses null-balance a-c potentiometer

ONE OF THE greatest obstacles to accurate measurement of smoke is the nature of smoke itself. It coats lenses and lamps of light detectors, resulting in loss of accuracy and high maintenance costs.

Dust, fly ash and fog caused by condensation of water vapor in the flue gases contribute further to inaccuracy. Where samples are drawn from the stack or breeching into bypass lines, fly ash and cinders in the smoke tend to cause clogging and result in inefficient, expensive operation.

Often smoke-density measuring

By **P. S. DICKEY**

*Vice-President  
Bailey Meter Co.  
Cleveland, Ohio*

devices must be installed in places where high ambient temperatures are common. This creates a problem for devices having receivers which depend on filament temperatures as an indication of density. Theoretically, the filament temperature depends on the amount of radiation reaching it through a

column of smoke, but if the surrounding air becomes too hot, inaccuracy will result. In addition, excessive heat may cause rapid deterioration of radiation receivers such as phototubes and self-generating photocells, resulting in frequent replacements.

Moving the smoke detector to a cooler location solves the high-temperature problem but introduces another serious one caused by lower temperatures. In cooler parts of a stack there is a great deal of condensation. Inadequately protected instruments are quickly af-

ected by the excessive moisture, and severe corrosion results due to presence of sulphur in the flue gases.

In many cases, where the light source and light-sensitive elements are attached directly to a steel smoke stack or breeching serving boiler furnaces, warping creates a serious alignment problem. Any warping or moving of the supporting breeching due to gas temperature changes will result in the light beam being deflected away from the receiving element. This leads to errors or may cause the instrument to cease functioning altogether.

Unless voltage regulators or equivalent compensators are used, phototube-operated smoke-density instruments are subject to large errors when the line voltage fluctuates to any extent. Voltage variations affect the light source and the calibrating equipment as well as the photoelectric amplifier.

### Smoke Density Methods

An early method of estimating smoke density, still employed today, is the use of Ringleman charts. Cross-hatched charts having known percentages of their area left transparent are held in the line of vision to the column of smoke. The number of the chart which most nearly matches the smoke is then assigned as an index of smoke density. Naturally this method is greatly limited by sky and wind conditions as well as human errors in judgment. An overcast sky introduces errors which become worse when high winds are present to dissipate the column of smoke as it leaves the stack. The color of particles leaving the stack leads to further errors. The closer it approaches the color of the background sky, the more difficult accurate smoke detection becomes.

A device which has done much to eliminate the guesswork from smoke-density measurement is the bolometer type instrument shown in Fig. 1. It consists of a light source and light detector (bolometer), both of sealed-beam construction, mounted at opposite ends of a length of 4-inch standard pipe. The pipe is inserted across the full

width of a smoke stack or duct. It has a longitudinal slot 3 inches wide in the center to provide a passage through which smoke flows. The smoke intercepts a beam of light projected from the light source toward the bolometer. At low densities of smoke the bolometer receives all the radiation from the light source. As smoke increases, the radiation received by the bolometer decreases. These changes in radiation are transmitted to a smoke-density recorder of the electronic type.

### Advantages of Bolometer

One reason for the decision to use a bolometer as a smoke-density measuring device is illustrated in Fig. 2. The low efficiency of the thermal resistance-sensitive element of Fig. 2A, open to the atmosphere and without concentration of incident radiation, is obvious. In Fig. 2B the radiation has been concentrated on the sensitive element through a converging lens. Since the lens involves two open surfaces it creates a serious problem of low efficiency due to dirt and dust accumulation.

Reflection of many metals such as silver and aluminum is high in the infra-red region. Advantage may be taken of this property by using an aluminized parabolic reflector as in Fig. 2C to concentrate radiation. In smoke-density measurement, however, this arrangement with its open metallic surface is subject to corrosion by oxygen or sulphur dioxide.

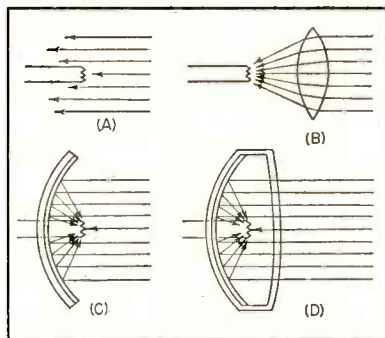

FIG. 2—Development of sealed-beam bolometer, showing how parabolic mirror (C) gives same concentrating effect as a lens (B). Final sealed unit (D) has no converging lens

In the arrangement finally adopted, shown in Fig. 2D, the radiation-sensitive element and the metallic reflector are covered with a glass lens and enclosed in a vacuum. The evacuated region not only protects the metallic surface but also increases the sensitivity of the element by eliminating heat losses due to convection and conduction.

### Null Balance Circuit

A unique bolometer circuit, shown in Fig. 3, employs an a-c potentiometer which operates on the null-balance principle. The voltage drop across the bolometer receiver is balanced against a reference voltage applied to the slide-wire.

To insure greater accuracy, a common source of 115-volt 60-cycle power feeds the light source, the smoke detector, and the measuring circuit. The light source, a 150-watt commercial spotlight, is connected in series with a 10-ohm resistor to reduce filament voltage and insure long life. The smoke detector and measuring circuit are supplied with a potential of 7.5 volts through the power transformer. This potential is stepped down further by the isolating transformer to supply the reference voltage across the slidewire.

The beam from the light source is focused on the bolometer filament which is responsive to the total radiation reaching it. The temperature, and thus the resistance of the filament, varies with the radiation received. The amount of light reaching the bolometer is a function of smoke density. Therefore, the temperature of the bolometer filament as well as its resistance and the voltage drop which occurs across the bolometer are likewise functions of smoke density.

The voltage drop across the bolometer is automatically balanced against the voltage drop across the upper portion of the slidewire by the action of an electronic amplifier and motor control. The motor control is always energized and drives the motor continuously, repositioning the slidewire and recorder until the balance point is reached.



The instrument can be calibrated easily for any desired range of smoke density with the null adjustment and range adjustment shown in Fig. 3. The null adjustment establishes the maximum smoke density to be measured. At this point the voltage drop across the bolometer is at its minimum and therefore the balancing voltage also must be at its low point. In other words, it is at the point where the density of smoke has become great enough to reduce radiation reaching the bolometer to a minimum. To achieve balance the null adjustment is moved until the recorder balances at a reading of 100 percent and the slidewire is at the upper end of its travel. Since 100 percent smoke is not normally achieved, the actual procedure involves turning off the lamp to simulate this condition.

### Adjustments

The range adjustment establishes the minimum smoke density (usually a clear stack) which will be measured. At this point full radiation from the light is reaching the bolometer and the voltage drop across the bolometer is at its maximum. The balancing voltage drop must also be at its maximum, meaning that the slidewire contact will be at the lower (0 percent smoke) end of its travel. Therefore, to set the point of minimum density at 0 percent, the range adjustment is moved until the recorder balances at a reading of 0 percent smoke. This last adjustment will in no way affect the setting of the null adjustment, which has been set at 100 percent. A fixed resistor is a further adjustment for the system and its value depends upon the distance between the light source and smoke detector.

The temperature-compensating filament shown in Fig. 3 is a sealed-in-glass resistor. Both it and the bolometer are located within the smoke detector housing so that the effect of ambient temperature variations is minimized.

As is quickly revealed by this rough study of the bolometer circuit diagram, it has the distinct advantage of being simple. The light source, smoke detector and the

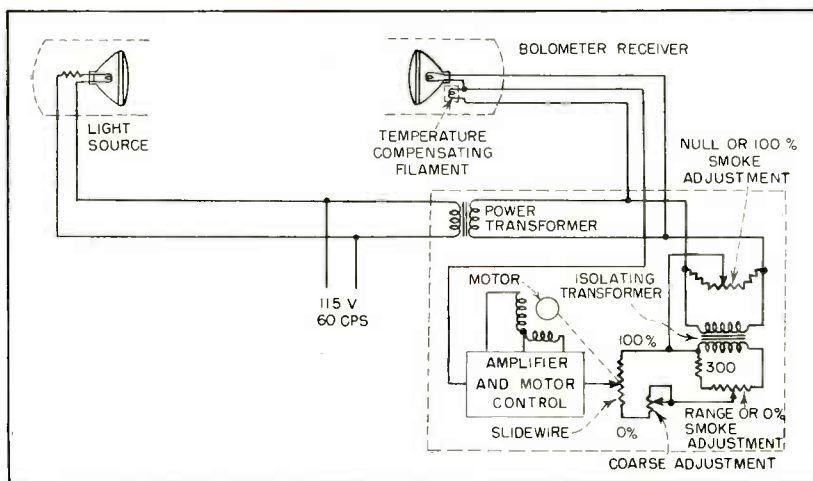

FIG. 3—Null-balance principle of Bailey bolometer-type smoke recorder

measuring circuit all are supplied with a-c power from the same source, making variations in line voltage self-compensating. No standard cell, dry cell, galvanometer, or d-c to a-c converter are needed, assuring accuracy, stability and permanence of calibration. By eliminating the galvanometer from the circuit and replacing it with an electronic amplifier, a motion-free detecting mechanism is created.

### Maintenance

Both the light source and the receiver are of the sealed-beam type and are not affected by corrosive gases or dust, thus insuring long life. The radiation-focusing mirror in the bolometer will remain clean and bright indefinitely. Instruments which are not hermetically sealed are apt to require frequent cleaning of condensing lenses and reflectors, but only the front glass on the bolometer and lamp here need attention.

Frequency of cleaning of the bolometer and lamp windows is lessened by air vents on each side of the stack, shown in Fig. 1. A negative pressure in the stack causes clean air to flow through spaced flanges which secure the light source and smoke detector to the pipe, thus preventing dust and fog from reaching the lenses. To make infrequent routine cleanings easier, access doors are provided on each housing.

Excessive smoke usually represents inefficient furnace operation and means that valuable fuel or product literally is being thrown out through the stack. To reduce smoke and insure maximum furnace efficiency, a smoke density recorder can be equipped with contacts to turn on air or steam jets or to sound alarms. For the convenience of operators, smoke density may be indicated on a 29-inch bold scale which encircles the circular recording chart. For permanent records a continuous 12-inch, 24-hour circular chart is usually provided, to give a complete picture of smoke conditions for each day and show the result of any action taken toward abatement.

Today, more than ever before, measurement of smoke density must be accurate and reliable. Smoke is now limited by rigid ordinances in many large communities, while others are considering more severe legislation in the interest of public health and civic improvement.

As integral parts of the communities in which they are located, industrial plants cannot afford to neglect the demands of local smoke abatement committees. Installation of reliable smoke density measuring devices like the bolometer-type instrument not only helps to achieve better community-industry relations, but also permits more economical furnace operation.

# Reducing Unwanted in MOBILE

Increasing occupancy of all the mobile service bands requires elimination of spurious and harmonic radiations, often beyond limits normally imposed by FCC. Suggestions are made for improved equipment design including low-pass filtering. A new technique for measuring the strength of these frequency components is described



Two-way f-m communications equipment used by Texas well-drilling outfit



New York State Police employ specially packaged transportable units

**P**HASE or frequency-modulation transmitters, consisting of a crystal oscillator followed by a phase modulator, a series of multipliers and a power amplifier, may have spurious radiations on any frequency that is an integral product of the crystal frequency. By RMA definition, spurious radiations are any r-f emissions except harmonics of the output carrier frequency radiated by or from the transmitter, other than its specified carrier frequency and modulation products. Harmonic radiations are r-f emissions radiated by or from the transmitter on multiples of its specified carrier frequency. Figure 1A shows the spectrum of a phase-modulation transmitter typical of mobile units available in 1948. The multipliers of this transmitter were two quadruplers followed by a doubler, giving a factor of 32. For the graph shown, the output frequency was 32 mc and the crystal frequency 1 mc. Therefore, there are possible spurious radiations at every integral megacycle but most are so greatly attenuated that they are not detected.

The measurable unwanted radiations consist of a spurious group near the output frequency and also the harmonics, spaced at intervals of the crystal frequency. They are also found at odd multiples of one-half the output frequency because the doubler-driver has only a single tuned-plate circuit. The reason why there is none at 80 mc is not known. Many other spurious radiations would be present here if each quadrupler were not followed by double-tuned circuits. Similar spec-



# Radiation TRANSMITTERS

By **DAVID C. PINKERTON**  
and **NEAL H. SHEPHERD**

Radio Communication Engineering  
General Electric Co.  
Syracuse, N. Y.

tra are obtained for different multiplication factors, as will later be shown.

## Improving Design

Several elementary factors govern the magnitude of the spurious radiations, and the following design features should be incorporated where they are to be minimized:

- (1) Adequate selectivity should follow each multiplier stage.
- (2) The multiplication factor for each stage should be held to a minimum.
- (3) The total multiplication factor of the transmitter should be low.
- (4) The drive on each stage should not be excessive.

Likewise, where harmonics are to be minimized, the following are important:

- (1) Adequate selectivity should follow the power amplifier.
- (2) A push-pull power amplifier will yield lower even harmonics.

Needless to say, shielding is necessary in some instances to reduce undesired coupling and direct radiation.

In order to illustrate the extent of improvement in performance attributable to each of the above design features, data are given for more recent designs. Figure 1B shows the spectrum of a transmitter directly comparable to that of Fig. 1A. The improvement is obtained by reducing the multiplication factor from 32 to 24 by changing the first multiplier from a quadrupler to a tripler, by improving the Q of the double-tuned circuits of the multipliers, by insert-

ing a double-tuned circuit between the driver and the p-a and by increasing the selectivity of the antenna tuning circuit.

Figure 1C shows the spectrum of a narrow-band 25-to-50-mc transmitter that is identical to the transmitter of Fig. 1B except that the multiplication has been reduced from 24 to 12. Here the multipliers have been changed from  $\times 3 \times 4 \times 2$  to  $\times 2 \times 3 \times 2$ . Note that only the spurious radiations near the output frequency are affected and are improved by approximately 20 db.

Figure 1D shows an additional step in improving performance by inserting a low-pass filter in the antenna cable of the transmitter of Fig. 1C. Only those spurious radiations above 37 mc are changed because the filter has negligible attenuation below that frequency. In this case all radiations are more than 90 db below the carrier.

One additional graph, Fig. 2, shows the spectrum of a 148-to-174-mc transmitter that incorporates these desirable design features to reduce all spurious and harmonic radiations to more than 85 db below the carrier.

## Using an Output Filter

The advantage of using a low-pass filter to suppress spurious and harmonic radiations at the higher frequencies rests in its negligible insertion loss, negligible effect on antenna tuning and uncritical adjustment. Several models of the GE type KY4A filter are available having design cutoff frequencies of 43, 62, 118 and 257 mc. A 1 yield

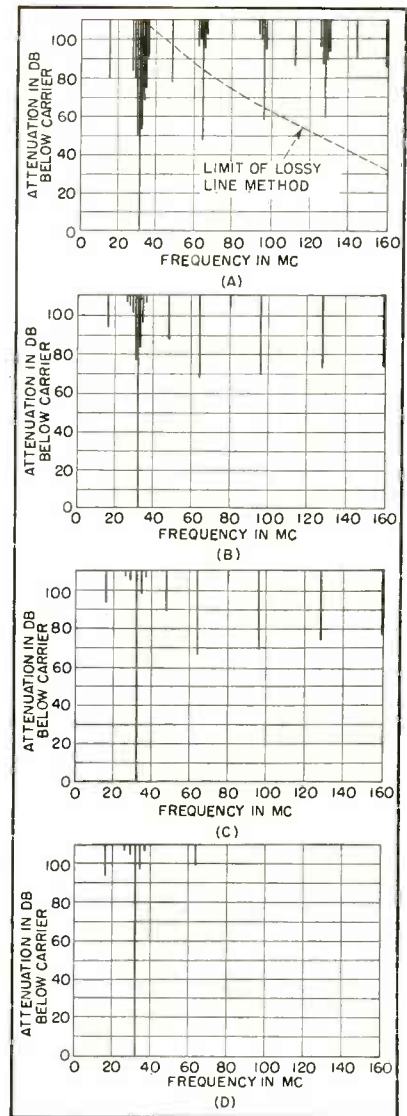

FIG. 1—Characteristics of typical transmitters for 32 mc in 1948 (A); an improved transmitter (B); spurious radiations further reduced (C); transmitter with narrow band filter (4)

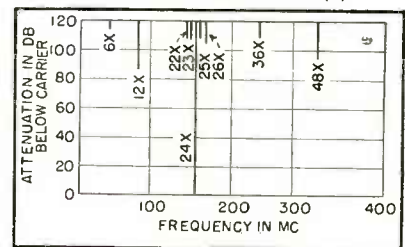

FIG. 2—Spectrum of transmitter radiation with crystal frequency X equal to 6,333.3 kc and fundamental radiation at 152 mc

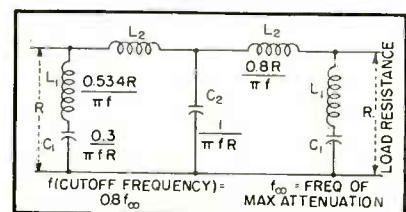

FIG. 3—Low-pass filter used to limit harmonics

## The Interference Problem

Manufacturers serving the increasingly lucrative field of mobile radio have shown commendable awareness of interference problems in which harmonics and spurious radiations are a part.

Under the most adverse operating conditions, interference may exist if the spurious radiation has a greater intensity than 125 dbw (db below 1 watt). However, design to meet this goal would be costly. Other methods, such as geographical separation, slightly different crystal frequency or multiplication factor will probably suffice for transmitters meeting the minimum FCC requirements listed below:

Maximum authorized plate power input to final r-f stage	Attenuation in db of maximum spurious or harmonic radiation
3 watts or less.....	40
Over 3 watts; including 150 watts.....	60
Over 150 watts; including 600 watts.....	70
Over 600 watts.....	80

harmonic attenuation of at least 35 db for transmitters operating in their respective bands. One of these having a cutoff of 62 mc is illustrated.

These filters consist of two  $m$ -derived sections and one constant- $k$  section. The simplified relations given on Fig. 3 may be used to calculate the values of the circuit elements for the value  $m=0.6$ .

### Conventional Measurements

Spurious radiations and harmonics are customarily determined with the transmitter loaded into its normal antenna, and the field strengths of the various frequencies measured and compared. This method has objectionable features. The results cannot be readily duplicated and do not give a figure of merit for the transmitter alone that is usable in specifying performance.

The most objectionable feature of this method is that the antenna pattern is not the same for all frequencies and thus the ratio of the spurious field strength to the carrier field strength will vary greatly with the location at which the measurements are made. Because the input impedance of the antenna varies greatly with frequency the results obtained are both a function

of the antenna design and also of the length of transmission line connecting the transmitter to the antenna.

The lossy-line method currently specified for making these measurements, although simple in theory, is not satisfactory in practice. The primary difficulty results from the fact that the attenuation of lossy line rises with frequency so that it

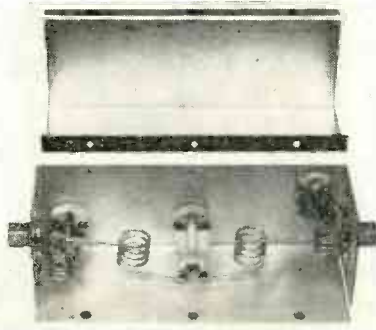

Model 4KY4A4 antenna filter used to attenuate harmonics

becomes difficult to detect harmonics at high frequencies. Suppose a length of RG-21/U lossy line is used to connect the transmitter to the field strength measuring equipment. This line has an attenuation of 60 db at the fundamental fre-

quency of 32 mc; it will therefore have an attenuation of 137 db at the fifth harmonic at 160 mc. Thus, if the 60-db attenuation reduces the fundamental to 100,000 microvolts at the field strength measuring equipment and this equipment is capable of detecting a 0.3-microvolt signal at the fifth harmonic (160 mc), it will be possible to measure a 110-db difference. However, due to the 77-db correction necessary to take care of the difference in attenuation of the lossy line at the two frequencies, it is only possible to measure a 33-db difference. It is clear from this that if the fifth harmonic is only 35 db below the carrier, it will not be detected. Actually, for a satisfactory method of measurement, it must be possible to measure any spurious radiations that are not more than 100 db below the carrier level.

The limitation of the lossy-line method is shown graphically in Fig. 1A. This spectrum of transmitter radiation was measured by the method to be described, and all of those spurious radiations lying completely above the dashed line would not have been found had the lossy-line method been used.

Another problem inherent in all measurements of this type is accentuated in using lossy line. This is the problem of eliminating undesired coupling between the transmitter under test and the measuring apparatus. The voltage being measured between the inner and outer conductor of the lossy line is often small and unless adequate shielding is provided, the amount of signal obtained by undesired paths such as by direct radiation and by conduction along the outer conductor of the line may give readings that are in error by many decibels.

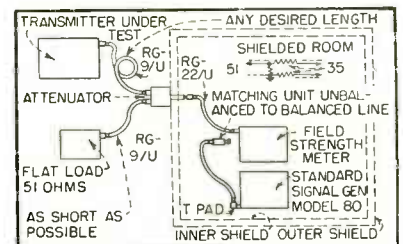

FIG. 4—Test setup for making measurements of spurious radiation



The method to be described substitutes for the lossy line an attenuator that has slightly less attenuation at the higher frequencies than at the fundamental. This attenuator is so constructed that it can be mounted in the wall of a double-shielded room. Figure 4 shows how the equipment is connected for making measurements.

### Improved Measurements

The transmitter under test is connected to the attenuator by means of a length of RG-9/U double-shielded coaxial cable and from there to a flat load or wattmeter that has a constant impedance over the range of frequencies in which measurements are being made. The attenuator construction illustrated in Fig. 5 shows that it will insert only a slight discontinuity into the line as a very short length of the center conductor is used inside the cavity of the attenuator. The secondary (coupling coil) couples to this length of the center conductor and thus a voltage is obtained proportional to the current flowing in the transmission line. The output of the attenuator is connected to the field-strength meter or receiver by a length of RG-22/U balanced, shielded transmission line.

After each measurement, the field-strength meter is calibrated by substituting the standard signal generator for the line coming from the attenuator. Since most generators now available have an unbalanced output, a matching unit is



Pipeline control and dispatching of mobile units is possible with two-way radio

used between the signal generator and field strength meter as illustrated.

### Attenuator Adjustment

Adjustment of the amount of attenuation provided by the attenuator

is made by moving the secondary coil relative to the short input loop. The plunger of the secondary coil assembly is marked to indicate positions of the coil for approximately 6-db steps. These various positions are calibrated against frequency by means of a standard signal generator. Calibration curves for the attenuator are shown in Fig. 6, giving the attenuation between the transmitter end of the RG-9/U and the field-strength meter.

Attenuation decreases with frequency, as would be expected from the nature of the device, making it possible to detect the higher harmonics more easily than the spurious radiations near the carrier frequency.

In addition to the attenuation position marks on the plunger of the secondary coil assembly, the plunger has a mark parallel to the axis so that the proper orientation between the coplanar primary and secondary coils can be retained. To improve the impedance match to the 95-ohm balanced output, an H-pad is inserted between the secondary coil and the plunger output.

Results using the method described above have been entirely satisfactory. With only reasonable care, it has been possible for different personnel to duplicate data within 2 or 3 db, on dates that are months apart and even for spurious radiations that are more than 100 db below the carrier.

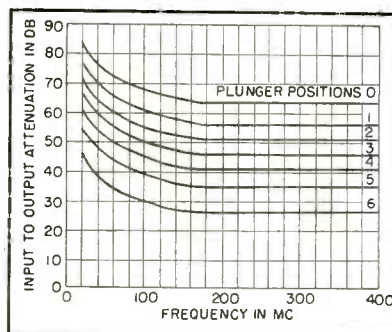

FIG. 6—Characteristics of attenuator shown in Fig. 5

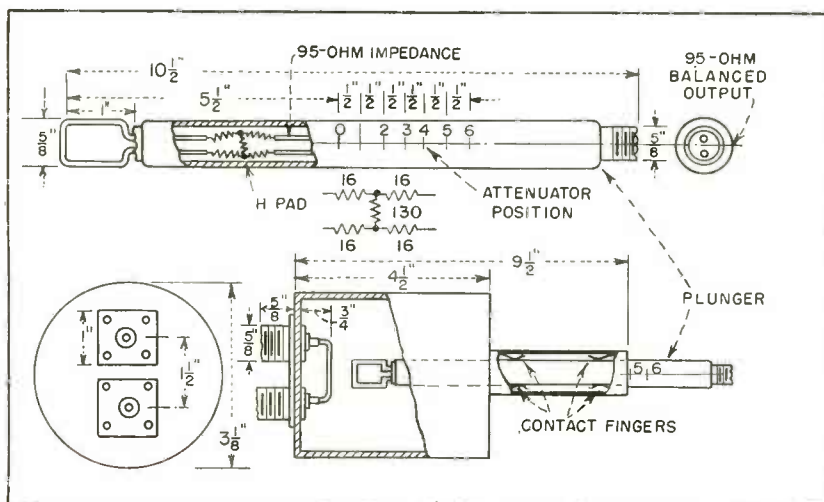

FIG. 5—Mutual-inductance attenuator with coplanar coils and 95-ohm output

# CITIZENS BAND Regulations

By **LEO M. CONNER**

W3GUP-W3XGW  
Brandywine, Maryland

**S**INCE the announcement on June 1, 1949 that the FCC would license stations for operation in the citizens band the commission's offices have been flooded with requests for more information. It is the purpose of this article to answer questions that are most often brought up.

It seems that many people long to own a radio station. They ask, "Will I be able to get a license even though I know nothing about radio?" The answer is, "Yes, if you are a citizen of the United States and 18 years of age or older."

The next question is usually, "How do I go about getting a license?" You write to the Federal Communications Commission, Washington 25, D.C., or to any of its Engineering Field Offices, and request a copy of Form 505. At the same time, send ten cents in coin (not stamps) to the Superintendent of Documents, U. S. Government Printing Office, Washington 25, D. C., and request a copy of the "Rules and Regulations Governing Citizens Radio Service."

Form 505 requires no special information so long as the equipment you are going to use has been type approved by the FCC. If the equipment has been approved then you need only fill in the information that is on the nameplate. This must include the type approval number.

Beware of transmitters offered as "suitable for use in the Citizens Band" that do not have type approval. One example of such a transmitter is the BC-645, available on the surplus market. This set is

not type approved and the FCC has not to date issued a license for its use in the citizens band.

One of the reasons the BC-645 gained early popularity was that the FCC did at one time license some of these sets as Class 2 experimental transmitters in order to get some activity started on the citizens band and obtain technical data before the band was officially opened to the general public. However, all Class 2 licenses for this type of service expired November 1, 1949 and none of them will be renewed.

The next inevitable question is, "Has type approval been issued for any set?" The answer is, "Yes". Type approval CR401 was issued to Citizens Radio Corporation of Cleveland, Ohio, for a camera-type portable set, and many pictures of this set appeared in trade journals. However, none were offered to the general public. Then, early in July, this firm sold their assets to Stewart-Warner Electric Corporation, Chicago, and this firm is making modifications and planning production. The FCC has already issued a new type approval, CR402, for a modified set. However, if the set is further changed or modified before it is released to the public an entirely new type approval will be needed.

### Transmitter Requirements

Delay in the sale of manufactured sets brings up a natural question, "Will the FCC license non-type-approved transmitting equipment?" Again the answer is, "Yes, provided it meets the standards set up for equipment in this band." To meet the standards you must file, with your application for license, information that proves that the equipment is capable of operating as set out in the regulations. If the station is to be operated at a fixed

location, then the frequency band 460 to 462 mc may be used by Class A stations. A Class A station may use up to 50 watts plate power input to the radio-frequency stage supplying power to the antenna and must be capable of maintaining a frequency tolerance of 0.02 percent. The communication bandwidth may not exceed 200 kc.

If the transmitter is to be operated in the frequency band 462 to 468 mc, the plate power input must be limited to 10 watts. This frequency band is also allocated for Class B stations which are authorized to use a plate power input to the radio-frequency stage supplying power to the antenna of 10 watts and are all adjusted to operate on the frequency of 465 mc. All operations (including frequency tolerance and communication band) must be confined to within plus or minus 0.4 percent of 465 mc.

For operation in the section 468 to 470 mc the transmitter may be designed for use at fixed locations or as a mobile unit using up to 50 watts power but must have the same frequency tolerance as for units operating in the 460 to 462 mc section of the band.

Since the FCC will not usually test composite units, information must be submitted to show that the transmitter meets the specifications. However, the Commission may require that the equipment or a prototype be made available for tests. Then users of such equipment must forward it to the Commission Laboratory, Laurel, Maryland, for tests. The transportation to and from the laboratory must be at no expense to the Government and all pertinent information must be sent with the equipment.

If you want to use composite equipment you must have a second-class radiotelephone or radiotelegraph license, or better, or have the



This interpretation of FCC rules answers such questions as: "Do I have to be a technician to get a license?" "What manufactured transmitters have been given type approval?"

"What must be done to obtain permission to operate homemade equipment?"

adjustments made by the holder of such license or under the supervision of such an operator who will be responsible for the proper functioning of the station. You must also have a commercial operator's license to service sets. An amateur license is no good for this.

### Operating Rules

The permissible communications for stations in the citizens band are set out in the regulations as follows:

"(a) Each station in the Citizens Radio Service is authorized to communicate with other stations in this service. Communications with stations licensed under other parts of the Commission's rules or with United States Government or foreign stations is prohibited." This means that, for example, an amateur owning both an amateur station and citizens band station can not use the citizens band station to work his own or another amateur station.

"(b) All communications in the Citizens Band shall be limited to the minimum practicable transmission time." You cannot give long-winded descriptions of the sights as you drive down the road.

"(c) Stations in this band may not be used for any purpose contrary to Federal, State or Local law; or to carry program material of any kind either directly or indirectly to the public through public address systems or by any other means." In other words, you cannot use your citizens radio service equipment to relay race results for rebroadcast over a p-a system outside the track, you cannot charge Mrs. Jones for relaying a message to her husband, and you cannot have little Mary sing for the neighbors.

"(d) A Citizens Radio Station used for radio control of devices or

objects shall not be used where its operation involves continuous radiation of energy by the station for operational control of such apparatus." This means that if a tone-modulated signal is used to provide separate control functions for model planes, boats or other similar devices, the carrier cannot be left running. It must be started and stopped with the tone.

"(e) A Citizens Radio Station used for the purpose of communication by radio telephone shall not emit a carrier wave unless modulated for the purpose of communication, and when using telegraphy, radiation of energy shall not occur except when telegraphic signals are being transmitted, excepting for brief tests or when adjustments are being made on the transmitter." In other words, you cannot leave the carrier on while you talk on the telephone or to let the neighbors hear the brawl you are staging.

An unusual method will be used to identify stations of the citizens radio class. The registered serial number appearing on each citizens radio station license will be the call signal assigned to the station. A station must transmit its call signal at the beginning and at the end of each communication as well as once each ten minutes during communications of more than ten minutes duration. Stations being used solely for the control of devices or objects are not required to identify transmissions.

When Mr. Conner's article was received the editors of ELECTRONICS relayed it posthaste to the Commission for comment.

Back it came with just a few additions and changes, which have been included here

The frequencies used in this service are available on a shared basis only, which means that in areas where a number of sets are operating there may be some heavy interference. The users of the service are expected to cooperate in obtaining the most effective use of the frequencies. The transmitters must be under control of the licensee at all times. This does not mean that the wife, husband or children of a licensee cannot operate the equipment when the licensee is not physically present. In the case of other members of the family or employees of the licensee operating the equipment it must be under the control of the licensee.

### Intended Uses

From the foregoing it will be seen that the Citizens Radio Service is designed as a private short-distance radio communication, radio signaling and radio control service with minimum licensing requirements. It definitely is not a band for experimenters and the circuits may not be changed from the circuit originally licensed without permission of the FCC. However, the FCC does not care what you do to the receiver so you can experiment all you want in that direction. No information on the receiver is required in filing for license.

At first glance the requirements look rather stiff but the transmitter described in ELECTRONICS for November, 1947, is a good starting point if you want an f-m transmitter. Another idea is to use a-m, starting with a crystal oscillator and multiplying to 460-470 using tubes of the 6J6 type as push-pull triplers or push-push doublers. Amateurs using similar equipment and high-gain arrays have worked distances in excess of 200 miles using 420 mc. Activity on the citizens band may show similar results.



External view of optar guidance device for the blind

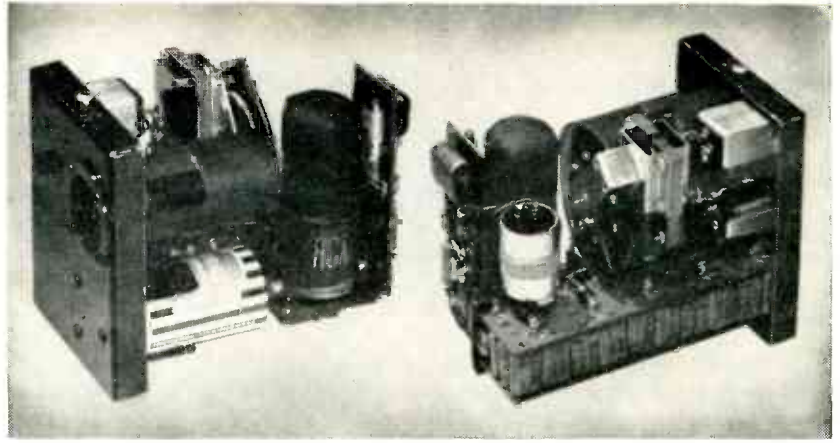

Two internal views of the guidance equipment. Size is indicated by the flashlight cell view at left. Stack of voltage-multiplier elements appears at bottom right

# OPTAR—A New System of —Optical Ranging—

Photoelectric exploration of images formed by lens reveals location of objects over short ranges. Applications include a wide range of optical controls, including automatic camera focusing, infrared "radar", and devices to guide the blind

**A**N ingenious combination of optical and electronic principles was described recently before the New York section of the IRE by H. E. Kallmann. The system, known as optar ("optical automatic ranging"), makes use of a lens, a light-chopper, and a high-sensitivity phototube to explore space for illuminated objects, such as radar explores space for reflecting objects. Unlike radar, however, the optar principle is suited for exploration over short ranges, from a few inches to a few hundred feet, depending on the focal length of the lens.

The applications include optical controls, such as an automatic focussing attachment for movie and television cameras, short-range radar detection using infrared radiation, and guidance for the blind. The latter use was the first to be developed in detail by Dr. Kallmann, who demonstrated a portable ranging device which locates the posi-

tion of illuminated objects and translated their positions into audible signals

## The Optar Principle

The basic principle of the optar system is shown in Fig. 1, which illustrates the conventional action of a lens. The objects in front of the lens,  $h_1, h_2$  occupy positions at distances  $a_1, a_2$  from the center of the lens system. Corresponding to the objects are images  $i_1, i_2$ , at image distances  $b_1, b_2$ . So long as the objects are located further from the lens than the focal length  $f$ , a separate real image is formed for each object  $h$ . It is possible, therefore, by exploring the space on the image side of the lens, to locate the image and to translate the image distances into the corresponding object distances.

The translation process is illustrated in Fig. 2, in which the image distance is shown for corresponding object distances, each expressed

as a multiple of the focal length. This figure reveals that the separation of the images decreases roughly in proportion to the square of the object distances. It follows that ranging by this system is most accurate at short distances, i.e., within 200 times the focal length of the lens. At greater object distances the images fall so close together (near the focus of the lens) that it is difficult to separate them.

The essential problems are: (1) to determine the position of a single image, and (2) to explore the image space systematically for all the images it contains. These problems are solved by an ingenious light-chopping technique. The process consists of moving a series of parallel opaque bars (like the teeth of a comb) across the image space of a wide aperture lens. In consequence of the motion, the light passing through the teeth is modulated at a frequency equal to the number of bars per second



## Power consumption: 90 milliwatts

In the extraordinary blind-guidance device developed by Dr. Kallmann as his first application of the optar principle, the following items are included: A wide-aperture lens, a light chopper driven by a 1350-rpm motor, a 931-A photomultiplier tube operating at 1,000 volts. The only power source is a single standard flashlight cell operating at 60 ma, good for 100 hours continuous use!

passing a given point in the image. If the plane of the comb and the image plane coincide, the modulation percentage is a maximum. However, as the planes of the image and comb move apart, the percentage modulation decreases rapidly and falls substantially to zero when the two planes are separated by a small fraction of the focal length. A phototube views the light passing through the teeth, and the a-c component of the phototube current is an indication of the presence or absence of an image.

To explore the image space systematically, the comb may be moved through the space repeatedly in planes successively further removed from the focus of the lens. The phototube current then indicates, by the magnitude of its a-c component, each position at which the comb coincides with an image, and all the images are thus successively indicated. By noting the position of the comb when an a-c component appears and reaches a maximum, reference to a chart like Fig. 2 (or a similar calibrating device) indicates the corresponding object distance. The arrangement of the system is shown in Fig. 3. The curve at the bottom illustrates the manner in which the magnitude of the a-c component varies as the plane of the comb is displaced from the image plane.

Thus far we have considered a sharply defined image of an object occupying a small part of the field of view. When an extended object is viewed, the optar device operates on the differences in the brightness of various parts of the object. No modulation whatever occurs when an area of uniform brightness occupies the whole field of view, except the random noise component of the steady photoelectric current.

The more details are present in the image analyzed by the chopper, the more likely will be the modulation components, caused by each, to cancel each other. For random distribution of object details, the extent of the mutual cancellation must be studied by statistics, complete cancellation being the most probable result. But the fact that the probability curve has a definite width, indicates that incomplete cancellation also has a definite probability. At present, optar devices utilize only the incompletely cancelled modulation signals, which are necessarily of small amplitude.

Since the modulation signals are weak, it is necessary to maximize the signal-to-noise ratio, and this brings up the question of how large a portion of the total field of view should be intercepted by the phototube. Analysis shows that the

signal-to-noise ratio of the device is independent of the interception area. This follows from the fact that both the signal and noise component increase as the square root of the number of small dark and bright areas comprising the image.

## Differential System For High Precision

The precision with which the optar system can measure distance depends on the shape of the curve shown at the bottom of Fig. 3. For precise range measurements a differential form of the system, shown in Fig. 4, may be used. In this case, two combs are used. These occupy parallel planes and are separated a small distance along the optic axis. When centered, one comb passes slightly behind the image, and the other thereafter passes an equal distance in front of the image. The two successive a-c components are effectively subtracted, by rectification and passage through a d-c meter whose polarity is reversed as the back and front combs interchange positions. Thus two curves, like that in Fig. 3, are subtracted and a differential curve, identical in principle to that of the discriminator detector, results.

When the two combs are positioned an equal distance in front of and behind the image, the net re-

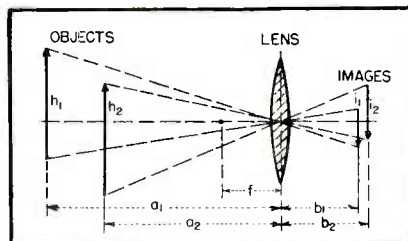

FIG. 1—The optar system measures the distance to an object by locating its image

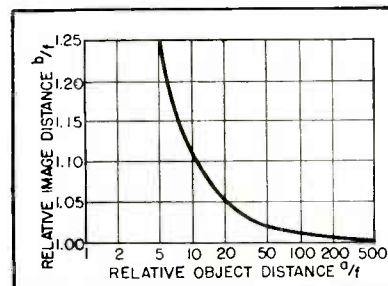

FIG. 2—Relation between object distance and image distance, expressed in terms of the focal length

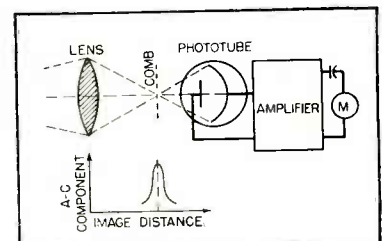

FIG. 3—Fundamental optar system. The curve shows variation in a-c component as comb is displaced

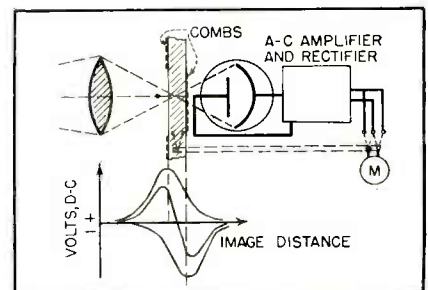

FIG. 4—Differential arrangement for high precision. Subtraction of components permits null measurement

sponse of the d-c meter is zero. Thus, the broad maximum measurement is replaced by a null measurement, and correspondingly high precision can be obtained. The disadvantage of the differential scheme is that the range of image position over which the device can operate is limited to the straight slope in the middle of the discriminator curve.

The differential system can be used for precise optical control, as in automatic focusing of cameras, by the circuit shown in Fig. 5. Here two disks, carrying the comb segments, are rotated by a motor through the image space. The resulting a-c components are separated into two paths, by a gating signal synchronized with the motor. The two separated a-c components, corresponding with the respective comb segments, are rectified and applied to opposed field coils of a servo motor. The motor then rotates whenever the pair of comb segments is not centered about the image plane, and the rotation may

be used to control the position of the lens until the centered condition is regained. Thereafter, the motor moves to follow any change in the position of the object. This is precisely the action required for automatic focusing of motion picture or tv cameras.

The device may also be used to control machine tools in terms of the changing position of an illuminated surface or index mark.

### Optar For Guidance of the Blind

The first device built by Dr. Kallmann on the optar principle is the guidance device illustrated in the accompanying photographs. In order to operate the device as one would use a flashlight, it must be small, both in size and in power consumption. Economy in power consumption is a prime requisite for such a guidance device. Dr. Kallmann has succeeded in reducing the power supply to a single flashlight cell, operating at a current drain of 60 ma, or a total

power output of 90 milliwatts. The fact that a photomultiplier, motor and audio stage can be operated from this minute energy source is one of the noteworthy achievements of the design. Simplified mechanical and circuit schematic diagrams are shown in Fig. 6. Included in the device are the lens, a push-button which opens the lens aperture and operates the power switch simultaneously, and a motor driving a disk on the periphery of which is carried a film printed with comb segments as shown in Fig. 7. The film is fitted to the disk in spiral fashion, so that, during each revolution of the disk, the plane of the comb travels once throughout the image space of the lens.

The light passing through the comb is collected by a 931-A multiplier phototube. The ten stages are operated at 80-120 volts per stage. With increasing illumination, the current drain on the power supply causes all voltages to drop. This reduces the amplification so the output increases approximately as the logarithm of the ambient illumination. It follows that the amplitude of the modulation at the output is a measure only of image detail, but independent of ambient illumination. Therefore, no gain control is needed. The background noise, decreasing with the square root of ambient illumination, determines the minimum light requirement. The present model will operate with less than one footcandle of ambient illumination,

Any tone heard in the headphone indicates the presence of an illuminated object possessing some degree of optical contrast. The spacing of the opaque bars on the film is decreased in 8 steps, as shown in Fig. 7, and the frequency of the modulation increases correspondingly. As a result, the pitch of the tone heard indicates the range of the object, in 8 zones covering a total distance range of 1.5 to 20 feet. The shape of the curve in Fig. 2 causes the depth of each zone to become smaller, the closer the zone is to the lens. Thus, the sightless person is given more precise range on nearby objects, as required for his convenience and protection. The construction of the device is shown in the photographs. The current

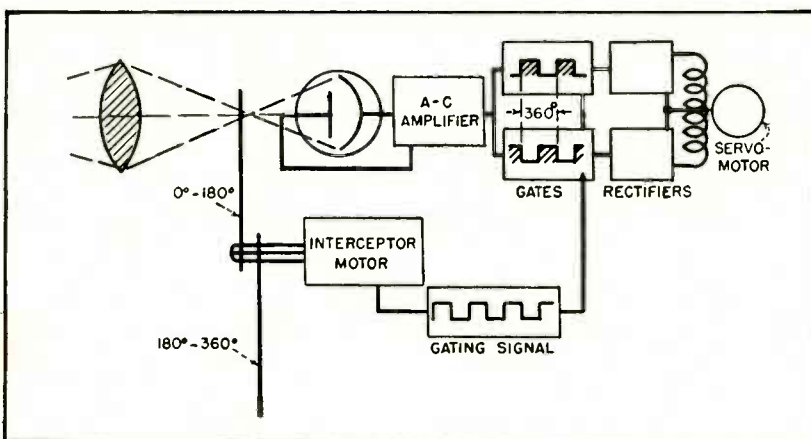

FIG. 5—Practical setup of differential ranging device, arranged to control motor and suitable for automatic camera focusing

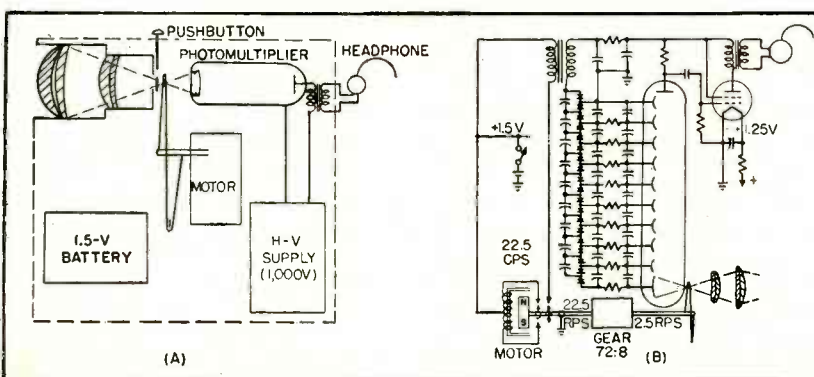

FIG. 6—(A) Mechanical arrangement of blind-guidance device. (B) Simplified schematic. This circuit operates with 90 milliwatts of primary power



model weighs two pounds and measures 3 by 4 by 5 inches. Dr. Kallmann states that a model weighing only three-quarters of a pound measuring about 1½ by 2 by 4 inches can be built.

The motor is a split-field commutator type, having a two-pole armature of alnico. It operates at 22.5 revolutions per second at 1.5 volts, 15 ma, and has very good speed regulation, as is required to provide constancy of pitch in the audible signals. Carried on the shaft of the motor is an interrupter which operates at 22.5 cps. This applies a pulsating current to a miniature power transformer which develops about 100 volts a-c across its secondary. The high-voltage power is developed by a ten-stage voltage multiplier, consisting of a stack of miniature selenium rectifiers and appropriate capacitors and resistors, as shown in Fig. 6. The first stage of this multiplier also feeds into the audio output stage, the filament of which is connected to the flashlight cell. An a-c power output of about 0.2 milliwatt is fed to the headphone. The rotating drum carrying the comb segments is driven by the motor through a 72 to 8 gear reduction, so the drum speed is 2.5 revolutions per second. The comb segments are laid out (Fig. 7) in eight 45-degree sectors. The frequency of the a-c component (the rate of passage of the bars) varies from 600 to 2,000 cps. The comb is so arranged that the highest pitch is produced in the nearest zone.

The person using the guidance device quickly learns to associate a given series of tones with a corresponding arrangement of objects in front of him. Since the device scans only in depth, it is desirable to move the instrument slowly from left to right, to distinguish the lateral edges of the objects detected.

The choice of the number of zones, the frequencies of each, and the rate at which the tone sequence repeats itself, have been chosen as compromises between precision of ranging on the one hand and flexibility of use on the other.

Figure 8 illustrates an optar device which explores the image space in the manner just described and is

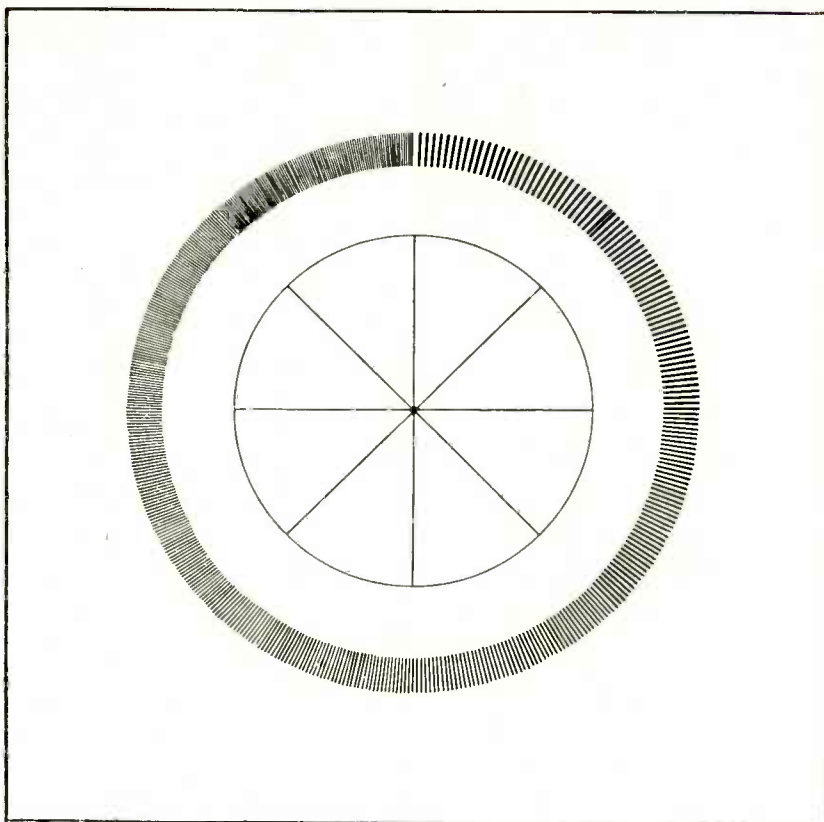

FIG. 7—Arrangement of comb teeth, as seen end-on along axis of drive motor. The eight zones produce tones varying from 600 to 2,000 cps

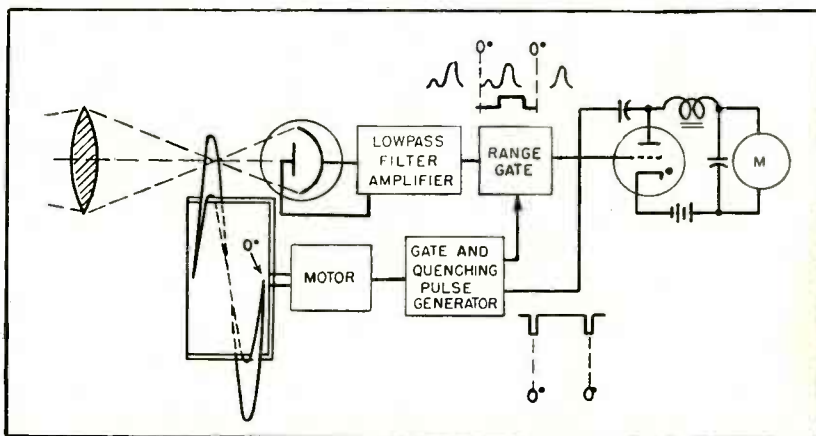

FIG. 8—Ranging device for indicating presence of objects at a pre-set range, selected by shifting the range gate

intended to provide an indication of distance together with power for actuating a control. In this case the comb segments are equally spaced, and a fixed "carrier" frequency is produced as each image is passed through. A low-pass filter passes the envelope of the carrier frequency only. Synchronized with the motor drive is a "range gate" generator which allows the envelope to pass only if it occurs within a given time (caused by an object at a given distance). Thus,

unwanted signals, such as arise from a face in the foreground, may be excluded. The envelope passed triggers a thyatron which actuates a control and an indicator calibrated in distance. A quenching pulse causes the thyatron to cease conduction and it remains inactive until the next signal envelope passes the gate circuit. Since, in this case, the ear is not the frequency limiting factor, complete ranging may be repeated as often as a thousand times per second.—D.G.F.

# Simplified Intercarrier

Reduction in number of tubes and tuned circuits is provided by application of the gated beam 6BN6 to the intercarrier sound system of a receiver. Suppression of a-m compares favorably with other f-m detectors as does suppression of ignition interference

**I**NTERCARRIER SOUND claims a few advantages over the conventional system in the overall operation of the receiver as well as in the initial design.

The most important benefit of the system is the oscillator stability requirement. The sound subcarrier is dependent only upon the beat between the sound and picture carriers and not the local oscillator frequency, excessive drift of which cannot be tolerated in the conventional system. The trend toward the use of 40-mc i-f makes intercarrier sound extremely attractive since 4.5-mc is far easier to handle than 40-mc, especially in the design of the discriminator or ratio detector transformers.

Keen competition in the manufacture of television receivers demands the utmost in economy and simplicity. With the development of the 6BN6 gated beam tube by Robert Adler<sup>1</sup> of Zenith and its subsequent mass production by the General Electric Company, an intercarrier sound system embodying increased simplicity and economy can be realized.

In the typical intercarrier receiver, the sound and picture carriers are amplified in a common i-f amplifier. The 4.5-mc beatnote between sound and picture carriers is detected at the second detector and usually amplified, either in the video stages or separately, before it is separated and fed into an f-m detector. Since the frequency of the beatnote varies directly as the sound carrier, the output of the f-m detector contains the audio modulation of the sound carrier. The audio signal is then fed to a conventional audio amplifier system.

The biggest design problem is to minimize the incidental amplitude

modulation of the 4.5-mc beatnote. This problem arises because even the best f-m detector circuits do not suppress a-m entirely. The most important step in this direction was taught by L. W. Parker<sup>2</sup> and R. B. Dome<sup>3</sup>. Through the video i-f channel the bandpass must be shaped so that the level of the sound carrier is approximately 20 db below the peak picture carrier level at the second detector.

A video i-f bandpass characteristic to accomplish this desired sound-to-picture ratio is shown in Fig. 1. The 6-db bandwidth is about 3 mc. It would be desirable to have a narrow shelf in the i-f bandpass at the sound carrier so that no slope

detection of the sound carrier would occur. This is indicated by the dashed-line curve. The shelf costs an extra tuned circuit, however, and it has been found unnecessary if the slope of the i-f curve is not too steep.

If the sound carrier level is 6 db below the minimum picture carrier level, the amplitude of the beatnote in a linear detector is substantially unaffected by picture carrier amplitude. However, at low levels where the detector is operating according to a square law, the beatnote amplitude varies greatly with sync and video modulation. Therefore, it is desirable to operate the detector at a high enough level so that detection is substantially linear. The detector output level varies from approximately 1.5 to 5 volts between various makes of receivers, assuming a signal strong enough to produce a picture of reasonable entertainment value. For marginal and submarginal reception, the detector level is frequently only a fraction of one volt.

Obtaining the proper sound-to-picture carrier ratio at the second detector is just the starting point in reducing the amplitude modula-

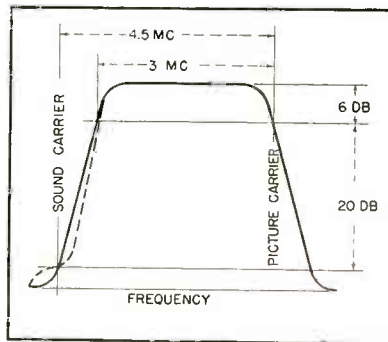

FIG. 1—Required overall response of video i-f stages

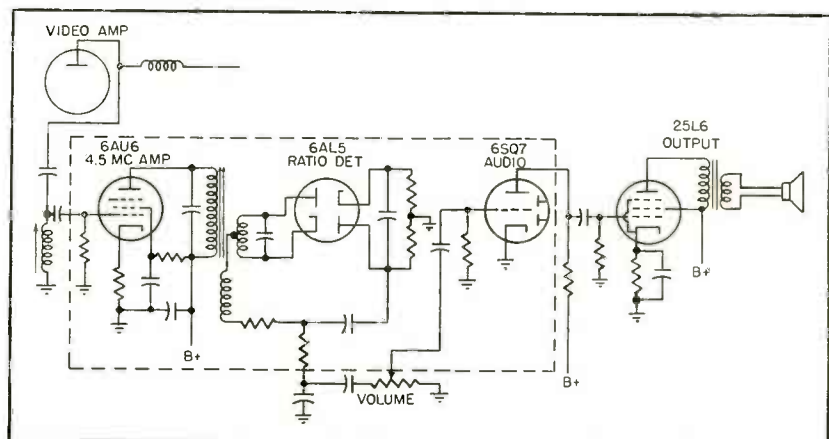

FIG. 2—Circuit most often used for intercarrier sound takes 4.5-mc beat at plate of video amplifier



# Sound

By **WALTER J. STROH**

Zenith Radio Corporation  
Chicago, Illinois



Subassembly chassis of the sound channel having the simplified circuit arrangement

tion. Any nonlinear amplification or overload in the i-f stages or in the video stage will introduce an a-m component on the 4.5-mc beatnote. In the video i-f chain, the last stage is most likely to overload. When overload occurs, the gain of the sound carrier varies with video modulation. To reduce overload possibilities, the last transformer in a stagger-tuned i-f system should be tuned to the picture carrier side, and all the damping of the stage should be produced by the diode. In so doing, the grid swing required of the last i-f is minimized.

Another place for incidental amplitude modulation to occur is in the video amplifier stage. The video amplifier is a high-level amplifier and must operate with a large grid swing. The transconductance of the stage as a 4.5-mc amplifier will vary with video and sync modulation, especially when the grid is driven hard. This variation causes amplitude modulation of the 4.5-mc beatnote.

If the envelope of the 4.5-mc signal is observed, one would notice that indentations in the 4.5-mc envelope occur during the vertical sync pulse periods. The shape of

the indentation would look exactly like the vertical blank and sync pulse.

The depth of the indentation or the percentage of downward modulation is determined by the degree of transconductance change of the video amplifier as the sync pulse drives the grid toward cutoff. For example, in some intercarrier receivers a raspy buzz is produced in the sound when the contrast control is advanced. In these receivers the contrast control is located ahead of the grid of the video amplifier and overload of the amplifier has occurred as a result of being overdriven.

## Intercarrier Buzz

Even though all the proper precautions to minimize amplitude modulation of the 4.5-mc beatnote have been taken in the design of the intercarrier receiver, it is subject to buzzy sound due to transmitter operation. If a transmitter is 100-percent modulated during the white portions of the picture, there will be frequent intervals in which the

picture carrier level at the second detector will be zero; and, hence, the 4.5-mc beatnote amplitude drops to zero. The result, of course, is 100-percent amplitude modulation of the 4.5-mc signal, causing what is termed intercarrier buzz.

With a conventional sound system, 100-percent modulation of the picture transmitter does not affect the sound. It is hoped that the broadcasters will soon realize that intercarrier type receivers are becoming a substantial portion of the total number of sets in use, and that they will govern their operation accordingly by limiting the modulation percentage of the picture carrier to 85 or 90 percent.

Figure 2 shows the schematic diagram of an intercarrier sound system of a typical receiver.

The 4.5-mc beatnote is selected from the plate of the video stage by a resonant circuit and is fed to a ratio detector driver tube. The amplified signal is fed into a conventional ratio detector circuit using a 6AL5. The audio output is fed to an amplifier stage and then to a power output stage driving the loudspeaker. The portion of the circuit enclosed by the dotted line can be replaced by one tube, the 6BN6, and two single-tuned circuits.

The circuit of Fig. 3 is used in a few commercial receivers. Here the beatnote is taken off at the second detector. The 4.5-mc signal is amplified in two driver stages to make up for the gain lost by not utilizing the video amplifier.

The signal is demodulated in the conventional ratio detector and the audio output amplified in the conventional manner. Again the portion of the circuit enclosed by

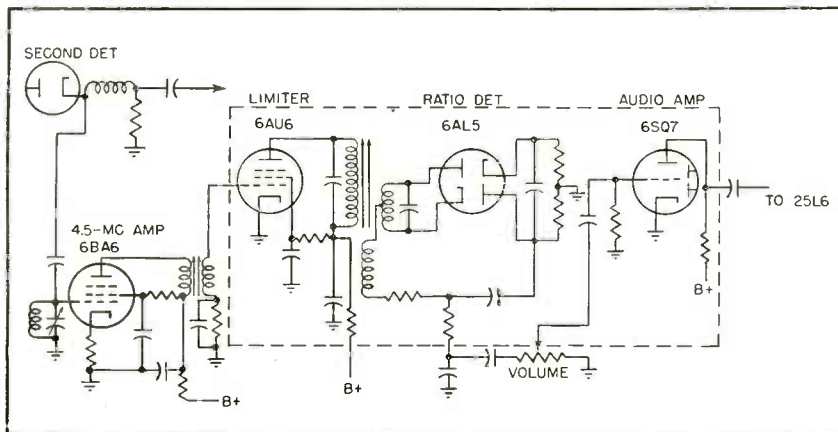

FIG. 3—Alternative circuit takes beat at video detector, requires additional amplifier

dotted lines can be replaced by a single 6BN6 tube.

Figure 4 is a block diagram of an intercarrier sound system utilizing a 6BN6 tube. For a tube to perform in this circuit arrangement, it must be a good limiter with a high limiting sensitivity, and it must be an f-m detector with sufficiently high audio output to drive a power stage directly. The 6BN6 gated beam tube fulfills the above requirements.

The schematic of Fig. 5 shows the 6BN6 in an intercarrier receiver performing the functions of a limiter and a discriminator.

The 4.5-mc beatnote from the plate of the first video stage is selected by a transformer whose primary is tuned to resonance at 4.5 mc and whose secondary is untuned and closely coupled to the primary. The first video stage is safe to utilize as an extra gain stage in this circuit because it is operating as a linear amplifier. Also the maximum output of the second detector is limited by agc circuits and the contrast control is located in the second video stage. Therefore the possibility of the first video being driven into an overload condition is eliminated.

The 4.5-mc signal is coupled to the grid of the triode amplifier stage through a small capacitor. This triode amplifier is not neutralized and is highly degenerative by virtue of the voltage feedback ratio determined by the grid-plate capacitance and the 10- $\mu$ f coupling capacitor. Its gain is approximately six. In the plate circuit of the triode is a single-tuned step-up transformer tuned to 4.5 mc. The step-up transformer is placed in the grid circuit so that the grid has a low d-c resistance to ground as

required by the 6BN6. The B+ choke has a high impedance at 4.5 mc.

The amplified 4.5-mc signal is fed to the limiter grid of the 6BN6 at a level of approximately 5 volts rms. The exact level depends upon the output from the detector, the sound-to-picture amplitude ratio of the transmitted signals, the attenuation of the sound carrier in the i-f amplifier and upon the gain factor of the amplifier stages.

The gain required in the amplifier stage or stages between the detector and the limiter grid of the 6BN6 depends not only upon these factors but also upon the weakest signal or minimum detector output for which satisfactory sound is expected. For instance, assume 0.5 volt for this minimum level. With the sound carrier 20 db farther down, it has an amplitude of about 18 millivolts rms; to bring this up to the limiting level of 1 volt rms requires a gain of 55 times or 35 db.

The circuit shown in Fig. 5 provides a gain of 43 to 46 db. A number of circuit arrangements is possible. Utilizing the video stage should be done with caution, guarding against possible downward modulation. A single pentode amplifier stage between the second detector and the limiter grid might be preferred and would provide sufficient gain.

### A-M Suppression

One of the most important characteristics of an f-m detector is its ability to suppress amplitude modulation. In this limiter-discriminator circuit using the 6BN6 the audio output is taken directly from the anode so that amplitude modulation may slip through as a result

of spurious plate-bend detection. This tendency is minimized by careful adjustment of the limiter grid bias.

The plate current-grid voltage curve of the 6BN6 resembles a step-function characteristic having an upper and lower knee. If the grid is biased too highly negative, plate-bend detection occurs at the lower knee and the average plate current tends to rise with increased signal. If the grid bias is not negative enough, plate-bend detection of the reverse kind occurs at the upper knee and the average plate current drops with increased signal.

There is an optimum grid bias at which the plate current will stay constant with increased signal. This grid bias point coincides with best a-m rejection. An adjustable control rather than a fixed resistor is placed in the cathode of the 6BN6 to obtain optimum bias because of tube tolerance variations. When the circuit is properly adjusted, the a-m suppression compares favorably with other f-m detectors in commercial use, and the gated beam detector appears to have the edge in suppression of ignition interference where other circuits are burdened by time constants.

The circuit does not contain a balanced transformer that requires critical adjustment. If the signal impressed upon the limiter grid were 30 percent a-m and 30 percent f-m, modulated simultaneously, the a-m audio component appearing in the audio circuit would be at least 20 db below the f-m component. This holds true for levels of input signal above approximately 1 volt, well below normal.

As a result of the quadrature voltage developed across the tuned circuit in the second grid, f-m detection takes place and the audio information is developed across the 220,000-ohm load resistor.

### Discriminator Bandwidth

Figure 6 shows typical discriminator response produced by the 6BN6 with a 4.5-mc center frequency. The most conspicuous difference between this curve and the one for a conventional discriminator is the absence of any sharp curvature beyond the range of

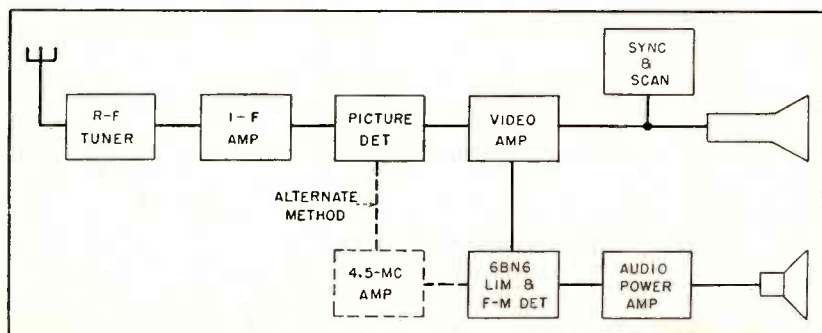

FIG. 4—Block diagram of intercarrier sound system using the 6BN6 gated beam tube



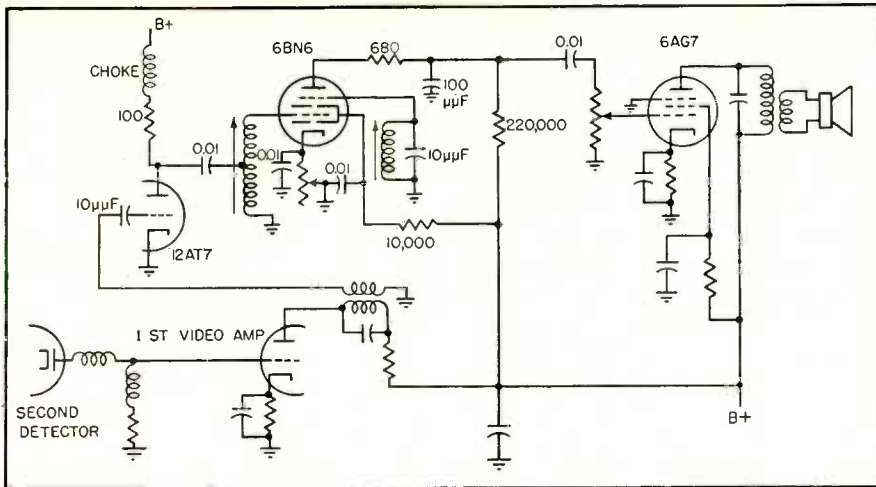

FIG. 5—Schematic of intercarrier sound system with 6BN6 functioning as limiter and f-m detector

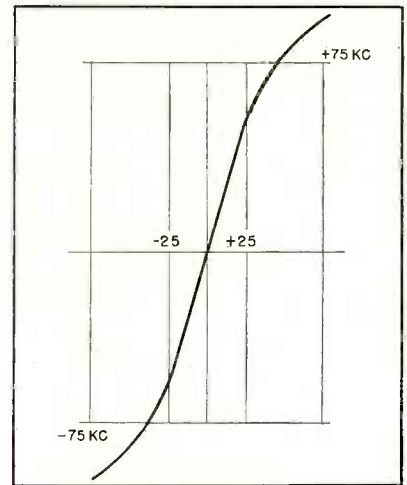

FIG. 6—Typical discriminator response for the gated beam tube

normal signal deviations. The harmonic distortion for 25-kc deviation is approximately 2.5 percent.

The bandwidth of the usable portion of the discriminator curve is proportional to the bandwidth of the quadrature circuit. Higher L-C ratio in this circuit results in a broader curve. Further broadening can be obtained by damping the quadrature circuit with a resistor but this results in impaired audio output and poorer a-m suppression.

The bandwidth can be increased by a better method used in this circuit. A small resistor (680 ohms) is inserted between the anode and the bypass capacitor. The insertion of this resistor has two effects: it damps the quadrature circuit but also supplies more energy to it. As a result, the voltage across the quadrature circuit will stay constant or even rise while the bandwidth is increased. Good audio output and improved a-m suppression result.

The plate bypass capacitor provides the correct amount of de-emphasis.

The stability of the quadrature circuit is important. It should not have excessive frequency drift with temperature and humidity changes. The fixed tuning capacitor across the quadrature circuit, therefore, has a specified temperature coefficient.

### Output

The audio output which can be obtained with low distortion is largely a function of the plate sup-

ply voltage. In this circuit there is 160 to 170 volts available, and with full 25-kc deviation 15 volts rms audio output is normal with approximately 2-percent distortion. With higher plate voltage and a smaller damping resistor, it is possible to obtain 20 to 25 volts rms audio output with a harmonic distortion of 3 to 5 percent for 25-kc deviation.

With this level of audio output, the usual audio amplifier stage can be omitted and the detector output fed directly into the power tube.

If the transmitting stations could be counted upon to maintain their audio modulation percentage above 30 percent of 25 kc, a 6K6 power tube could be driven to practically full output. But to take care of those times when the percentage modulation of the sound carrier is extremely low, we have chosen to use a 6AG7 power output tube because of its high power sensitivity. A 6V6 or a 25L6 would be sufficient in most cases.

Only three adjustments are necessary. The step-up transformer is tuned for maximum 4.5-mc signal at the limiter grid. The quadrature circuit is tuned for maximum undistorted audio output, and the bias control in the cathode of the 6BN6 is adjusted for maximum a-m rejection.

The intercarrier sound system described has been designed for use in a receiver of highest quality with performance comparable to conventional sound type sets. For receivers where cost is a major con-

sideration, the triode 4.5-mc amplifier may be eliminated by extracting the beatnote from the video amplifier and applying the signal directly to the limiter grid of the 6BN6 through a suitable coupling transformer.

The exact amount of intercarrier gain required between the video detector and the limiter grid of the 6BN6 depends, as has been pointed out, on the sound-to-picture carrier ratio produced in the i-f channel, and on the lowest video signal level at which satisfactory sound is expected. We have found that it is not at all hard to obtain gains of 35 db at 4.5-mc in a pentode video stage by using good circuitry to separate the intercarrier signal from the video frequency band. The main problem remaining in such a circuit is the necessity of avoiding a-m modulation of the 4.5-mc beatnote by the video signals due to overload in the video stage. This is most easily taken care of if the maximum video level is limited by automatic gain control circuits.

The author is indebted to Robert Adler for his valuable assistance and direction in adapting the 6BN6 as the limiter-detector of an intercarrier sound system. He is also indebted to Nathan Aram for his help in the preparation of this paper.

### REFERENCES

- (1) Robert Adler, The 6BN6 Gated Beam Tube, *ELECTRONICS*, p 82, Feb. 1950.
- (2) L. W. Parker, TV Intercarrier Sound System, *Tele-Tech*, p 26, Oct. 1947.
- (3) R. B. Dome, Carrier Difference Reception of Television Sound, *ELECTRONICS*, p 102, Jan., 1947.

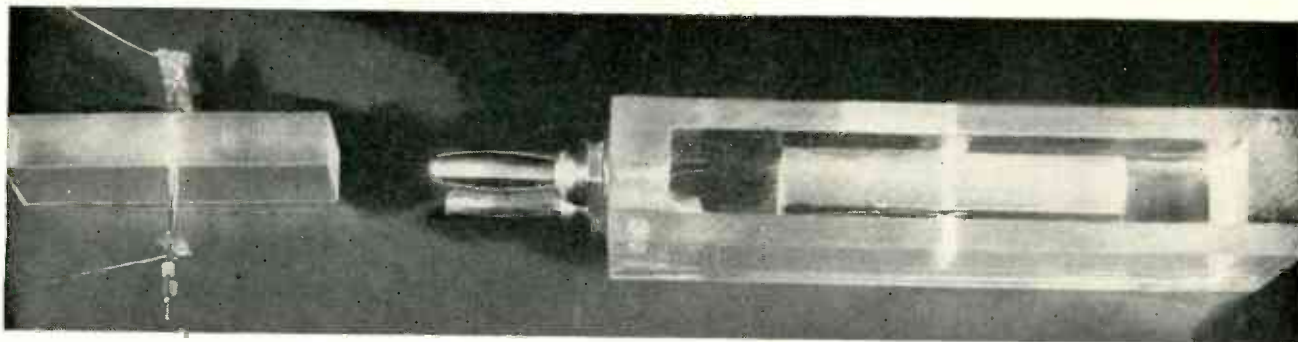

ADP and RS crystal mountings of this type provide highest Q (up to 30,000) and greatest mechanical stability. Holes can be drilled in crystals with ordinary twist drill

# Synthetic Crystals at Ultrasonic Frequencies

By **CHARLES E. GREEN**  
U. S. Navy Electronics Laboratory  
San Diego, California

**S**YNTHETIC CRYSTALS possess characteristics that compare favorably with quartz, particularly in the frequency range of 10 to 150 kc. Their greatest limitation, dependence of operating frequency on temperature, is often counter-balanced by their softness and ease of handling. Relatively few experimental applications require stability greater than that offered by either the ammonium dihydrogen phosphate or Rochelle salt synthetic types.

Little has been published on the handling and in-use characteristics of these valuable circuit elements. This paper is intended to present a picture of recent developments and techniques, and to acquaint the reader with the inherent limitations and advantages of synthetic crystals.

Many of the problems encountered in quartz crystal work are

paralleled in dealing with synthetic crystals. In both cases, the ratio of physical length to width must be considered. To reduce the effects of width resonance and side loading, the thickness should be  $\frac{1}{2}$  to  $\frac{1}{4}$  the width, the larger ratio being used for the higher frequencies.

### Physical Dimensions

Figure 1 is a graph for computing the physical dimensions of ADP and RS crystals for specified frequencies. The width-to-length ratios are plotted against an arbitrary  $X$  that can be used in the formula  $L = X/f_r$ , where  $L$  is the length of the crystal in inches,  $X$  is determined from Fig. 1, and  $f_r$  is the resonant frequency of the crystal in kc.

A synthetic crystal bar larger than that required can be reduced to the desired dimensions by sanding the ends and sides with ordinary fine sandpaper. It is advisable to polish the sanded edges with clean cloth moistened with some solvent such as benzene to insure the removal of oil, moisture and crystal dust. Water should not be used, since synthetic crystals are

water soluble. A satisfactorily cleaned crystal will measure better than  $10^6$  ohms d-c resistance.

The contacts consist of a 0.0005-in. silver foil bonded with a 0.0005-in. thick joint of Bakelite cement. Electrical contact is most satisfactorily made by pressing a foil tab against the crystal foil at the node.

The attachment of the crystal to the mount is critical in determining whether the crystal will oscillate or not. It is the mounting technique that enables the high Q of the crystal to be realized.

Several types of suspension have been tried. Comparative results indicate that the type shown in the accompanying photographs not only permits the highest Q, but also affords the greatest mechanical strength. Holes are drilled through the crystal along the nodal line, which runs across the center of the crystal bar at the point of minimum mechanical motion.

If the crystal is less than  $\frac{3}{8}$  inch in width, only one hole in the geometric center of the foil is required. When the width is from  $\frac{3}{8}$  to  $\frac{1}{2}$  inch, two holes should be spaced from  $\frac{1}{8}$



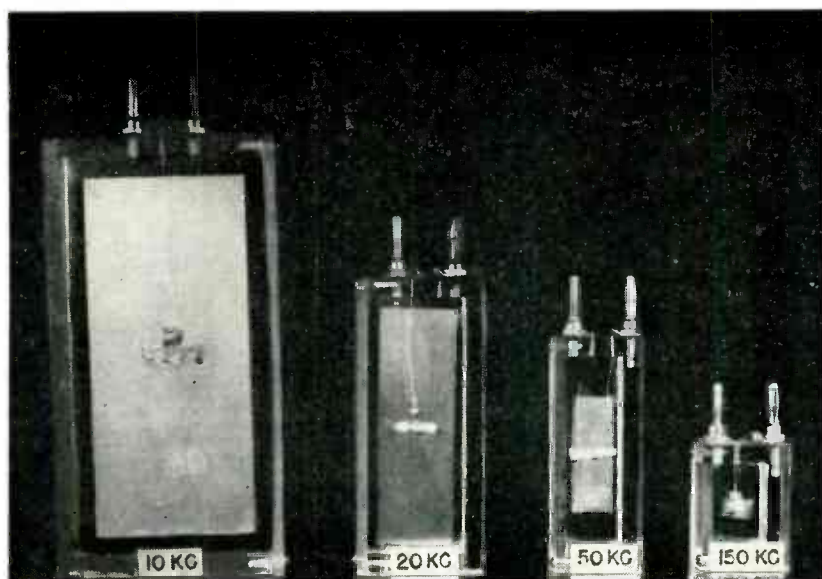

Several synthetic crystals are shown here approximately half their actual size

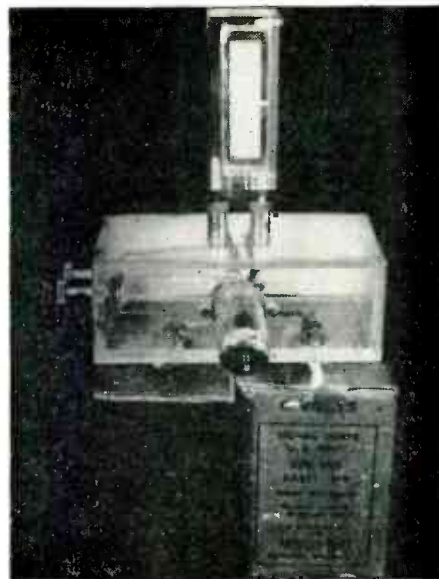

Simple oscillator produces up to 15 volts

Properly prepared ammonium dihydrogen phosphate and Rochelle salt crystals offer certain advantages over quartz in some applications in the frequency range from 10 to 150 kc. Softness and ease of handling frequently offset their comparatively large, but predictable, dependence on temperature

to  $\frac{1}{4}$  inch apart, and crystals wider than  $\frac{1}{2}$  inch should have three or more holes spaced  $\frac{1}{4}$  inch apart. Several sizes are shown in the photographs.

Synthetic crystals are soft enough that holes may be drilled through the crystal with an ordinary twist drill. Proper clearance is maintained if the hole is about 0.001 inch larger than the rod used for supporting the crystal. Nylon rods 0.025 inch in diameter have proved quite satisfactory in that they form a secure yet compliant support. A plastic tubing should be placed on the rods and mounted against the crystal to serve as a spacer between crystal and case. The rods then run through corresponding holes in the case. These holes serve both to center and support the crystals as shown in the closeup photograph. The electrical contact foil is secured by mounting it on the plastic rod between the crystal foil and the plastic spacer.

#### Crystal Circuits

Several tuned series-resonant oscillator circuits are shown in Fig. 2. From these circuits, one might

expect a very good wave form. The distortion level as measured on a General Radio distortion and noise meter is below 0.3 percent and is within the error range of the measuring instrument. The disadvantage in a tuned circuit is the change of circuit constants required for each crystal.

A series-resonant circuit suitable for wide-band application is shown in Fig. 3. This circuit will oscillate with any high-Q crystal whose resonant frequency lies between 10 kc and 150 kc. By balancing the d-c properly through the two tubes, it is possible to regulate the gain in such a manner that changes in B voltage cause negligible change in frequency. By reducing the gain of the system, it is possible to reduce the mechanical motion of the crystal to the point where oscillation is just maintained. This process reduces internal heating of the crystal and is very important in maintaining constant frequency.

The simplicity of a resistance-coupled circuit, using a synthetic crystal, is illustrated in the small photograph. Ordinarily the batteries will be replaced by a power

supply. From this circuit, an output voltage of 1 volt rms can be expected when a light drive is used. With heavier drives, it is possible to obtain as much as 15 volts of clean signal.

The maximum safe current that can be handled by the crystal is limited to the maximum elongation possible before rupture. This current  $I$  can be calculated for any bar expander since  $I = e b V Y$  where  $e$  is the piezo-stress constant,  $b$  the breadth of the crystal expressed in centimeters,  $V$  the phase velocity of sound,  $Y$  the breaking strain in the direction of elongation, and  $I$  is expressed in electrostatic units.

Crystal	$I$ (ma)
X-cut quartz	24 b
Y-cut RS	3.5 b
Z-cut ADP	10 b

The preceding tabulation gives a comparison of current between several crystals in terms of the width of the crystal. Again the thickness is not a factor in determining crystal parameters.

#### Frequency Stability

Experimental information on Rochelle salt and ammonium dihydro-

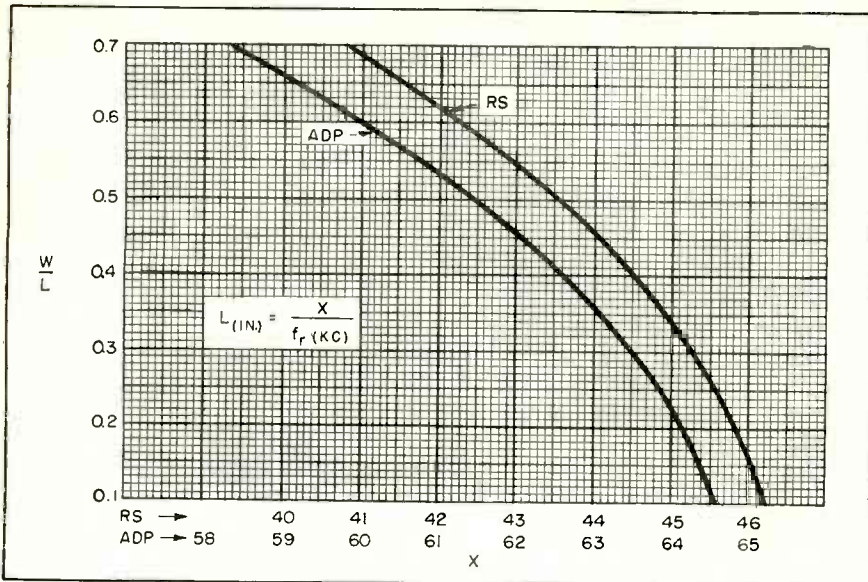

FIG. 1—Curves for determining physical dimensions of synthetic crystals must be read with extreme accuracy. Over-sized bars may be reduced with fine sandpaper

gen phosphate crystals indicates temperature is the greatest influencing factor in frequency stability. Variation in frequency with respect to temperature is linear in the range 25 C to 35 C. On the basis of the experimental figures and curve fitting, a formula was derived to permit the determination of change in frequency with change in temperature for both types in the range 10 to 150 kc. Results for both ADP and RS crystals are represented satisfactorily by

$$F = (0.0286 f_r + 1.8)^2$$

where  $F$  is the change in frequency in cycles per degree centigrade, and  $f_r$  is the resonant frequency in kilocycles. The data indicate one can expect a frequency stability within  $\pm 1$  cycle when the temperature is maintained within 0.1 C in the range below 50 kc. The greatest instability occurs at 150 kc where the resonance might be expected to change about  $3\frac{1}{2}$  cycles per 0.1 C change in temperature.

The next important factor limiting stability is the oscillator to which the crystal is attached. Experimental data have shown that when the circuit in Fig. 3 is balanced for d-c, it is possible to change the B voltage over a range of 2 to 1 with a corresponding change in frequency of less than one cycle per second. Change in filament voltage of 16 percent will cause a frequency shift of about

one cycle per second on a high frequency crystal.

From the information given here, it is possible to predict any frequency in the range 10 kc to 150 kc within  $\pm 10$  cycles at 24 C.

#### Typical Example

Suppose, for example, that we wish to design an ammonium dihydrogen phosphate crystal for a 30,000-cps oscillator, and we choose a width-to-length ratio of  $\frac{1}{3}$ . Interpolating on Fig. 1, for  $W/L = 0.333$ , we find  $X = 63.27$ . Then  $L = X/f_r = 63.27/30(\text{kc}) = 2.109$  inches, and  $W = L/3 = 2.109/3 = 0.703$  inch.

To determine the temperature stability we use the formula,  $F = (0.0286 f_r + 1.8)^2 = 7.1$  cycles per deg C.

An error of 0.01 in reading  $X$  will shift the resonance 4 cycles and an error of 0.001 in cutting the crystal to length can shift the resonance as much as 15 cycles. When the crystal is cut to the dimension calculated, its resonance at 24 C can be expected to lie between 29,990 and 30,010, and have a stability within  $7\frac{1}{2}$  cycles per degree temperature change.

Final adjustment is made by sanding and testing each crystal. Removing material from the end raises the frequency and cutting on the sides lowers the resonant frequency.

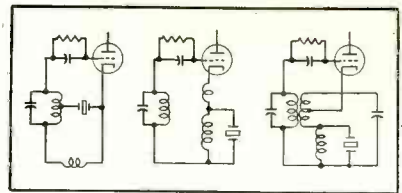

FIG. 2—Distortion level of output of these synthetic crystal oscillator circuits is below 0.3 percent

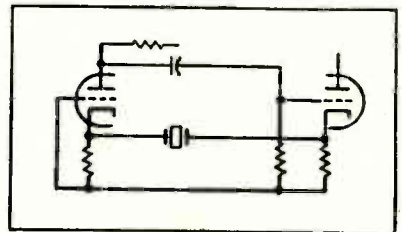

FIG. 3—This wide-band circuit will oscillate with any high-Q crystal from 10 to 150 kc

It is also important that the crystal have a high Q since the resonant frequency shifts as the crystal is loaded. A Q of 6,000 can be obtained when cemented foils are used and a Q of 15,000 is possible when evaporated foils are used. Evacuating the crystal holder thereby unloading the crystal will permit easily a Q of 30,000.

The electrical power required to drive these crystals is very small and it is recommended to keep this as low as practical for the reasons mentioned above. A good high-Q crystal will require about 80 microamperes at 200 millivolts or about 1.6 microwatts of crystal power.

When comparing synthetic crystals with quartz in the 10 to 150 kc range, each has its advantages depending upon the requirements of the problem. Aside from the softness and ease of handling advantages, synthetic crystals offer very favorable Q's in this range, with stability which is often more than sufficient. As to cost, Rochelle salt crystals cost from \$1.00 to \$1.50 each, and ammonium dihydrogen phosphate from \$2.00 to \$2.50 each. Gold plated foils will add about \$1.00 to the price of each crystal.

#### BIBLIOGRAPHY

- W. G. Cady, "Piezoelectricity," McGraw-Hill Book Co., New York, 1946.  
Butler, *Wireless Engineer*, 21, p 521, Nov. 1944.  
Butler, *Wireless Engineer*, 23, p 157, June 1946.





# STAMPING STANDARDS

METAL COMPONENTS . . . FOR METAL PLASTIC ASSEMBLIES  
. . . AND OTHER PARTS MADE TO SPECIAL REQUIREMENTS

For over a quarter of a century, Cinch small parts design and uses have kept pace with the need developed by the rapid changes in the Electronics Industry, so that today, judged by usage and performance, Cinch Metal plastic assemblies are considered Standard Components.



AVAILABLE AT LEADING  
ELECTRONIC JOBBERS EVERYWHERE



**Cinch**  
ELECTRONIC  
COMPONENTS

## CINCH MANUFACTURING CORPORATION

CHICAGO 24, ILLINOIS

Subsidiary of United-Carr Fastener Corporation - Cambridge 42, Massachusetts

# Equalizer Design Chart

Bass and treble attenuation or accentuation of two types of R-C equalizers for audio-frequency circuits are easily determined from the graph. Curves sketched from the chart resemble those computed laboriously point by point

By **CHARLES P. BOEGLI**

Cincinnati Research Company  
Cincinnati, Ohio

**F**OUR USES OF THE GRAPH are demonstrated by the examples. The entire range of characteristics is related to the quantity  $a$ , which is defined for each type of equalizer in Fig. 1 and 2.

An equalizer is to provide a treble drop of 3 db per octave beginning at 1,000 cps, operates

from a source resistance of 33,000 ohms.

**Solution.** For 3 db per octave,  $a = 0.33$ .  $R(1 - a) = 33,000$  whence  $R = 49,300$  and  $aR = 16,300$ . From the graph,  $f_1'/f_1 = 1.72$  so that  $f_1' = 1,720$  cps. At this frequency  $X_C = 49,300$  ohms, or  $C = 0.0019 \mu\text{f}$ . The high-frequency turnover is  $1000/0.111 = 9,000$  cps and the high-frequency level is down 9.6 db.

Find characteristics of equalizer consisting of series resistance of 48,000 ohms followed by

shunt of 18,000 ohms and a 0.001  $\mu\text{f}$  capacitor in series.

**Solution.** Total  $R = 66,000$  ohms. At  $f_1'$ ,  $X_C = 66,000$  ohms, or  $f_1' = 2,400$  cps;  $a = 0.273$  for which the graph shows a treble attenuation of 3.4 db per octave with  $f_1'/f_1 = 1.63$ ;  $f_1 = 1,470$  cps. Other data from the graph are the high-frequency turnover (14,200 cps) and the high-frequency level (down 11.3 db).

An equalizer for treble accentuation of 4 db per octave beginning at 5,000 cps is terminated by a 100,000-ohm grid resistor.

**Solution.** For 4 db per octave,  $a = 0.20$ .  $R/(1 - a) = 100,000$  whence  $R = 80,000$  ohms and  $R/a = 400,000$  ohms;  $f_1 = 5,000$  cps so  $f_1' = 7,450$  cps and  $f_2' = 37,250$  cps. Capacitor  $C$  has a reactance of 80,000 ohms at 37,250 cps;  $C = 53 \mu\text{f}$ .

Find the characteristics of an equalizer consisting of a series impedance of a 250- $\mu\text{f}$  capacitor paralleled by 1.5-megohms, this series impedance being followed by a shunt resistance of 222,000 ohms. This equalizer has been recommended for use with crystal pickups for commercial constant-velocity pressings.

**Solution.** Parallel resistance  $R$  is 193,000 ohms;  $f_2'$  is then 3,250 cps. Furthermore,  $193,000/(1 - a) = 222,000$  whence  $1 - a = 0.87$  and  $a = 0.13$ . The equalizer provides 4.7 db per octave treble boost with  $f_1'$  at 422 cps and  $f_1$  (the turnover frequency) at 313 cps. The low-frequency drop is 17.7 db.

As attenuation in db per octave decreases, the frequency range over which the equalizer is effective narrows.

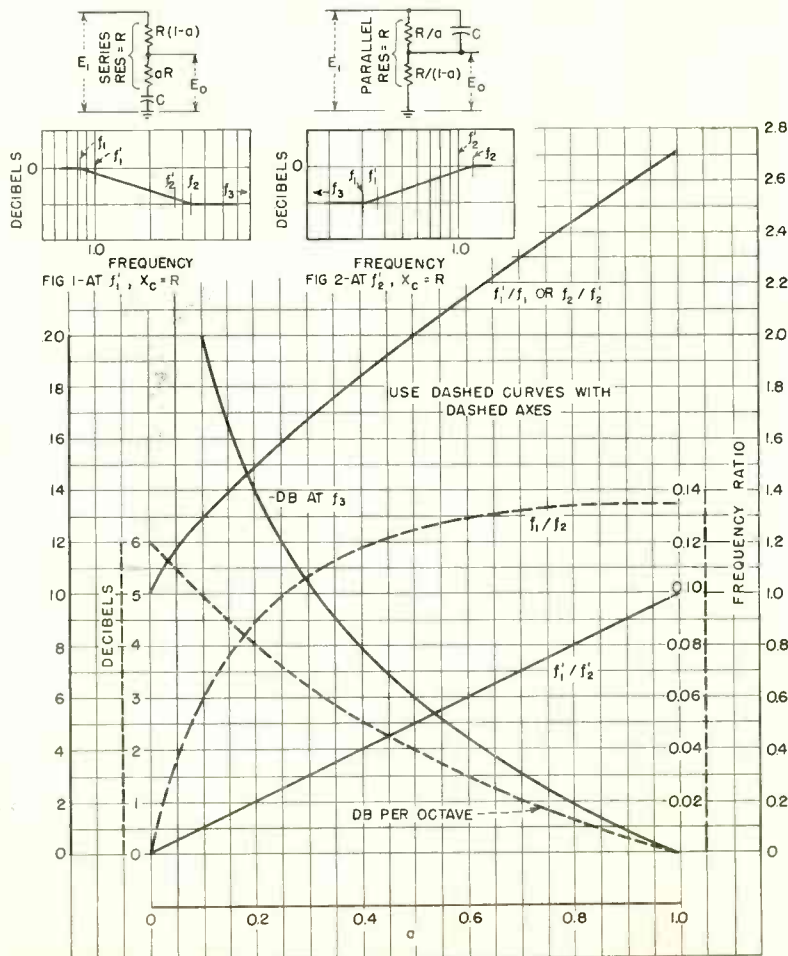



**Service  
Beyond  
Specifications!**

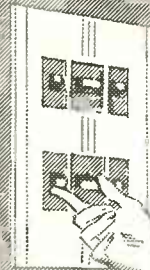

***Rush problems solved  
with Mallory Contacts  
and rapid-fire analysis!***

Mallory bridges the gap of time when customers signify a vital need for immediate attention.

Typical is the case of a manufacturer of electrical devices for household use . . . with a complex contact problem that had to be solved in a justifiable hurry. Within eight hours, Mallory's shirt-sleeve approach had accomplished the following: the device was reviewed and proper contact material specified . . . the contact design was modified for more economical production . . . costs were analyzed and quantity price was submitted.

At a later date, the customer received additional help . . . spectrographic analyses of materials other than contact materials, leading to further product improvement for this customer.

*That's service beyond specifications!*

This same Mallory service is available to anyone, whether the problem is electrical or metallurgical. What Mallory has done for others can be done for you!

*In Canada, made and sold by Johnson Matthey & Mallory, Ltd., 110 Industry St., Toronto 15, Ontario*

**Elkonite\* Contacts**

Elkonite is the trade name for a series of contact materials developed by Mallory and manufactured from metal powders. They are best known for their hardness, resistance to mechanical wear and impact, resistance to erosion by arcing, and resistance to sticking.

Elkonite contacts are made by the only method which permits the combining of the desirable features of basic metals which cannot be alloyed. By this means, the high melting points of tungsten, molybdenum, or their carbides, can be combined with the current-carrying ability of silver and copper.

**Electrical Contacts and Contact Assemblies**

\*Reg. U. S. Pat. Off.

**P. R. MALLORY & CO. Inc.**  
**MALLORY**  
**P. R. MALLORY & CO., Inc., INDIANAPOLIS 6, INDIANA**

- SERVING INDUSTRY WITH**
- Capacitors
  - Controls
  - Rectifiers
  - Special Switches
  - Contacts
  - Resistors
  - Vibrators
  - Power Supplies
  - Resistance Welding Materials

# TUBES AT WORK

Including INDUSTRIAL CONTROL

Edited by VIN ZELUFF

Navy Exhibits at IRE Engineering Show.....	116
Tachometer for Small Motors.....	118
One-Kilowatt Ultrasonic Generator.....	148
Simple Deviation Limiter.....	156
Computer Simulates Flight.....	164
British Television Relay.....	172
Shop Shortcuts.....	180

## Navy Exhibits at IRE Engineering Show

LATEST unclassified electronic equipment comprised the exhibit of the U. S. Navy prepared for the IRE winter meeting and shown to the press a few days before the show. Such gear is the joint responsibility of three bureaus of the Navy, the Bureau of Ships, Bureau of Aeronautics and the Bureau of Ordnance.

One of the toughest problems in modern radar design is how to keep the wave fronts accurately focused by the antenna. A secondary problem is how to make the radar waves visible for study. To help solve these problems, an electronically driven ripple tank was exhibited by the Naval Research Laboratory.

Water ripples are used for the

qualitative and semi-quantitative study of phase fronts near two-dimensional models of antenna structures. Electronically driven probe-vibrators are used to excite the water surface of a glass ripple tank. Synchronously chopped light is directed through the tank to a ground-glass screen where the phase front shadow patterns appear stationary. Thus, it is possible to view the changes in phase-front patterns brought about by changes in feed point position and in reflector configuration, as well as by changes of as much as several hundred percent in exciting frequency.

The Naval Ordnance Laboratory displayed a new type of magnetic material called orthonol. This ma-

terial, developed by Naval Observatory Laboratory, is used for making coils for a magnetic amplifier on display.

The magnetic servo amplifier contains only coils wound on orthonol and metallic rectifiers. For purposes of demonstration it points a toy gun mount at a submarine whenever it exposes itself at the surface of a table simulating water. When the submarine surfaces, an impulse is supplied to the magnetic servo amplifier. The amplifier magnetically magnifies this impulse one-million times (power) and this output signal aims the gun at the surfaced submarine. The power output of the magnetic amplifier is 20 watts.

A telegraph test set was shown which is used for testing telegraph equipment and telegraph communications circuits. Its precision is such that any differential in the received and transmitted signals provides an indication of the quality and character of the equipment or circuit under test. The gear consists of a photoelectric signal generator, a recorder and a power supply for the recorder.

The signal generator originates precise square waves which are applied to the telegraph equipment or communications circuit under test. The recorder simultaneously receives the telegraph signal from the equipment or circuit under test. The test signal generated is repetitive in character, each repetitive

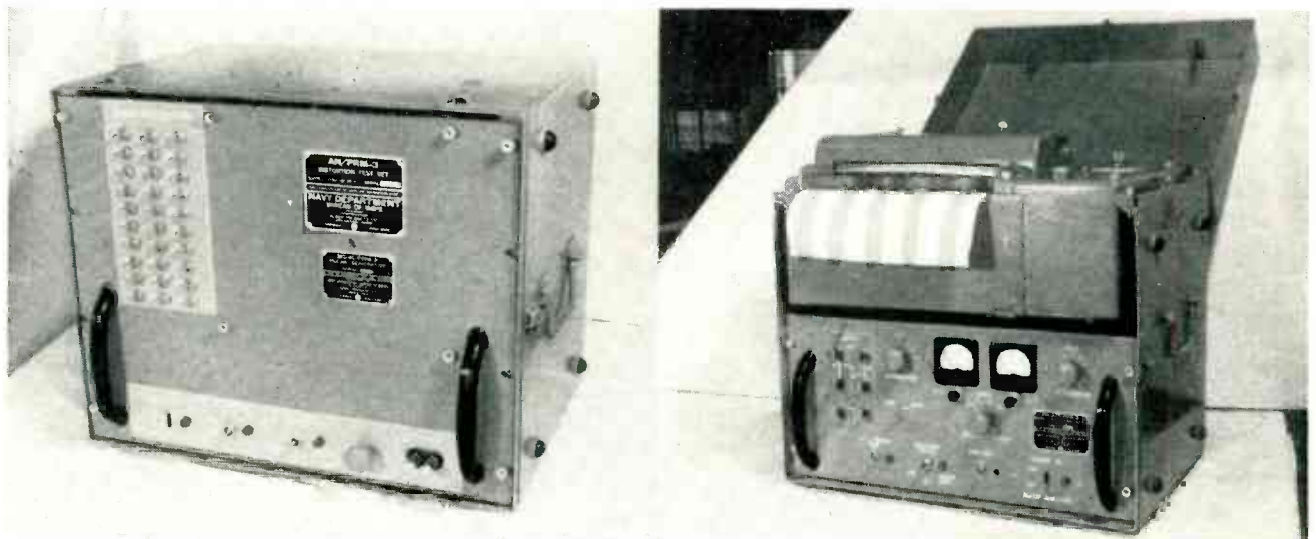

Pulse generator, left, and recorder, right, of the telegraph distortion test set. Time signals or bauds are set up on the 30 switches of the generator which control lights of a photoelectric commutator. Any 10 consecutive bauds appear on the recorder at right as dark areas for mark and light areas for space signals





# A Masterpiece

**COMPLEX, EFFICIENT . . . KESTER SOLDER MAKES IT POSSIBLE**

Good fast work can only be done with the best materials. Kester Plastic Rosin-Core Solder and the more active Kester "Resin-Five" Core Solder, made only from newly mined grade A Tin and Virgin Lead, are formulated especially for TV, radio, and electrical work. Kester Solders flow better . . . handle easier . . . faster to use.

Free Technical Manual—Send for your copy of "SOLDER and Soldering Technique."

**KESTER SOLDER COMPANY**

4204 Wrightwood Ave., Chicago 39, Ill.  
Newark, N. J. • Brantford, Canada



SAVES TIME

DEPENDABLE

EASIER TO USE

FASTER



## THE FRONT COVER

**U**SE of electronic motor control for capacitor winding avoids breakage of either foil or paper when the machine is started several times during the winding operation. It also materially increases the speed with which the capacitor sections can be successfully wound. Because of the smooth control provided by the Westinghouse unit, the aluminum-foil thickness is now governed by electrical requirements only and much thinner foil can be used, contributing to reduction in capacitor weight and size.

cycle consisting of a minimum of 30 bauds, each of which can be made to represent either a marking or spacing condition at the will of the operator by operation of toggle switches on the control panel. The cycle is made to repeat itself at the rate at which lines are scanned on the recorder.

### Wind-Tunnel Strain Gage

Many tests in supersonic wind tunnels at the Naval Ordnance Laboratory require the measurement of the aerodynamic forces and moments on a model subjected to the wind-tunnel air flow. It is desirable that the transducer have rapid response and give a force reading in a second or two after the tunnel has been turned on.

Because some of the NOL tunnels are of the intermittent type, a short blowing time allows more runs to be made per hour, leading to a greater tunnel efficiency. The intermittent feature lends itself well to the use of strain gages as sensitive elements since a zero reading can be obtained before and after the force measurement has been made, and within a few seconds of it.

The equipment on exhibit has been designed to be used with internal strain-gage balances. It consists essentially of a balancing and calibrating circuit, an amplifier, an output circuit, an oscillator, and a cathode-ray null indicator. Commercially available units are used wherever possible. Two channels are provided in a single console, but a number of consoles may be connected together when additional channels are required.

The oscillator frequency may be set at either 400 or 2,000 cycles per second, and the voltage applied to the strain-gage bridge may be adjusted between 1 and 5 volts. The

smallest measurable strain is approximately 0.1 microinch per inch when used with four active gages in a full bridge circuit.

The latest development in Navy teletypewriter equipment is an electronic time-division multiplex telegraph terminal consisting of two sets, a telegraph transmitting unit, and a telegraph receiving unit.

The teletype transmitting unit accepts on-off d-c start-stop signals from local transmitting circuits, converts them to multiplex signals and applies these in sequential order, channel-by-channel, to the telegraph circuit. The signals are then delivered to the distant receiving group which accepts similar multiplex signals and converts them to start-stop signals and then transmits the start-stop signals in their original on-off d-c form to the proper local receiving circuit.

The set is capable of supplying a maximum of four channels from any one telegraph circuit at a speed of either 60 or 75 wpm. The transmitting and receiving groups, cycling at identical rates of speed, operate in synchronism at all times and are held in synchronism by a crystal-controlled oscillator.

This equipment has many features which make it highly desirable for Navy use. Once the transmitter and receiver have been synchronized they will remain so from one to one and one-half hours with the telegraph circuit disconnected. If either the receiving or transmitting circuit is inadvertently broken, there is both a visual and an audible warning signal.

The Naval Air Development Center at Johnsville, Pennsylvania, exhibited several subminiature assemblies. One of these is an eight-stage video amplifier having a bandwidth of 2.5 megacycles. The



Shadow patterns of phase fronts near tiny models of antenna structures are shown on ground glass screen of this ripple tank

voltage gain of the amplifier is approximately 50,000 and the output is a 30-volt pulse 2 microseconds wide, with a rise time of about 0.15 microsecond.

Also exhibited by the Navy were the latest in ultra-high-frequency transmitting and receiving equipment; a tilting table to demonstrate the action of radar antenna stabilization under actual operation; one of the standard fleet-installed ppi units for remote presentation of information received on various shipboard radars; a setup of microwave oscillators and horn antennas like that in a shooting gallery to show the reflection of the waves from certain types of dielectric radomes; an infrared telephone transmitter and receiver and a radar beacon circuit that adds only four pounds to the normal radar equipment of a fighter aircraft.

## Tachometer for Small Motors

BY LOWRIE B. SARGENT, JR.  
Aluminum Research Lab.  
Aluminum Co. of America  
New Kensington, Pa.

AND WAYNE WEBB  
Department of Physics  
The Pennsylvania State College  
State College, Pa.

FOR high-pressure viscosity measurements it was necessary to design and to construct a tachometer for measuring the rotational speed

(continued on p 134)



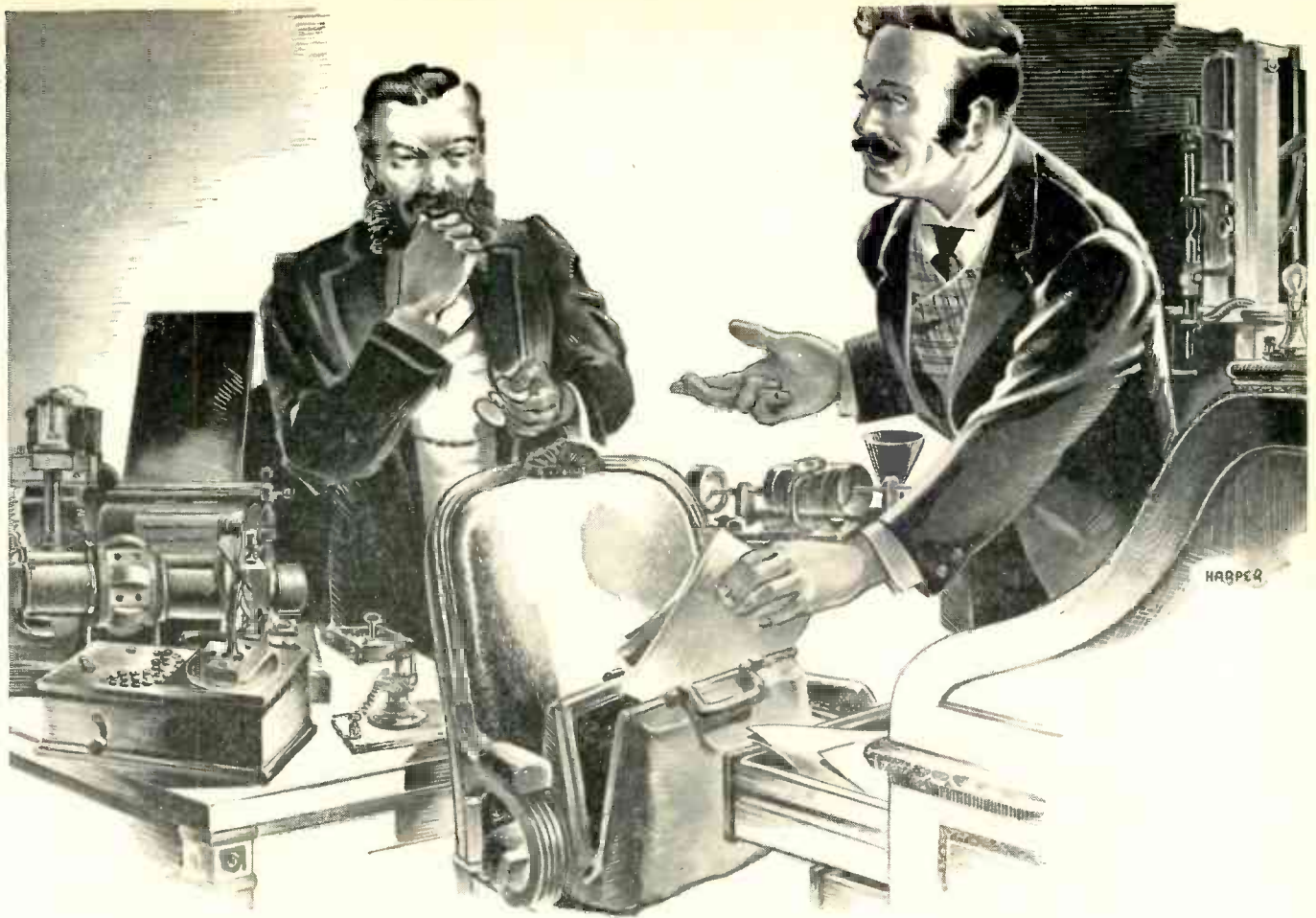

## The mistaken young man who quit the patent office . . .

Back in the 1880's, a young man quit the patent office. It was a perfectly good job except for one thing: There wasn't any future in it. You could, as he explained, walk through the place and see for yourself that just about every possible thing had been invented.

He was, of course, just as wrong then as he would be today almost seventy years later. In a world where nothing is impos-

sible and many things are still unknown, progress is limited largely by lack of imagination.

In electronics alone, a "normal" quarter of a century's development has been crowded into the past half dozen years. And patent requirements of this single industry probably equal the total work of the patent office when this mistaken young fellow resigned.

# SPRAGUE

**SPRAGUE ELECTRIC COMPANY**  
North Adams Massachusetts

PIONEERS IN

ELECTRIC AND ELECTRONIC DEVELOPMENT

Sprague Telecaps\*, the first truly practical phenolic molded paper tubulars, introduced a new era in trouble-free small capacitor performance, whether under "normal" or exceptionally difficult operating or "shelf" conditions.

\*T.M. registered



Revolutionary new dry electrolytic capacitors to match television's exacting needs are another Sprague pioneering development. Conservatively rated up to 450 volts at 85°C., these long-life electrolytics are outstandingly stable.



Sprague Subminiature Paper Capacitors, hermetically sealed in metal cases with glass-to-metal solder-seal terminals, are designed to be as good as, and often better than, larger units.



# THE ELECTRON ART

Edited by JAMES D. FAHNESTOCK

Clocking Meteors by C-W Radar.....	120
Strip Chart Recording with An Autoscaler.....	122
Magnetic Modulation of Phototube Currents.....	184
Study of Skin Impedance.....	190
Resistor Behavior At High Frequencies.....	196
Wide-Range Electrostatic Generating Voltmeters.....	200
Aluminum Fins for Tubes.....	206
Voice-Operated Busy Signal.....	208
Survey of New Techniques.....	212

## Clocking Meteors by C-W Radar

BY OSWALD G. VILLARD, JR.  
*Department of Electrical Engineering  
Stanford University, California*

A CONTINUOUS-WAVE radar technique for measuring meteor speeds has been developed at Stanford University, California. A c-w transmitter located on the campus radiates a signal directed vertically upward. Reflections from ionization columns created by the passage of meteors through the E region of the ionosphere are received on standard communications receivers located in a shielded valley about 4 miles away.

Overloading of the receivers by the local transmitter is prevented by a ground-wave cancellation system in which a strong signal from

the transmitter is picked up in a directive antenna located outside the valley, attenuated, shifted in phase, and fed to the receivers through a coaxial cable. This reference signal is substantially free of superimposed meteoric reflections because it is picked up in an antenna having very low sensitivity to signals arriving at vertical angles appreciably above the horizontal. Ground-wave leakage at the receiving site can be reduced by 20 decibels with good stability by this means.

In practice, a small amount of ground wave is allowed to leak



Continuous-wave meteor recording apparatus permits study of swarms of meteors too small for photographic recording

through in order to beat with meteor-reflected signals. These reflections are Doppler-shifted in frequency due to the speed of the meteor relative to the observer. Owing to the beat with the ground wave, meteors announce themselves by audible whistles of descending pitch, not unlike the whine of a falling bomb. A recording of the whistle, together with a measurement of the slant range to the ion column when it crosses the perpendicular with respect to the observer when the whistle falls to zero pitch yields the speed of the meteor to a high degree of accuracy. Meteor showers provide a means for checking the accuracy of radio detection methods, since shower meteors travel at virtually a constant speed which is known to a high degree of precision in the case of the major annual showers.

It has been found that the ion columns form at a rate equal to the speed of the meteors, and not at a lower rate, as had been suspected. This conclusion has been confirmed at radio frequencies as low as 6 megacycles, and suggests that at least part of the mechanism by which columns are formed is akin to radiation—perhaps ultraviolet light—emanating from the tiny (pea-sized) meteoric particles themselves.

The continuous-wave radio speed-measuring technique is vastly more sensitive than the photographic methods previously available to astronomers. During a typical



Receiving station for continuous-wave meteor clocking setup developed at Stanford University. Receiver overloading is prevented by a ground-wave cancellation system



# For Telemetering

## NEW

### SIGNAL GENERATOR TYPE 202-D

Frequency Range 175—250 mc



The Type 202-D Signal Generator, developed to meet the specialized requirements of engineers working with telemetering receivers and other associated equipment, will be welcomed by many who have long needed a precise and reliable instrument for rapidly evaluating overall system performance.

#### SPECIFICATIONS:

**RF RANGE:** 175–250 megacycles in one range, accurate to  $\pm 0.5\%$ .

Main frequency dial also calibrated in 24 equal divisions for use with vernier frequency dial.

**VERNIER FREQUENCY DIAL:** This dial is divided into approximately 100 equal scale divisions and is coupled to the main frequency dial by a 24:1 gear train. The approximate frequency change per vernier division is 35 kc.

**FREQUENCY MODULATION (DEVIATION):** The FM deviation is continuously variable from zero to 240 kc. The modulation meter is calibrated in three FM ranges (1) 0–24 kc., (2) 0–80 kc., and (3) 0–240 kc. deviation.

**AMPLITUDE MODULATION:** Utilizing the internal audio oscillator amplitude modulation may be obtained over the range of 0–50% with meter calibration points of 30% and 50%. By means of an external audio oscillator the RF carrier may be amplitude modulated to substantially 100%. A front panel jack is provided which permits direct connection of an external modulating voltage source to the final stage for pulse and square wave modulation. Under these conditions the rise time of the modulated carrier is less than 0.25 microseconds and the decay time less than 0.8 microseconds.

**MODULATION CONTROLS:** Separate potentiometers are provided for continuous control of FM and AM levels.

**MODULATING OSCILLATOR:** The internal AF oscillator may be switched to provide either frequency or amplitude modulation.

It may also be switched off. Eight fixed frequencies between 50 cycles and 15 kilocycles are available, any one of which may be selected by a rotary type switch.

**RF OUTPUT VOLTAGE:** The RF output voltage is continuously variable over a range from 0.1 microvolt to 0.2 volts at the terminals of the output cable. The impedance of the RF output jack, looking into the instrument, is 53 ohms resistive.

**DISTORTION: FM:** The overall FM distortion at 75 kc. is less than 2% and at 240 kc. less than 10%.

**AM:** The distortion present at the RF output for 30% amplitude modulation is less than 3% and for 50% AM less than 6.5. At 100% the distortion is 12% to 15% depending upon the modulating frequency.

**SPURIOUS RF OUTPUT:** All spurious RF output voltages are at least 25 db. below the desired fundamental. Total RMS spurious FM from the 60 cycles power source is down more than 50 db., with 75 kc. deviation as a reference level.

#### EXTERNAL MODULATION REQUIREMENTS:

**Frequency Modulation:** The deviation sensitivity is 50 kc. per volt. For external FM the input impedance is 1500 ohms.

**Amplitude Modulation:** Approximately 45 volts are required for 50% modulation and 100 volts for 100% modulation. For external AM the input impedance is 7500 ohms.

**Audio Voltage for External Use:** There is available at the FM external oscillator binding posts about 5 volts a.c. maximum and at the AM external oscillator binding posts, 50 volts maximum.

**DIMENSIONS AND WEIGHT:** Outside cabinet dimensions: 17" high, 13½" wide, 11½" deep. Weight: 35 pounds.

PRICE AND DELIVERY INFORMATION FURNISHED UPON REQUEST

**BOONTON RADIO**  
BOONTON · N.J. · U.S.A. Corporation



DESIGNERS AND MANUFACTURERS OF THE Q METER · QX CHECKER  
FREQUENCY MODULATED SIGNAL GENERATOR · BEAT FREQUENCY  
GENERATOR AND OTHER DIRECT READING INSTRUMENTS

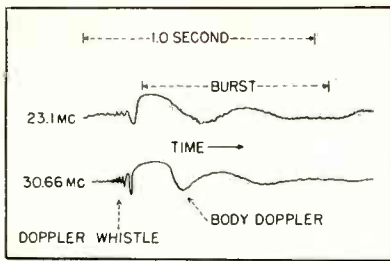

Typical meteor echo recorded at two radio frequencies. From the rate of frequency change in Doppler whistle, and a measurement of slant range, the speed of the meteor can be measured with good accuracy

night, on which a visual observer might see perhaps 100 meteors, 500 to 1,000 meteor speeds may be ob-

tained with a radiated power of the order of one kilowatt. A shower may be expected to increase this number several-fold. Estimated to be 10,000 times as sensitive as the best astronomical cameras available in the past, and considerably more sensitive (owing to bandwidth and average power considerations) than radio speed-measuring techniques depending on pulsed transmissions, the continuous-wave method makes possible study of the speed characteristics of swarms of meteors too small to register on a photographic plate.

The results of a large-scale investigation using this method, now being carried out by the National

Research Council in Canada, should settle a question long current in astronomical circles, whether certain of the meteors originate outside our solar system, and thus might be expected to provide a clue to the makeup of other solar systems. Visual observations made in the past, admittedly less accurate than electronic measurements, seemed to support such a conclusion. The radio method will provide the answer for meteors down to the 8th or 9th visual magnitudes.

#### BIBLIOGRAPHY

L. A. Manning, O. G. Villard, Jr. and A. M. Peterson, Radio Doppler Investigation of Meteoric Heights and Velocities, *Journal Applied Physics*, 20, p 475, May 1949.

## Strip Chart Recording with An Autoscaler

BY S. W. LICHTMAN, E. T. BYRAM  
AND H. FRIEDMAN

*U. S. Naval Research Laboratory  
Washington, D. C.*

GEIGER COUNTERS are usually employed in combination with counting circuits which register either the number of counts accumulated in a given time or the time required to accumulate a predetermined count, or with rate meter circuits which present the integrated counting rate continuously as a meter deflection. The latter method has the advantage that it can be used with strip-chart recording. Depending on the counting rate and its rate of variation, experience has shown that it is ordinarily preferable to use either one or the other type of counting.

The method of count interval recording described here is an attempt to combine the desirable features of both the direct counting method and the rate meter strip chart type of recording. It also provides a simple means of obtaining reciprocal, logarithmic, or other compressed scales to cover a wide range of counting rates.

#### Count Interval System

The method consists of controlling the current through a recording meter by means of a synchronous motor-driven potentiometer.

The running time of the motor is controlled by a scaling circuit arranged to stop automatically after a predetermined count. The motor begins to drive the potentiometer at the inception of counting and runs for the duration of the counting interval. When the specified count is reached, the potentiometer is restored rapidly to its zero position. A relay then restarts the scaling circuit and initiates a new counting interval.

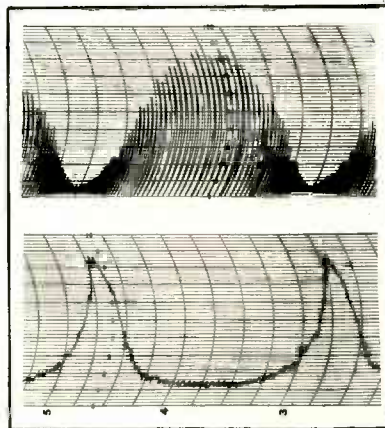

FIG. 1—At top, the recording meter measures voltage, and the envelope of the end points varies inversely as the counting rate meter curve below. Charting speed is 12 inches per hour

If the recording meter measures the voltage output of the potentiometer, the envelope of the end points varies inversely as the counting rate, as in Fig. 1. Alternatively, if the meter is inserted in series with the variable resistor element and a constant source of voltage, the envelope of the end points traced will vary directly with the counting rate. Either a linear or a compressed deflection versus time is obtained by selecting a linear potentiometer or one with a suitable taper, such as a logarithmic potentiometer.

One type of clock-driven potentiometer assembly is shown in the photograph of Fig. 2. It comprises a synchronous clock motor with a spiral restoring spring, geared to the control potentiometer. Also shown in the photograph is a snap-switch mounted directly above the gearing. The switch is normally opened, but is closed momentarily at the end of the fly-back period by means of a cam attached to the drive shaft, thereby restarting the scaling circuit. The particular unit of Fig. 2 produced a full rotation in

(Continued on page 184)



# HEINEMANN MAGNETIC CIRCUIT BREAKERS

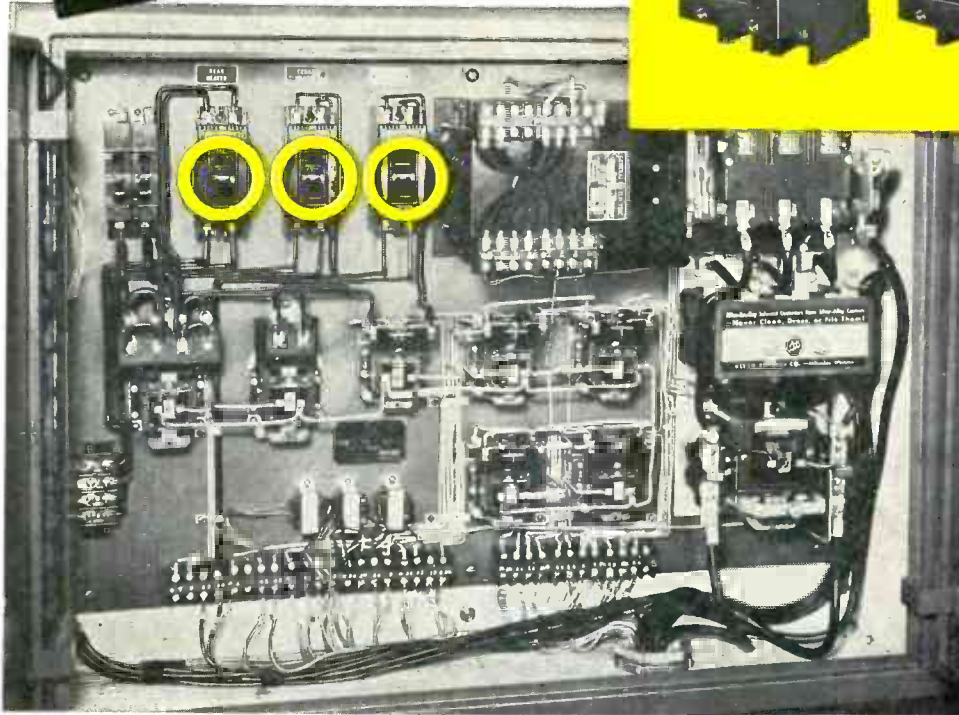

Control Panel for Plastic Injection Molding Machine  
Showing Position of Circuit Breakers

in this

## REED-PRENTICE

Control Panel  
guarantee

## DEPENDABLE

FLEXIBLE

## PROTECTION

for electrical  
circuits

**1** **DEPENDABLE**—Because Heinemann Magnetic Circuit Breakers act on the magnetic principle—the overload itself makes a magnetic field around the trip unit which INSTANTLY opens the breaker. NO WAITING for thermal units to heat. No damage can be done.

**2** **FLEXIBLE**—Because a Time-Delay Unit, pre-calibrated at the factory to meet YOUR specifications, prevents the breaker from tripping on minor overload or starting surge. These circuit breakers are available with any one of three different inverse time delays.

Handle is plainly marked in "ON" and "OFF" position.  
Breakers are listed by Underwriters Laboratory

Send For Bulletin With Complete Description



# HEINEMANN ELECTRIC COMPANY

97 PLUM STREET

TRENTON, NEW JERSEY

# NEW PRODUCTS

EDITED by WILLIAM P. O'BRIEN

**Emphasis on Controls and Meters Points Up Ever-Expanding Use of Electronics in Industry . . . Trend Is Toward Further Miniaturization of Tubes and Components . . . Six Columns of New Literature**



## Voltage Regulator

ACME ELECTRIC CORP., Cuba, N. Y., has developed the Voltrol for testing electrical and electronic components and finished products on ranges between 70 and 130 volts. The unit is basically a specially constructed transformer with windings that are individually tapped at each turn. Regulation is accurate to 0.4-volt adjustment and output voltage is practically independent of the load. Size of the unit is 10½ in. × 6½ in. × 6½ in. Weight is 15½ lb.



## Speed Measuring Device

KAY ELECTRIC Co., Pine Brook, N. J. The Rotalyzer measures average rotational speed of a shaft and indicates variations in speed vs time. A high-frequency magnetic

disc and pickup are employed on the shaft to be measured. The equipment, as supplied, includes the necessary pickup devices, a cabinet containing the electronic amplifier and analyzer elements and an oscilloscope. Standard speed range of the Rotalyzer is 900 to 7,200 rpm. Accuracy of 0.1 percent is available over the speed range.



## Smaller Paper Tubulars

AEROVOX CORP., New Bedford, Mass., have introduced type P85 miniature paper tubular capacitors. The paper section is Aerolene-impregnated and the capacitor is sealed with Duranite. The new units can be used at 212 F without drips. Dielectric strength is maintained at elevated temperatures.



## Laboratory Power Supply

HEWLETT-PACKARD Co., 395 Page Mill Rd., Palo Alto, Calif. The

model 712A power supply provides variable d-c voltages from 0 to 500 volts at 200 ma; with 0.5-percent regulation. It also makes available 0 to 150 volts for bias use, plus 10 amperes a-c at 6.3 volts. Meters are provided to monitor voltages and currents. The unit is designed for flexibility, compactness and portability.



## Self-Excited Chopper

STEVENS-ARNOLD INC., 22 Elkins St., South Boston, Mass., has developed a self-excited chopper which will operate from d-c. It offers modulation and demodulation in the one unit. Nominal ratings are 10 volts, 0.001 ampere d-c, but these may be exceeded, on an intermittent basis, as required in servomechanism applications. The chopper is particularly well suited for use in aircraft where there is a d-c as well as an a-c power source to choose from.



## High-Voltage Probe

ELECTRONICS INSTRUMENT Co., 276 Newport St., Brooklyn, N. Y. Model HVP-1 high-voltage probe for television servicing measures up to 30,000 volts. It uses a special helical film, steatite rod type, removable multiplier resistor. The probe



# HE COULDN'T GET ALONG WITHOUT RAYTHEON SUBMINIATURE TUBES CAN YOU?



Today, nobody would dream of designing walkie-talkies or weather balloon equipment or hearing aids without SUBMINIATURE TUBES.



Stop and think! Aren't the qualities that make Subminiatures invaluable for these exacting jobs exactly what the doctor ordered for *your* equipment?

RAYTHEON Flat Press Subminiatures are the exception that proves the rule. They're the "small boy" that does a man's work. Rugged, long lasting, more dependable and efficient than their larger tube counterparts, they increase product acceptance. They fit standard sockets or can be soldered or welded into the circuit. Over 300 Raytheon Distributors stock them and are conveniently available to serve you. Raytheon Subminiatures are standard the world over — *more in use than all other makes combined.*

This chart gives you at a glance the characteristics of representative Raytheon Subminiature Tubes

Type No.	Remarks	Maximum Diameter Inches	Maximum Length Inches	Filament Or Heater		Mutual Conductance umhos	Power Output MW	TYPICAL OPERATING CONDITIONS				Grid Volts
				Volts	Ma.			Plate	Ma.	Screen	Ma.	
<b>HEATER CATHODE TYPES</b>												
CK5702/CK605CX	Characteristics of 6AK5	0.400	1.5	6.3	200	5000		120	7.5	120	2.5	0
CK5703/CK608CX	Triode, UHF Oscillator, 3/4 watts at 500 Mc	0.400	1.5	6.3	200	5000		120	9.0			Rk = 220
CK5704/CK6068X	Diode, equivalent to one-half 6AL5	0.315	1.5	6.3	150			150ac	9.0			
CK5744/CK619CX	Triode, High mu.	0.400	1.5	6.3	200	4000		250	4.0			Rk = 500
CK5784	Characteristics of 6AS6	0.400	1.5	6.3	200	3200		120	5.2	120	3.5	-2.0
CK5829	Similar to 6AL5	0.300x0.400	1.5	6.3	150			117ac	5.0 per section			
<b>FILAMENT TYPES</b>												
1AD4	Shielded RF Pentode — High Gm	0.300x0.400	1.5	1.25	100	2000		45.0	3.0	45.0	0.8	0
CK571AX	10 ma. Filament electrometer tube, I <sub>g</sub> = 2x10 <sup>-11</sup> amps.	0.265x0.400	1.5	1.25	10	1.61		10.5	0.20			-3.0
CK573AX	Triode, high frequency output	0.300x0.400	1.5	1.25	200	2000		90.0	11.0			-4.0
CK574AX	Shielded Pentode RF Amplifier	0.290x0.390	1.25	0.625	20	37†		22.5	0.125	22.5	0.04	-0.625
CK5672	Output Pentode	0.285x0.385	1.5	1.25	50	625	60.0	67.5	2.75	67.5	1.1	-6.25
CK5676/CK556AX	Triode, UHF Oscillator for radio use	0.300x0.400	1.5	1.25	120	1600		135.0	4.0			-5.0
CK5677/CK568AX	Triode, UHF Oscillator for radio use	0.300x0.400	1.5	1.25	60	650		135.0	1.9			-6.0
CK5678/CK569AX	RF Pentode	0.300x0.400	1.5	1.25	50	1100		67.5	1.8	67.5	0.48	0
CK5697/CK570AX	Electrometer Triode Max. grid current 5x10 <sup>-12</sup> amps.	0.285x0.400	1.25	0.625	20	1.5†		12	0.22			-3.0
CK5785	High voltage rectifier	0.285x0.400	1.5	1.25	15				0.1			Inverse peak 3500 volts
<b>VOLTAGE REGULATORS</b>												
CK5783	Voltage reference tube — like 5651	0.400	1.63									
CK5787	Voltage regulator	0.400	2.06									

CK ® RK ®

†Voltage Gain Ratio.

**RAYTHEON**

*Excellence in Electronics*

**RAYTHEON  
MANUFACTURING  
COMPANY**

**SPECIAL TUBE SECTION  
Newton 58, Massachusetts**

**SUBMINIATURE TUBES  
GERMANIUM DIODES  
and TRIODES  
RADIATION COUNTER TUBES  
RUGGED, LONG LIFE TUBES**

matches most 20,000-ohm-per-volt meters as well as most vtvm's now in use.



### Small Volt-Ohmmeter

SIMPSON ELECTRIC Co., 5200-18 W. Kinzie St., Chicago, Ill. Model 303 vacuum-tube volt-ohmmeter for television servicing is only 120 cubic inches in size. Its d-c input resistance is 10 megohms for all ranges. The unit has five d-c and five a-c voltage ranges, five resistance ranges, three a-f voltage ranges, decibels from -20 to +63 in five ranges, a zero center galvanometer for f-m discriminator alignment and other galvanometer applications, and an r-f voltage range with 20 volts maximum and flat frequency measurements between 20 kc and 100 mc.

volt will produce one-inch deflection on vertical and horizontal axes, respectively. The instrument's gas-triode linear time-base generator provides recurrent sweep frequencies from 8 to 30,000 cps, synchronized with either the vertical amplifier or some external source.



### Rectangular Picture Tube

HYTRON RADIO & ELECTRONICS CORP., Salem, Mass. Type 16RP4 is a direct-view all-glass, 16-in. picture tube with a rectangular screen. It takes approximately the same cabinet space as a round 12-inch picture tube. The picture, with standard 3 by 4 aspect ratio, has a usable screen area of 138.7 sq in. A neutral gray face increases the contrast ratio.

low impedance at high-frequencies. Overall dimensions including mounting foot are 1 1/4 in. x 7/8 in.

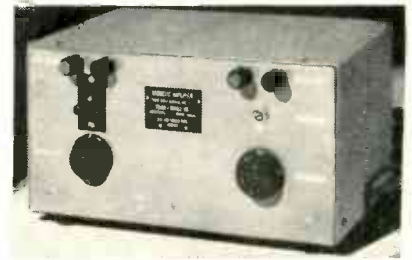

### Magnetic Amplifier

TRANS-SONICS, INC., Bedford Airport, Bedford, Mass. Type 63-1 magnetic amplifier is intended for use in measurements and control and, when used with thermocouples or strain gage pickups, makes possible the recording of temperature, pressure and accelerations on standard recording millimeters. Gain is constant to  $\pm \frac{1}{2}$  percent with a  $\pm 10$ -percent change in line voltage, and zero drift over a period of several weeks is less than  $\pm 50 \mu\text{v}$  referred to the input terminals. Power line is 117 volts, 60 cycles. Maximum output current is 300 ma.



### Portable Oscilloscope

ALLEN B. DU MONT LABORATORIES, INC., 1000 Main Ave., Clifton, N. J. Type 292 three-inch c-r oscilloscope weighs only 21 pounds. Input signals of 0.4 rms volt and 0.56 rms

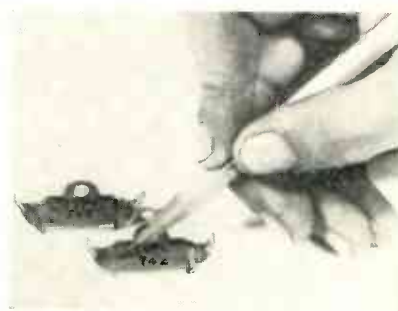

### Mica Capacitors

CORNELL-DUBILIER ELECTRIC CORP., South Plainfield, N. J. Type 742 series of feedthrough mica capacitors was designed for use in auto-radio receivers for radio noise bypass. They are also useful in f-m and tv equipment because their feedthrough construction provides



### Ionization Gage Control Circuit

DISTILLATION PRODUCTS INDUSTRIES, Ridge Road West, Rochester 3, N. Y. The DPA-38 ionization gage control circuit was designed for measuring the highest vacua attainable. It is particularly useful in determining the difficult ranges below  $10^{-7}$  mm Hg. The lowest scale division represents  $2 \times 10^{-9}$  mm Hg. The new circuit features a direct-reading scale where the negative exponent of the number of milli-

(Continued on page 214)



# Team Mates...



## ...for mobile communications

HERE ARE TWO unbeatable VHF power tube combinations for mobile transmitter designs where high efficiency and extreme compactness are paramount requirements. All four of these RCA-developed tubes have high power gain and may therefore be operated at relatively low plate voltage to provide large power output with small driving power.

The RCA-5763 miniature type beam power tube is very suitable as an output stage of low-power mobile transmitters and as a doubler or tripler in higher-power units. It can be operated with full input up to 175 Mc. The RCA-2E26 is intended primarily for use in the driver stages or the output stage of emergency mobile or FM transmitters. It can be operated with full input up to 125 Mc. and will provide an output of about 13 watts at 160 Mc.

The RCA-5618 power pentode and the RCA-2E24 beam power tube are quick-heating types with low fila-

ment drain, and are particularly suitable for mobile and emergency-communications transmitters where the operating power supply must be kept small. Both types are designed for intermittent operation. The RCA-5618 is superior as a doubler or tripler; the RCA-2E24, as the final amplifier in low-power FM transmitters.

Already proved in thousands of installations, these RCA tubes can be depended upon for their quality, ruggedness, and superior performance.

**RCA Application Engineers** are ready to work with you in applying any of these or other RCA tube types to your specific designs. For further information write RCA, Commercial Engineering, Section D42R, Harrison, New Jersey.

RCA Laboratories, Princeton, N. J.

THE FOUNTAINHEAD OF  
MODERN TUBE DEVELOPMENT IS RCA



### RADIO CORPORATION of AMERICA

ELECTRON TUBES

HARRISON, N. J.

# NEWS OF THE INDUSTRY

Edited by WILLIAM P. O'BRIEN

## New Trainer for High-Speed Flight

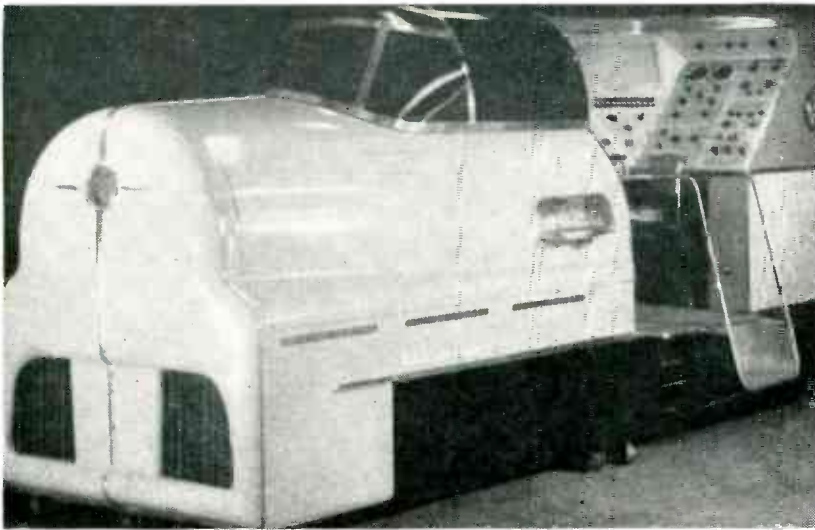

The electronic jet trainer combines pilot and instructor positions in one unit. Record of the pilot's ground track is drawn on aeronautical chart

A JET pilot-trainer recently delivered to the U. S. Air Force by Link Aviation Corp. simulates new problems introduced in actual flight by increased aircraft speeds and improved electronic aids to air navigation.

The unit combining flight, engine and navigation problems is self-contained for both pilot and instructor, but can be separated into four sections for transportation or movement through standard doorways.

Besides standard communications and navigation simulators, the new trainer includes GCA, ILS, omnirange, offset course computer and similar facilities just coming into use under the ANDB interim program (see *ELECTRONICS*, p 66, Feb. 1950).

The instructor checks every aspect of flight from engine starting to landing, with a system of colored lights indicating the success or failure of pilot reaction. He can at any point throw in problems such as fuel-tank puncture, lightning flashes (with accompanying static), inoperative wing flaps or turbulence. If the pilot becomes too hopelessly confused, the instructor can press the "angelic switch" (pilot failure override) and thus clear the board entirely of all troubles which might possibly arise in flight.

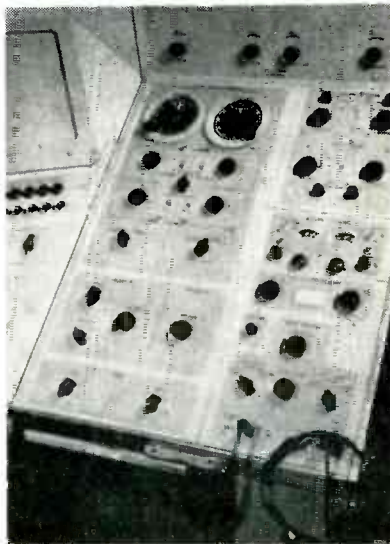

Voice communication and navigational facilities are simulated on the control board at the instructor's right. Fuel tank controls are above

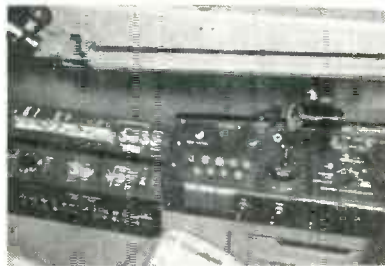

The right side of the pilot's cockpit contains controls for various electrical functions as well as vhf communication and navigation equipment

The trainer is essentially electronic, even to the solution of aerodynamic equations upon which the flight is based. Twenty-four computers comprising servo systems and amplifiers present to the pilot even the different feeling of controls with varying airspeed.

## IRE Convention 1950

CREDITED as the world's largest international engineering body, The Institute of Radio Engineers held its thirty-ninth annual conference in New York at the Hotel Commodore and Grand Central Palace March 6-9, 1950.

During the four-day engineering convention and show, 18,100 members and guests attended from all parts of the United States and some thirty other countries. A total of 169 papers was presented at thirty-six special technical sessions on topics ranging from theory to the finished products in radio broadcasting, television, computing machines, sound recording, circuit theory; uhf transmitter and receiver design and operation.

The accompanying radio show in Grand Central Palace consisted of 253 separate exhibits on three floors. The exhibits included complete radio and television stations in full operation—from electronic pickup to monitoring studio kinescope to subminiature components.

The convention opened March 6 in the Commodore's grand ballroom when the meeting was addressed by Dr. Ralph Bown of the Bell Telephone Laboratories, a past-president of IRE.

On Tuesday, Raymond F. Guy, new IRE president, was the guest of honor at a luncheon. The roster of speakers included Major-Gen. F. L. Ankenbrandt, director of communications, Department of the Air Force, and Sir Robert Watson-Watt of England, the new IRE vice-president. Stuart Bailey, the outgoing IRE president, was toastmaster.

The annual dinner was held at the hotel on Wednesday with H. B. Richmond, chairman of the board of the General Radio Co., Cambridge, Mass., as speaker, and D. G. Fink, editor of *ELECTRONICS*, as toastmaster. The Institute's annual awards for merit in the radio-electric





## ANNOUNCING Kodagraph Autopositive Film

**1. It gives you faster printing intermediates.** Now you can speed up quantity print production... save time and money... with new Kodagraph Autopositive Film! What's more, you, or your local blueprinter, can expose this amazing reproduction material in high-intensity blueprint or direct-process machines... or in a vacuum frame; develop it in standard photographic solutions. You get positive intermediates directly... and the job can be done quickly, economically... under ordinary light.



**2. It holds detail—amazingly.** Kodagraph Autopositive Film combines a high-contrast photographic emulsion and famous Kodak safety film base. It catches the finest line—keeps close lines from “filling in.” Think what an aid this new intermediate material will be in producing print-making “masters” from difficult originals... how it can save you many thousands of dollars in redrafting costs—while assuring final prints of highest quality!

## ... and 4 new advantages in print production for you

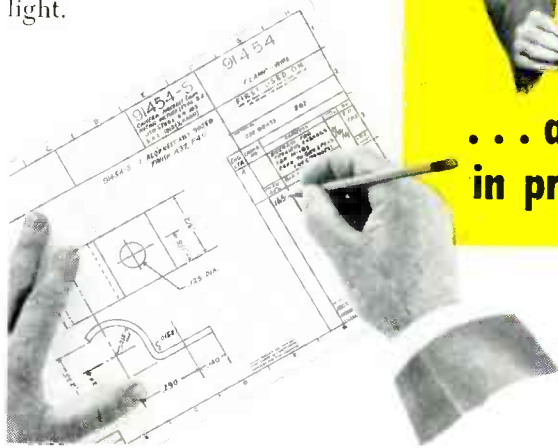

**3. It simplifies revision, reference.** Both sides of Kodagraph Autopositive Film are matte-surfaced... can be written on with pencil or pen. And since the base is highly translucent, details can be read from either side without use of an illuminator.



**4. It even reproduces illustrations and text on opaque stock—**giving you sharp, fast-printing “masters” which will produce sparkling direct-process prints. An economical short cut you'll appreciate in preparing data sheets, instruction manuals, and parts lists.

**Mail coupon today** for this free illustrated booklet giving all the facts on Kodagraph Autopositive Film—the latest addition to the famous Kodagraph line of reproduction materials.



**EASTMAN KODAK COMPANY  
INDUSTRIAL PHOTOGRAPHIC DIVISION  
ROCHESTER 4, N. Y.**

Gentlemen: Please send a copy of your folder on Kodagraph Autopositive Film.

Name \_\_\_\_\_ Position \_\_\_\_\_  
(please print)

Company \_\_\_\_\_ Street \_\_\_\_\_

City \_\_\_\_\_ State \_\_\_\_\_

tronic field were presented at the dinner. The awards include the 1950 Medal of Honor to Prof. F. E. Terman, dean of the school of engineering of Stanford University; the Browder J. Thompson Memorial Prize to J. F. Hull and A. W. Randalis of the U. S. Army Signal Corps civilian staff; the Editor's Award to E. J. Barlow, of the Sperry Gyroscope Co. research laboratories; the Morris Liebmann Memorial Prize to O. H. Schade, research engineer of the RCA Victor Division, and the Harry Diamond Memorial Award to A. V. Haeff, consultant with the Naval Research Laboratory, Washington, D. C.

Thirty fellowship awards of the IRE were presented at the annual dinner. Simon Ramo responded for the group.

### New Radio Propagation Laboratory

APPROVAL has been given for the development of a new 210-acre site at Boulder, Colorado, for a National Bureau of Standards radio propagation laboratory. Actual construction work on the \$4,500,000 project will begin during the summer of 1951. When the laboratory is completed it will employ a research staff of about 300 people, most of whom will be transferred from the present staff in Washington.

The radio division of the Bureau is the central Federal group for the coordination of research on the propagation of radio waves. It is also responsible for development and maintenance of the national primary standards of electric quantities at frequencies above 10 kc. Comprehensive basic and applied research programs are administered by the radio division in radio physics and the associated geophysical phenomena of the atmosphere. Extensive laboratory investigations are being conducted on the properties of matter at radio and microwave frequencies, as well as on ways of making more precise measurements in the r-f region. In addition to its research function, the laboratory renders many advisory and consulting services to other agencies of the government.

Selection of Boulder, Colorado, as

### MEETINGS

<p>APRIL 5-7: Twelfth Annual Midwest Power Conference, Sherman Hotel, Chicago, Ill.</p> <p>APRIL 12-15: Fourth Annual NAB Engineering Conference, Stevens Hotel, Chicago, Ill.</p> <p>APRIL 19-22: Annual Meeting of the Electrochemical Society, Hotel Statler, Cleveland, Ohio.</p> <p>MAY 3-5: 1950 Dayton IRE Technical Conference, Dayton Biltmore Hotel, Dayton, Ohio.</p> <p>MAY 9-11: Conference on Improved Quality Electronic Components, 1317 F Street N W, Washington, D. C.</p> <p>MAY 12-13: Fourth annual meeting of the Armed Forces Communications Association, Hotel Commodore, N. Y., and Fort Monmouth, N. J.</p> <p>MAY 22-25: Parts Distributors Show, Hotel Stevens, Chicago.</p> <p>JUNE 12-16: AIEE Summer and Pacific General Meeting,</p>	<p>Huntington Hotel, Pasadena, Calif.</p> <p>JUNE 26-30: Annual Meeting and 9th Exhibit of Testing Apparatus and Related Equipment, Hotel Chalfonte-Haddon Hall, Atlantic City, N. J.</p> <p>AUG. 23-26: AIEE Pacific General Meeting, Fairmont Hotel, San Francisco, Calif.</p> <p>AUG. 28-31: APCO National Conference, Hotel Hollenden, Cleveland, Ohio.</p> <p>SEPT. 13-15: Sixth Annual Pacific Electronic Exhibit, Municipal Auditorium Long Beach, Calif.</p> <p>SEPT. 18-22: Fifth National Instrument Conference and Exhibit, Memorial Auditorium, Buffalo, N. Y.</p> <p>SEPT. 25-27: National Electronics Conference, Edgewater Beach Hotel, Chicago, Ill.</p> <p>OCT. 17-21: AIEE Midwest General Meeting, Netherland Plaza Hotel, Cincinnati, Ohio.</p>
--	---

the site for the new laboratory was based on the following reasons: (1) It is uncongested by electrical and radio facilities; (2) it is near enough to a large city for equipment and service needs; (3) technical factors call for moderate climate and diversity of terrain; (4) it is near a major university and also close to a major center of air and rail traffic.

### National Tele System Committee Formed

TO ATTAIN industry-wide agreement on technical developments needed for the expansion of television to all sections of the country and to establish basic standards which will bring color television to reality, the RMA has created the National Television System Committee. (Plans for formation of the unit were announced in *ELECTRONICS*, February 1950, p 130).

Chairman of the group is W.R.G. Baker, vice-president of GE and director of the RMA engineering department. Vice-chairmen are Donald G. Fink, editor of *ELECTRONICS*, and David B. Smith, vice-president

of Philco Corp. Leading authorities from qualified technical societies, from broadcasting companies, and from member and non-member firms in the manufacturing industry are invited to participate.

### Communications Policy Board

PRESIDENT TRUMAN recently named a temporary Communications Policy Board, consisting of five members, to study and to make recommendations to him on the policies and practices which should be followed by the government in this field in order best to meet the broad requirements of the public interest. Chairman of the Board is Irvin L. Stewart of the U. of West Virginia. Other members are Lee A. DuBridge of California Institute of Technology, David H. O'Brien of Hackettstown, N. J., William L. Everitt of the U. of Illinois, and James R. Killian of MIT.

The Board's function is to study the present and potential use of radio and wire communications

(Continued on page 252)



PUT BETTER PICTURES ON YOUR TV SCREENS...

BY PUTTING

**SYLVANIA GERMANIUM DIODES**

IN YOUR SETS!

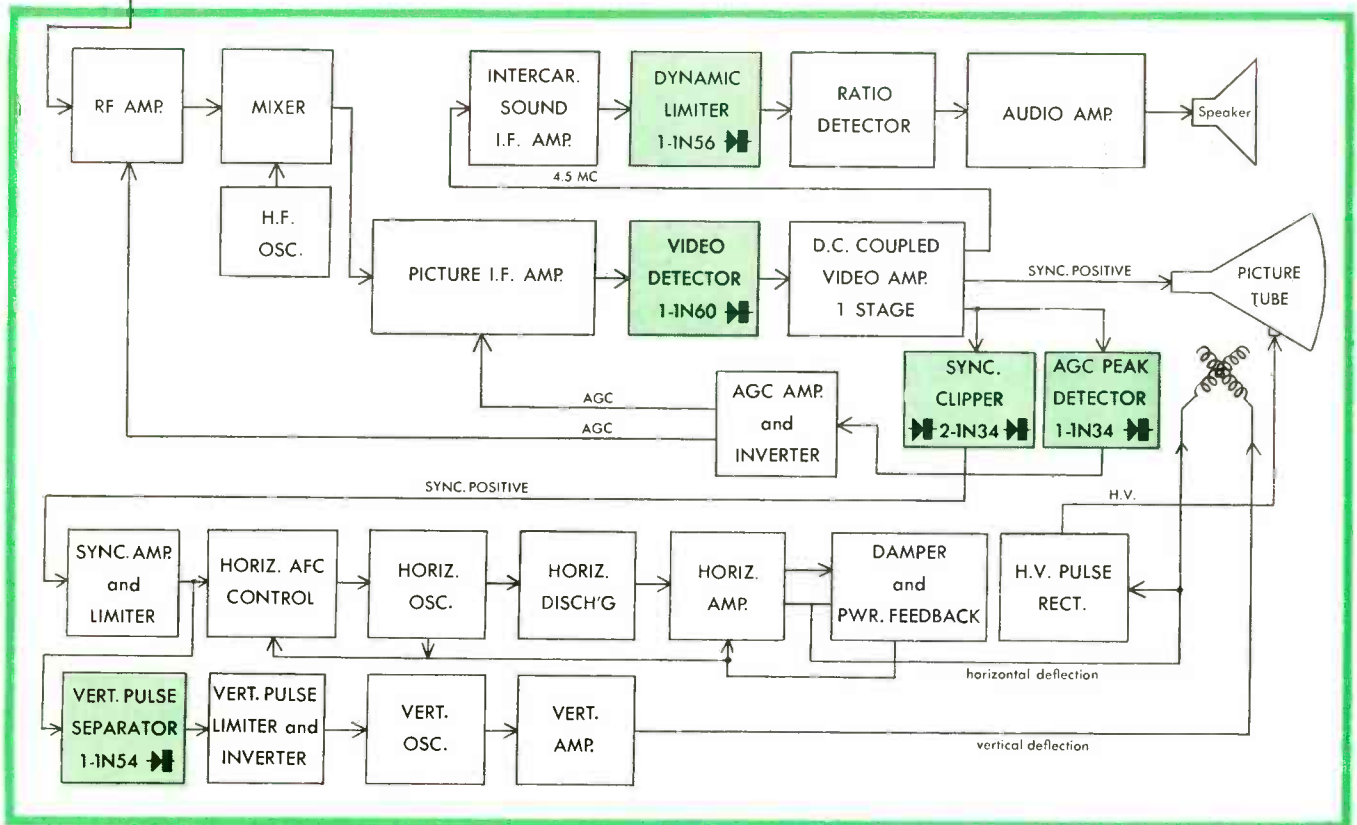

Here are 5 television receiver applications especially suited to utilize to the full the inherent advantages of these unique circuit components

Designers of television receivers can substantially improve set performance through the use of Sylvania Germanium Diodes. Outstanding features of these elements in TV set design are freedom from hum, high efficiency,

low capacity, no contact potential and exceptional linearity. Of course, in TV receivers as in all other applications, Sylvania's Germanium Diodes offer the advantages of small size and ease of mounting.

Find out just *how* and *why* Sylvania Germanium Diodes make television receivers better. Mail coupon for Electronic Engineering News Letter #8, which gives detailed circuit information on the 5 applications shown in the block diagram above.

**SYLVANIA  
ELECTRIC**

Electronics Division, 500 Fifth Avenue, New York 18, N. Y.

ELECTRONIC DEVICES; RADIO TUBES; CATHODE RAY TUBES;  
PHOTOLAMPS; FLUORESCENT LAMPS, FIXTURES,  
WIRING DEVICES, SIGN TUBING; LIGHT BULBS



Sylvania Electric Products Inc.  
Advertising Dept., Room E-1004  
Emporium, Pa.

Gentlemen:  
Please send me your Engineering News Letter #8,  
"Applications of Sylvania Germanium Diodes in Tele-  
vision Receivers."

Name \_\_\_\_\_

Company \_\_\_\_\_

Address \_\_\_\_\_

City \_\_\_\_\_ State \_\_\_\_\_

# NEW BOOKS

Practical Spectroscopy.....	132
Electronic Time Measurements.....	132
Saturating Core Devices.....	257
Books Received for Review.....	257

## Practical Spectroscopy

BY G. R. HARRISON, R. C. LORD, AND J. R. LOOFBROUROW, *all of the Spectroscopy Laboratory, MIT. Prentice-Hall, Inc., New York, 1948, 605 pages, \$6.65.*

WHILE the radio engineer has been pushing his techniques to shorter wavelengths, the spectroscopist has been pushing his methods to longer ones. These two technologies are meeting in the service of science in the far infrared region where wavelengths are in the order of a millimeter.

This comprehensive volume, writ-

ten by a physicist, a chemist and a biophysicist, presents the wide variety of techniques used by spectroscopists for both scientific and industrial work. The twenty chapters into which the book is divided provide readers with an introduction to the general techniques of the subject, a review of instruments, their adjustment and care, light sources, photographic techniques, the atomic and molecular origins of spectra, qualitative and quantitative spectrographic analysis, and the special methods necessary for the infrared and ultraviolet regions.

The book should be interesting to readers of ELECTRONICS because it deals both with methods that they may wish to employ in the microwave region and with equipment for which they can provide special features and automatic instrumentation.—F. H. ROCKETT, JR., *Airborne Instruments Laboratory, Inc., Mineola, N. Y.*

## Electronic Time Measurements

*Volume 20 of the MIT Radiation Laboratory Series. EDITED BY B. CHANCE, R. I. HUGHES, E. F. MACNICHOL, AND F. C. WILLIAMS. McGraw-Hill Book Co., New York, 1949, 538 pages, \$7.00.*

THIS VOLUME, as in all of the Radiation Laboratory Series, shows the results of the great effort put forth by a group of extremely competent men. In combination with Volume 19, "Waveforms," it will be an invaluable tool in the hands of the circuit design engineer. As its name

(Continued on p 256)

# BACKTALK

This Department is Operated as an Open Forum Where Readers may Discuss Problems of the Electronics Industry or Comment Upon Articles which ELECTRONICS has published

The article, in any event, was interesting and thought-provoking.

WILLIAM C. SCHUMACHER  
*Brooklyn, New York*

## VHF from Incandescent Lamps

DEAR SIRs:

IN YOUR December 1949 "Tubes at Work" I was interested to see an article called "TV Interference from Incandescent Lamps."

My earliest encounter with vhf radiation of this type took place about twenty years ago when I was amateur 9BBH operating a mobile 5 meter station around the streets of Cedar Rapids, Iowa. It was noticed one day that a high-pitched tone was received at a certain street intersection. This tone came in on the superregenerative receiver only occasionally and was finally traced to the operation of street cars. Finally it was determined that a trolley-operated light signal (used to indicate to another street car several blocks away that the block was occupied) was the cause. Closer examination showed that the

(Continued on p 258)

## Please Pass the Salary

DEAR SIRs:

THE ITEM on salaries in January Crosstalk contained interesting and (very likely) accurate information with respect to the earnings of various types of engineers, but it contained also an implication of the type that was long ago responsible for two old saws. "Figures don't lie, but liars figure" and "There are three degrees of prevaricators: liars, damn liars, and statisticians." (Pardon the language; and please do not infer that the editorial writer is aptly encompassed by either of the quotations.)

The passage at the end of the second paragraph of the article almost comes right out and says that

electrical engineers can expect, after thirty-seven years, to experience declining earnings, else why the remark that they "are due for a rude shock"? It should be pointed out that perhaps the men who had enjoyed above-average earnings would have retired by the time they worked thirty-seven years, leaving the field to those whose earnings had been below average. It might even be found that the "per-individual" earnings in all brackets increased indefinitely up to the point at which each individual left his professional duties by retiring or otherwise. This would be in no way inconsistent with the statistics quoted in your article, and I for one hope that this is the actual situation.





## The Redskin of course...

### SANGAMO'S NEW MOLDED PAPER TUBULAR CAN HELP SOLVE YOUR PRODUCTION LINE PROBLEMS!

The Sangamo Redskin has the "How" it takes to tie into production lines. The strong, tough plastic casing stands rough handling and the especially designed, flexible leads are troublefree . . . they resist breakage and they can't pull out. It is used extensively by television manufacturers because it gives dependable *long life* operation at 85° C. The thermo-setting plastic case is molded under low pressure—assuring elements undamaged in fabrication, longer life, greater dependability, and the absence of "hot spots."

A trial of these *better* molded tubulars will convince you. See your Jobber, or write for Catalog No. 800, which gives full information on the Redskin and the rest of the Sangamo Tribe.

### NEVER FLINCHES IN THE PINCHES!



#### WATER TEST

Far surpasses any existing specification requirement.



#### HEAT TEST

Excellent operation under high temperature conditions.



#### PULL TEST

Leads resist breaking or pulling out. Takes rough handling.



#### LIFE TEST

Long life even under most severe operating conditions.



## SANGAMO ELECTRIC COMPANY SPRINGFIELD, ILLINOIS

In Canada: Sangamo Electric Company Limited, Leaside, Ont.





**The Engineer says:  
All I need to know in  
specifying coaxial cables  
to military standards is  
tabulated on this Amphenol  
Wall Chart . . .**

**This colorful chart (or  
ring-binder size tabulation)  
available on request. Write  
Department 16.**



**AMERICAN PHENOLIC CORPORATION**  
1830 SO. 54TH AVENUE • CHICAGO 50, ILLINOIS

**TUBES AT WORK**  
(continued from p 118)

of a fractional-horsepower electric motor.

Because of space limitations, an ordinary generator-type tachometer could not be used. The necessity of knowing the angular velocity of this varying motor at any instant made it inconvenient to use a revolution counter. The additional criterion of physically small, low-friction contacts on the motor shaft had to be considered also. The problem was that of devising an accurate tachometer which could be operated by small electrical contacts on the motor shaft and at the same time present a negligible load to the motor. Electrical means had to be employed because the motor in question was located inside a high-pressure steel bomb.

The solution was found in a square-wave generator-frequency meter circuit. The essential components of the instrument are shown schematically in Fig. 1. A d-c current is chopped into square waves by means of the rotor *A* which is mounted on the motor shaft and which contains a nonconductor *E* acting as a current interrupter. This square wave is then fed to capacitor *B* which becomes charged. During the period when the current is interrupted, the capacitor discharges through resistance *C* and causes ammeter *D* to indicate a current flow. The relation of the magnitude of the current indicated by the meter to the rate of interruption of the current in resistance *C* is a function of the capacitance and the potential applied to resistance *C*.

Several changes were necessary in this simple circuit in order that reproducible and consistent results

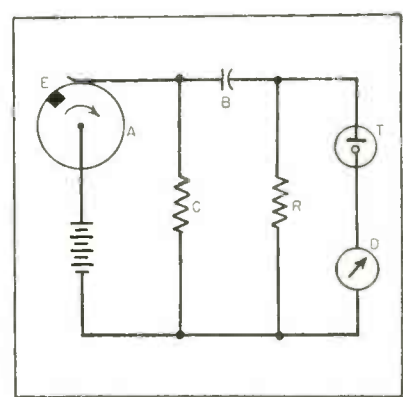

FIG. 1—Schematic circuit of tachometer



# Announcing

# 6

# MORE MINIATURE COMPONENTS

ahead of demand  
for smaller, lighter,  
more accurate instrumentation units

## ARMA 03 SYNCHROS

Here are the new Synchro Units Arma manufactures specifically to meet the demand for compact servo-mechanisms in modern instrumentation.

They are designated as Arma's 03 Group and require 24 volt 400 cycle excitation.

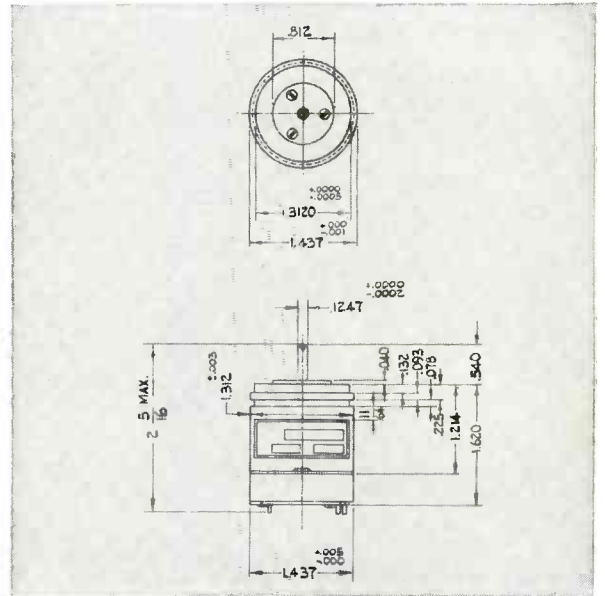

Type	Dwg. No.	Freq.	Input	Voltage Output	Amp.	Watts	Static Accuracy	Rotor Inertia (oz. in. <sup>2</sup> )	Static Friction (oz. in.)	Weight (lbs.)
03G400	715646	400	24	24	0.065	0.40	±12'	0.05	0.5	¼
03DG400	715674	400	24	24	0.025	0.20	±12'	0.05	0.5	¼
03CT400	715649	400	24	24	0.025	0.20	±15'	0.05	0.1	¼
03GG400	787042	400	24	24	0.065	0.40	±30'	0.05	0.5	¼
03DDG400	787046	400	24	24	0.025	0.20	±30'	0.05	0.5	¼
03CCT400	787044	400	24	24	0.025	0.20	±30'	0.05	0.1	¼

### TYPICAL SPECIFICATIONS

The units of this group differ little except in electrical characteristics. They look alike and are of the same physical dimensions.

SYNCHRO CATALOG JUST PRINTED  
GIVES COMPLETE DETAILS—ASK FOR A COPY

## ARMA CORPORATION

254 36th STREET, BROOKLYN 32, N. Y.

SUBSIDIARY OF AMERICAN BOSCH CORPORATION



ARMA  
PRODUCTS  
RELEASED  
FOR  
PRIVATE  
INDUSTRY

ARMA ELECTRICAL RESOLVERS\* ARMA SYNCHROS ARMA INDUCTION MOTORS ARMA INDUCTION GENERATORS ARMA MECHANICAL DIFFERENTIALS ARMA ALTERNATING VOLTAGE COMPARATOR COMPUTING MECHANISMS INDUSTRIAL CONTROLS STABILIZATION DEVICES NAVIGATIONAL EQUIPMENT LIMITRON AUTOMATIC INSPECTION SYSTEM

\* Licensed for use under Arma patents Nos. 2,465,624 and 2,467,646. License information available.

QUALITY **ARMA** PRECISION  
INSTRUMENT

YOU CAN DO IT BETTER WITH **FORMICA**

**New glass-silicon grades** of laminated plastic offer the maximum of heat-, arc- and acid-resistance *plus* low dielectric losses in power and radio frequencies. These and other Formica grades—in sheet, tube, rod and special molded forms—are used successfully for thousands of electrical applications. You can mill, drill, turn, punch, thread, stamp or postform it. Send today for your free catalog... prove to yourself that "you can do it better with Formica"!

**FORMICA**,  
4640 Spring Grove Ave.  
CINCINNATI 32, O.

Productive  
**FORMICA**  
at Work in Industry

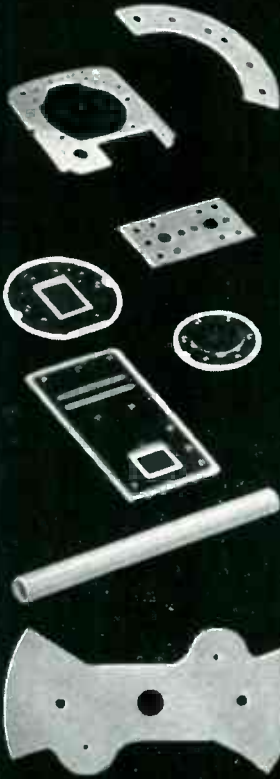

**FORMICA**  
makes a  
grade  
that "Makes  
The Grade"

# American Beauty

## ELECTRIC SOLDERING IRONS

are sturdily built for the hard usage of industrial service. Have plug type tips and are constructed on the unit system with each vital part, such as heating element, easily removable and replaceable. In 5 sizes, from 50 watts to 550 watts.

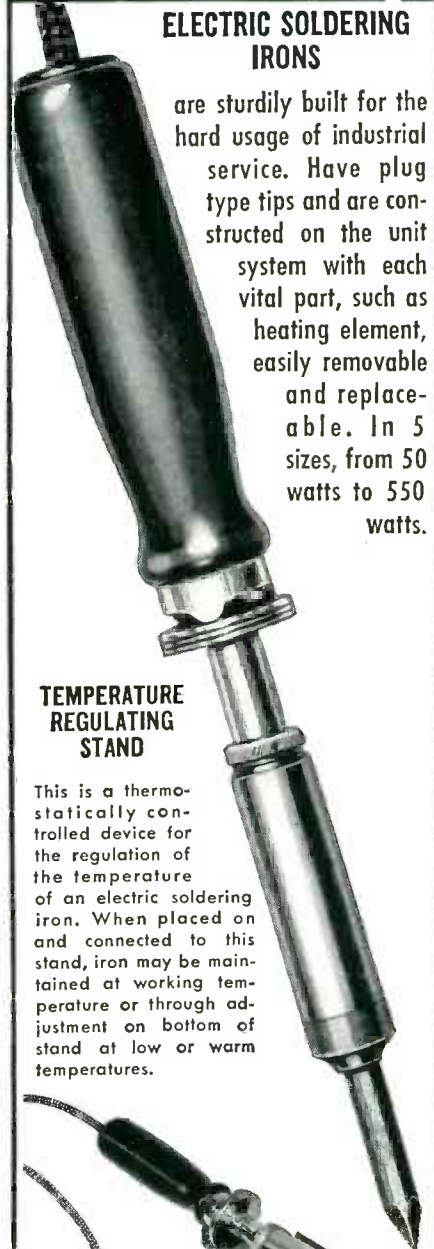

### TEMPERATURE REGULATING STAND

This is a thermostatically controlled device for the regulation of the temperature of an electric soldering iron. When placed on and connected to this stand, iron may be maintained at working temperature or through adjustment on bottom of stand at low or warm temperatures.

For descriptive literature write

110-1

**AMERICAN ELECTRICAL  
HEATER COMPANY**  
DETROIT 2, MICH., U. S. A.

# KENYON *Fits Your* Production To A "T"

**KENYON "T's"**—high quality, uniform transformers, are your best bet for development, production and experimental work. For over 20 years, the KENYON "K" has been a sign of skillful engineering, progressive design and sound construction.

Now—reduce inventory problems, improve deliveries, maintain your quality—specify KENYON "T's," the finest transformer line for all high quality equipment applications.

**New Catalog Edition! Write Today!**

**KENYON** new modified edition tells the complete story about specific ratings on all transformers. Our standard line saves you time and expense.

Send for your copy of our latest catalog edition now!



**KENYON** TRANSFORMER CO., Inc.  
840 BARRY STREET · NEW YORK 59, N. Y.



**To TV manufacturers!**

# Here's Another Milestone in RECTIFIER PROGRESS by *Federal*

**Who Pioneered the  
Selenium Rectifier  
for TV Design**



**450 MA.\***  
Type 1021  
For large consoles

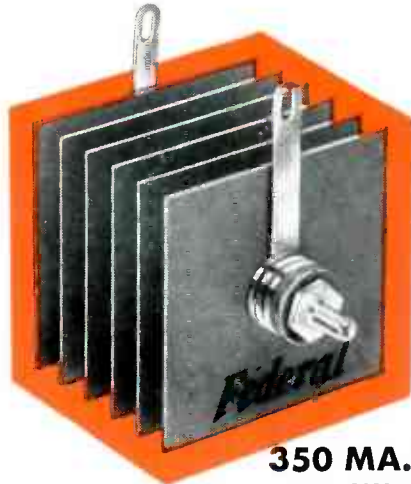

**350 MA.\***  
Type 1023  
For large table models  
and small consoles



**250 MA.\***  
Type 1010  
For small table models

## **FEDERAL** *Announces*

its "Blocks of Power"... Three New Selenium Rectifiers in Ratings to Cover the Full Range of TV Power Requirements with these New Features —

**1 ALL ALUMINUM**  
Plates, washers, mounting studs—all aluminum! Same coefficient of expansion under all operating conditions.

**2 SIMPLIFIED MOUNTING**  
No need to stock a variety of mounting hardware. Single-end stud with simple nut and washer permits mounting anywhere in any position.

**3 RUGGED CONSTRUCTION**  
Improved mechanical design, using a one-piece mounting stud, provides a sturdy mechanical assembly that will withstand stress and shock.

**4 COOLER OPERATION**  
Resulting from improved design and production techniques—and even greater quality control of materials.

Federal opened the way to smaller, lighter weight TV receivers. Now Federal goes further... provides still further weight saving for receivers of *all* sizes... meets all major TV power requirements... with new stacks to operate with the higher rated capacitors used in latest TV design. Write today for full information. Address Dept. F-713. \*Ratings shown are typical

*America's Oldest and Largest Manufacturer of Selenium Rectifiers*

## *Federal Telephone and Radio Corporation*



FEDERAL TELECOMMUNICATION LABORATORIES, Nutley, N. J. ... a unit of I T & T's world-wide research and engineering organization.

SELENIUM and INTELIN DIVISION, 100 Kingsland Road, Clifton, New Jersey

In Canada: Federal Electric Manufacturing Company, Ltd., Montreal, P. Q.  
Export Distributors: International Standard Electric Corp., 67 Broad St., N.Y.



save space  
reduce weight  
**USE TRANSICOIL**  
PLATE TO PLATE CONTROL MOTORS  
PRECISION GEAR TRAINS

NO OUTPUT  
TRANSFORMER  
NEEDED

60 CYCLE  
OR 400 CYCLE

There Is A Transicoil Unit Designed  
To Meet the Requirements Of Your  
Particular Application

Complete Technical Data  
Available Upon Request

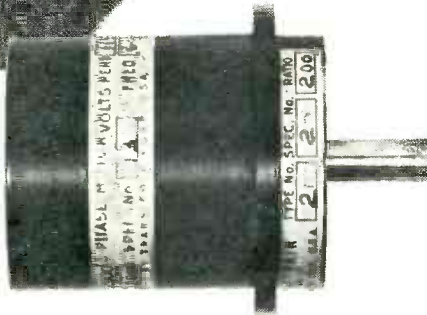

# TRANSICOIL CORPORATION

114 Worth St.,  
New York 13, N. Y.

**SAVE TIME  
SAVE MONEY!**

**BUILD PRECISION INSTRUMENTS  
WITH EICO KITS**

Build it yourself and save the assembly labor cost. The schematic and pictorial diagrams enclosed with each EICO Kit are easy to follow, it's no trick at all to complete the job in one evening!

Ideally suited for TV: EICO VTVM goes to 30,000 volts and over 200 Mc with our accessory probes—EICO Sweep Generator has TV channels marked on panel and crystal marker—new EICO 'scope has high sensitivity and Push-pull.

West Coast prices 5% higher.  
Write NOW for our new catalog "E"

**ELECTRONIC INSTRUMENT CO., INC.**  
276 Newport Street, Brooklyn 12, N. Y.

**320K SIGNAL GENERATOR KIT \$19.95**  
Wired \$29.95

**221K HIGH PRECISION VACUUM TUBE VOLTMETER KIT \$23.95**  
Wired \$49.95

**145K MULTI-SIGNAL TRACER KIT \$18.95**  
Wired \$28.95

**315 DELUXE SIGNAL GENERATOR \$52.95**  
Wired only

**360K SWEEP SIGNAL GEN'R'T'R KIT \$29.95**  
Wired \$39.95

**425K 5" PUSH-PULL 'SCOPE KIT \$39.95**  
Wired \$69.95

**511K POCKET VOLT-OHM-MILIAMMETER KIT \$14.95**  
Wired \$17.95

**HI-VOLTAGE PROBE**  
Wired only \$6.95

**HI-FREQ PROBE KIT \$3.75**  
Wired \$7.50

**5 Mc. Crystal \$3.95**

**EASY-TO-FOLLOW SCHEMATIC & PICTORIAL DIAGRAMS WITH EVERY EICO INSTRUMENT KIT.**

**SPRING IS SURE HERE!**  
IN  
**GARRETT**  
**SPRING WASHERS**

**CONTROLLED TENSION**

Garrett Spring Washers are made to hold right... stay tight. Exclusive Controlled Tension built into each washer to provide exact holding power for longer time.

**PRECISION SIZES**

Each washer is made to meet exacting size specifications—l. D., O. D., height and material thickness is scientifically controlled to Nth degree accuracy.

**RIGIDLY INSPECTED**

Garrett's laboratories and quality control tests assure highest quality in finished products. Size, shape, and finish are all carefully checked to meet rigid specifications.

**100 VARIETIES**

Bellville, bevel, wave and many other types are all included in the more than 100 varieties of types and sizes available in Garrett's standard line. We welcome your request. Send in your specifications. We can probably save you plenty in die costs. Write for our booklet. Let us prove it.

GARRETT'S MANUFACTURE A COMPLETE LINE OF LOCK WASHERS... FLAT WASHERS... STAMPINGS... HOSE CLAMPS... SPRINGS

**GEORGE K. GARRETT CO., Inc.**  
PHILADELPHIA 34, PA.





# NOW

**Potter & Brumfield**

**GIVES YOU**

## WORLD'S SMALLEST TELEPHONE RELAY

**... HERMETICALLY SEALED IN STEEL CASE**

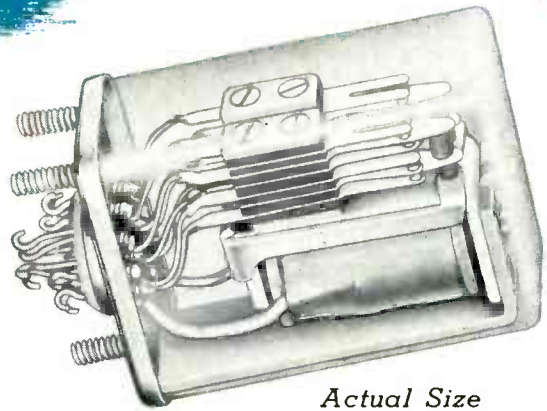

*Actual Size*

$1 \times 1\frac{1}{16} \times 2\frac{5}{32}$

**NEW MT ASSEMBLY saves inches . . . permits more design freedom in your product!**

● New Potter & Brumfield MT (Miniature Telephone) hermetically sealed assembly saves more than  $\frac{1}{3}$  of chassis mounting space. Available with windings from a fraction of an ohm to 22,000 ohms for operation up to 230 volts, AC or DC.

Note features of the exclusive new P & B development listed on this page. Write for full information on your particular needs! Progressive P & B engineering service is available to solve every relay problem. New catalog free on request.

### THE CLOSURE

Potter & Brumfield "M" type enclosure (illustrated) was especially developed for the MT relay . . . will accommodate the MT with maximum contact stack and can be fitted with all headers except standard octal plug. . . . All P & B enclosures for hermetically sealed relays are deep drawn steel, cadmium plated and painted as specified. Headers are glass insulated with high thermal shock resistance and minimum leakage resistance of 10,000 megohms at 50% humidity. . . . Up to 14 hot-tipped solder terminals and plug-in connectors for 9 pin standard miniature or 14 pin special\*. . . . P & B "K" type enclosure  $1\frac{5}{8} \times 1\frac{13}{32}$  x  $2\frac{1}{16}$ "—(not illustrated), will take any "MT" or P & B "KR" series with any header including standard octal plug. The "K" can be provided with three  $\frac{5}{32}$ " mounting studs centered on  $\frac{15}{16} \times \frac{3}{16}$ " dimensions. . . . Hermetically sealed relays are desiccated at high temperature and sealed in one atmosphere of nitrogen, which eliminates oxidation and reduces contact arcing. Leakage test by immersion in pure water at 200°F.

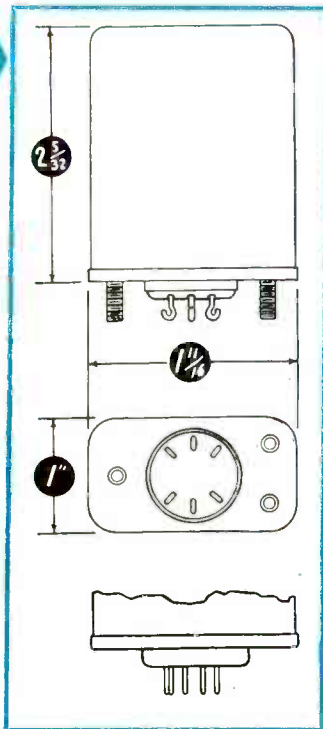

### THE RELAY (Actual Size)

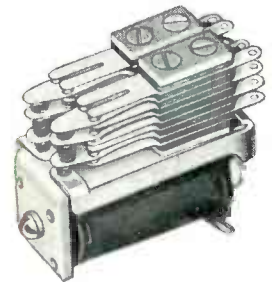

Dimensions of the open relay are only  $1\frac{1}{16}$ " wide by  $1\frac{1}{2}$ " long and  $1\frac{3}{8}$ " high . . . with 12 springs in dual stack. . . . Minimum operating power .050 watts per pole, permitting sensitivity of  $1/5$  Ma. in a single

pole relay with 22,000 ohm winding. Maximum coil power 4 watts for the unenclosed unit. . . . Mounting of the open relay is by 4 holes in end of frame on  $\frac{3}{8}$ " centers tapped 3/48 or 4/40 if specified. . . . Dual stack with contacts of any arrangement up to 16 springs (8 per stack) with a limit of six movable poles. . . . Contacts .094" spherical No. 18 gauge, Code 3 pure palladium welded to nickel-silver springs and rated at 2 amps, or on special applications higher contact ratings and lower contact resistance may be provided with silver rivet contacts on phosphor bronze springs. Tin dipped solder terminals. . . . Stack insulation, laminated paper-base phenolic or molded class G2 melamine per JAN-P-14 as specified. Anti-fungus treatment of insulation and coil when ordered. . . . Core and frame of high permeability steel, ground to micrometer dimensions after assembly to insure maximum performance. . . . Open relay coils thoroughly baked and varnish impregnated against moisture and mechanical damage. Hermetically sealed relay coils protectively coated with cellulose acetate unless otherwise

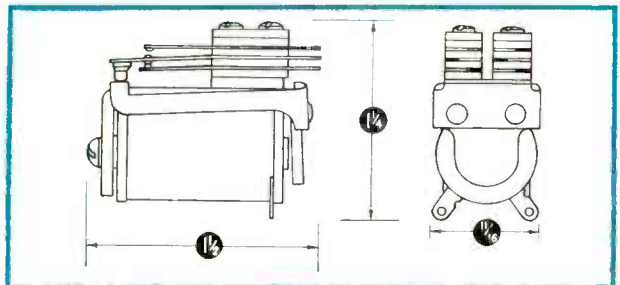

specified. . . . Armature hinge, heat treated beryllium copper tested and proven to exceed 100-million operations. Eliminates wear and loose hinge. . . . Vibration and shock resistance to better than 10G with minimum of 1.5 watts in coil. . . .

STANDARD P & B RELAYS ARE AVAILABLE AT YOUR LOCAL ELECTRONIC PARTS DISTRIBUTOR

# Potter & Brumfield

213 N. MAIN STREET  
PRINCETON, INDIANA

EXPORT: 2020 ENGINEERING BLDG. CHICAGO 6, ILLINOIS, U. S. A.

\*We can supply sockets for 14 pin special.

# An EASY and ACCURATE Way to Measure Audio Frequency Voltages



**Ballantine Model 300**  
**SENSITIVE**  
**ELECTRONIC**  
**VOLTMETER**  
 Featuring a Logarithmic  
 Voltage Scale and  
 Uniform Decibel Scale

- Designed for the measurement of AC Voltages from .001 Volt to 100 Volts over a frequency range of 10 to 150,000 cycles. ● Accuracy of readings is  $\pm 2\%$  at any point on the scale. ● Very stable calibration—unaffected by changes in line voltage, tubes or circuit constants.
- Range switching in decade steps—easy to use—only ONE scale to read. ● Output jack and output control provided so that Voltmeter can be used as a high-gain (70 DB) high-fidelity amplifier. ● Accessories available to extend readings up to 10,000 Volts and down to 10 microvolts. ● Precision Shunt Resistors convert Model 300 Voltmeter to very sensitive direct-reading milliammeter. ● Write for complete data.

PRICE . . . . . \$200.00

**BALLANTINE**  
**LABORATORIES, INC.**  
 BOONTON N. J. · U.S.A.

In addition to the Model 300 Voltmeter, Ballantine Laboratories also manufacture Battery Operated Electronic Voltmeters, R. F. Electronic Voltmeters, Peak to Peak Electronic Voltmeters, and the following accessories—Decade Amplifiers, Multipliers, Precision Shunt Resistors, etc.

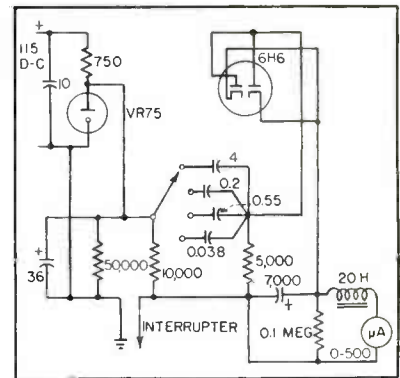

FIG. 2—Charging voltage is obtained from a d-c line

might be obtained. The complete circuit of the tachometer is shown in Fig. 2. Thus additional capacitors were installed in order to smooth the action of the microammeter pointer. More capacitors were installed in addition to a suitable switching arrangement so that several speed ranges could be used. A rectifier tube and choke provide a more pure square wave. A voltage regulator tube was used to advantage in eliminating normal fluctuations of the line current.

The rotor mounted on the motor shaft was fitted with ten equally sized and equally spaced interrupters made of plastic. These were so designed that the conducting segments of the rotor were of the same size as the interrupters, thus providing equal on and off time per revolution. The spring contact on the rotor was made of steel music wire with a silver soldered copper tip which contacted the brass rotor. Placing the spring contact in a peripheral groove cut in the rotor improved the dependability of the operation.

### Calibration

To obtain the proper scale coverage on the microammeter with various motors to be used with this circuit, the bank of capacitors was provided. The relation between these capacitors and the frequency of current interruption is given in Fig. 3. This curve can also be represented by the following equation;  $\log C = 0.8248 - \log S$  where  $C$  = capacitance in microfarads and  $S$  = frequency in cycles per second. Thus if any motor having a rotational frequency within the range given on Fig. 3 were used, the cor-



RESISTS MOISTURE, MECHANICAL RUPTURE . . . HAS HIGH DIELECTRIC STRENGTH . . .

Why leading electrical manufacturers specify **Kodapak Sheet**

MORE than one type of Kodapak Sheet is available. For a particular application, one of the Kodapak technical representatives will be glad to help select the Kodapak Sheet with properties best adapted to the specific use. Write to the Rochester office, giving essential details.



A voltage breakdown test of Kodapak Sheet.

**In condenser construction . . .** Kodapak Sheet offers desirable properties. Its dielectric constant permits units of small dimensions. Impregnants are not necessary. And a relatively low degree of moisture-absorption makes possible the exposure of the finished product to high humidities for extended periods.

**For primary wire insulation . . .** Kodapak Sheet offers dielectric strength—over a wide range of temperatures. It combines strength and toughness with the ability to stretch more than 60% before rupturing; thus it may be flexed, or bent around small radii without harming insulation. And high moisture-resistance minimizes the production of corrosive acids which tend to affect copper under certain conditions.

**In slot-cell construction.** Here, also, Kodapak Sheet is particularly valuable. Various combinations are possible which offer savings both in space and cost. For example, laminated to both sides of (or between) sheets of special insulation paper, it requires less thickness than paper alone; assures more compact, easily handled inserts.

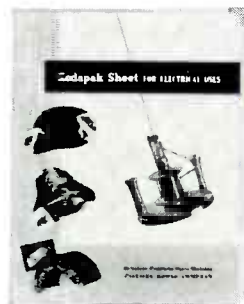
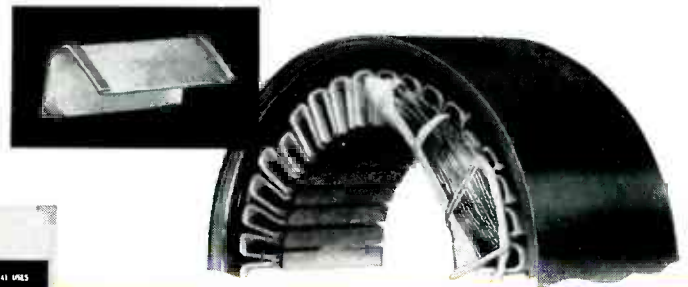

Write for free copy  
of the folder,

*“Kodapak Sheet for Electrical Uses.”*

**Kodapak  
Sheet**

. . . for efficient insulation

“Kodapak” is a trade-mark

Cellulose Products Division, Eastman Kodak Company, Rochester 4, N. Y. Sales offices in New York, Chicago. District sales representatives in Cleveland, Philadelphia, Providence. Pacific Coast distributor: Wilson & Geo. Meyer & Co., San Francisco, Los Angeles, Portland, Seattle. Canadian distributor: Paper Sales, Limited, Toronto, Montreal.

**Kodak**  
TRADE-MARK

# DO YOU KNOW?

— that a **PILOT LIGHT**  
CAN IMPROVE YOUR PRODUCT

... add attraction — safety — service?

Ask

**DIALCO**

- what lamp to use
- how to use it
- what it will do
- what it will cost

**THIS MAY BE THE ONE**  
Designed for low cost NE-51 Neon

- Built-in Resistor • Patented
- U/L Listed • Rugged

Catalogue Number 521308 — 997  
for 110 or 220 volts.

**SAMPLES**  
for design purpose  
**NO CHARGE**

**NEW!** Write for the  
"HANDBOOK OF PILOT LIGHTS."

Write us on your design problems.



**The DIAL LIGHT COMPANY of AMERICA**

*Foremost Manufacturer of Pilot Lights.*

900 BROADWAY, NEW YORK 3, N. Y. TELEPHONE SPRING 7-1300

# ZOPHAR

## Waxes, Compounds and Emulsions

Materials for potting, dipping or impregnating all types of radio components or all kinds of electrical units. • Tropicalized fungus proofing waxes. • Waterproofing finishes for wire jackets. • Rubber finishes. • Inquiries and problems invited by our engineering and development laboratories.



Zophar Mills, Inc. has been known for its dependable service and uniformity of product since 1846.

**ZOPHAR MILLS, Inc.**

ESTABLISHED 1846

117 26th STREET, BROOKLYN 32, N. Y.

## POSITIONS OPEN

For

### SENIOR RESEARCH ENGINEERS

And

### PHYSICISTS

Established Electronic and Control Laboratory in the Los Angeles, California area, offers exceptional opportunities for Senior Engineers and Physicists having outstanding academic background and experience in the fields of

- Microwave Techniques
- Moving Target Indication
- Servomechanisms
- Applied Physics
- Gyroscopic Equipment
- Optical Equipment
- Computers
- Pulse Techniques
- Radar
- Fire Control
- Circuit Analysis
- Autopilot Design
- Applied Mathematics
- Electronic Subminiaturization
- Instrument Design
- Automatic Production Equipment
- Test Equipment
- Electronic Design
- Flight Test Instrumentation

Salaries commensurate with ability, experience and background. Working conditions and opportunities for advancement are excellent. Send information as to age, education, experience and work preference to:

**NORTH AMERICAN AVIATION, INC.**

*Aerophysics Laboratory*

Box No. K3

12214 South Lakewood Blvd.

Downey, California



# This may be the solution to your D. C. AMPLIFICATION problems

## MICROSEN

### D. C. AMPLIFIER

Simple in operation, the Microsen D. C. Amplifier is designed to meet the need for stable and accurate amplification. It is compact to provide easy portability and convenient general use, is moderate in cost. The amplifier has many applications in both laboratory and field work. Three different ranges are furnished in a single model. The Microsen Balance, an electro mechanical feedback amplifier, combines the advantages of high torque to current input ratio with rugged, shock-resistant construction. Available models include Voltage, Current and Potentiometer Type Amplifiers, Direct Current Converters, Direct Current Transformers, and Engineered Designs to meet special requirements.



#### TYPICAL APPLICATIONS OF THE MICROSEN D. C. AMPLIFIER

Field of Measurement	Input Element	Output Instrument	Application	Design Advantages
Thermometry	Thermocouple	Recorder	Combustion Research Gas Turbine Development Thermocouple Inspection Meteorology Distillation Processes	High Speed Response Accuracy Sensitivity Stability
Photometry	Photo Cell	Recorder	Polarimetry Physiology of Blood Fluid Flow & Turbulence Density	Stability Sensitivity Responsive Accuracy
Gas Analysis	Catalytic Filament Thermocouple	Recorder	Detecting Explosive Mixture Efficiency of Filters Mixture Control	Sensitivity Stability Accuracy High Speed Response
Electrical Bridges	Resistors Resistance Elements	Recorder	Resistor Inspection Moisture Detection Conductivity Measurements	Sensitivity Stability Accuracy Fast Response
	Pirani Gauge		Vacuum Gauging	Stability
	Strain Gauge		Transient Stresses	Accuracy
Electronics	Inductance Ionization Thermionic	Recorder	Wave Guide Studies Vacuum Gauging Tube Development	Sensitivity Stability Low Resistance Input
Electrolysis	Electrolytic Cells Current Shunt	Recorder	Production Control Electrolytic Plating Electrolytic Process	Isolated Input Stability Accuracy

In each of the above applications, the Recorder could be replaced with a suitable milliammeter indicator, or the output can be used to actuate automatic control relays or signal devices. Inquiries for modification within the useful scope of the Microsen D. C. Amplifier are invited. If possible, such inquiries should contain complete application specifications.



# MICROSEN



## ELECTRICAL INSTRUMENTS

A PRODUCT OF

### MANNING, MAXWELL & MOORE, INC. STRATFORD, CONNECTICUT

Makers of 'Microsen' Electrical and 'American' Industrial Instruments, 'Hancock' Valves, 'Ashcroft' Gauges, 'Consolidated' Safety and Relief Valves. Builders of 'Shaw-Box' Cranes, 'Budgin' and 'Load Lifter' Hoists and other lifting specialties.

Manning, Maxwell & Moore, Inc.  
250 East Main Street  
Stratford, Conn.

We are interested in your Microsen D. C. Amplifier. Please send the bulletin describing the instrument to the following address:

Name \_\_\_\_\_  
Position \_\_\_\_\_  
Company \_\_\_\_\_  
Street Address \_\_\_\_\_  
City \_\_\_\_\_ State \_\_\_\_\_

# TOROIDS

by

**B&W**

...to your **SPECIFICATIONS**

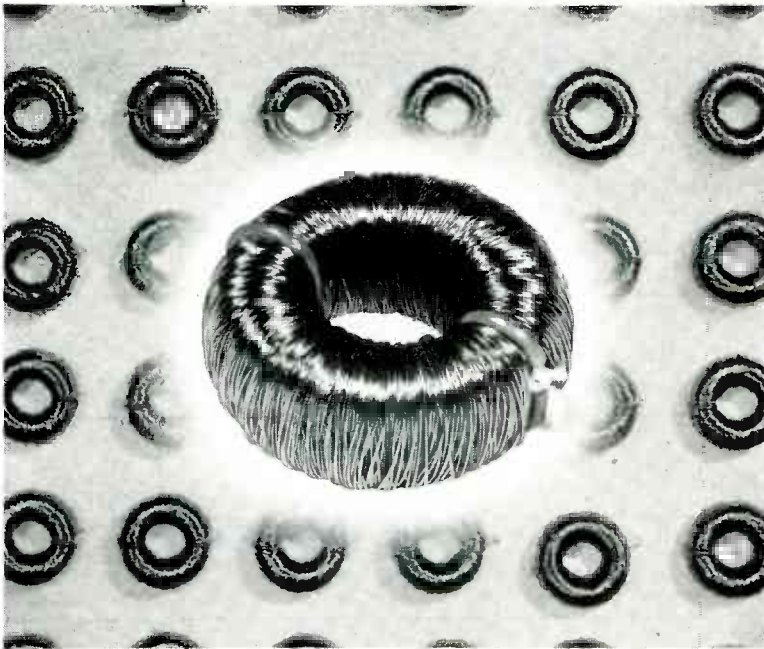

Development of stabilized, high permeability cores of various types and grades, has greatly increased the applications of toroid coils in the low frequency range from 500 cycles to 200 KC. B&W toroids feature high inductance and high Q within a minimum of space and confined electrical field. These features assure the highest performance in many types of filters or networks.

Over fifteen years background in coil design and manufacture, plus the latest toroidal coil winding equipment, provides a combination that makes it possible for B&W to meet your most exacting requirements. B&W Toroidal Coils are available in open types, shielded, potted or hermetically sealed units in addition to complete filters or networks for specific applications. Our Engineering Department is ready to assist you with your problems in the application of toroids.

Write to Dept. EL-40

**BARKER & WILLIAMSON, Inc.**

237 Fairfield Avenue

Upper Darby, Pa.

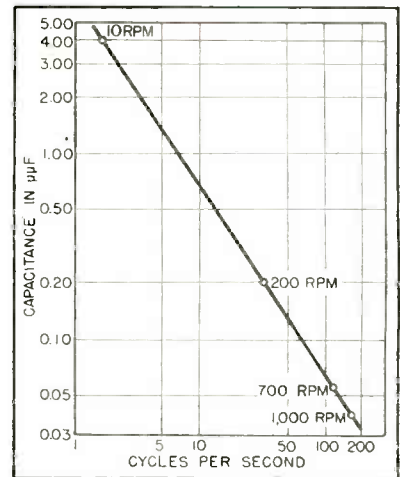

FIG. 3—Capacitance plotted against frequency

rect charging capacitance could be determined by means of this graph or the equation.

The relation between the actual angular velocity of the motor shaft and the current output of the capacitors was determined experimentally. A small motor whose speed could be varied in a stepless fashion was used to drive the current interrupter while the tachometer circuit was in operation. The rotational frequencies of the current interrupter were accurately determined with a revolution counter and a stop watch. In this fashion calibration curves were obtained for the four motors under consideration and are presented in Fig. 4 and 5.

The experimental data shown for the run made with the 10-rpm motor are included to illustrate the experimental spread in the determinations. The variance of the data

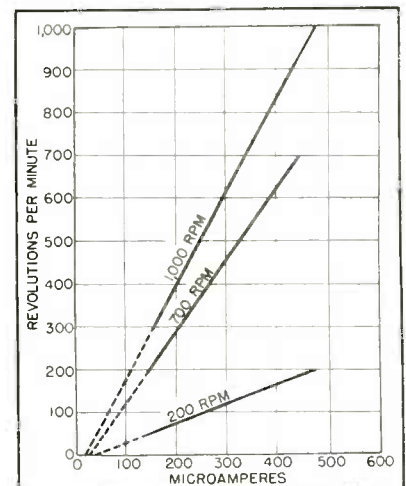

FIG. 4—Current and speed relations



# Fighting Death

## ON THE HIGHWAYS

### *Telechron Timing Motors Help Reduce Driving Hazards*

The careless driver is not solely to blame for the daily accident headlines. The driver whose vision or reactions are poor is another grave threat to safety on the nation's highways.

To keep the traffic accident rate to a minimum, the American Automobile Association has since 1936 conducted an intensive program of driver testing and training. Numerous testing devices — for color vision, finger reaction, foot reaction, etc. — are employed, not only to rate a driver's ability but to impress on him the necessity for "defensive driving" to guard against the other fellow's faults.

And since the appliances used to test human reactions must be accurate to a split-second, they are actuated by Telechron Timing Motors. *Instantly, constantly synchronous*, these famous motors respond with accurate, dependable performance — every time!

### *How's YOUR Timing?*

If the control or recording of variables is your problem, very likely a standard Telechron Motor is your answer. A Telechron application engineer, backed by the broadest experience in the field, can help you decide that. For greatest savings in time and money, consult him as *early* as possible in your planning. Meanwhile, send the coupon for quick facts. TELECHRON INC. A General Electric Affiliate.

# Telechron

ALL TELECHRON TIMING MOTORS ARE

INSTANTLY...CONSTANTLY SYNCHRONOUS

**TELECHRON INC.**  
40 Union Street  
Ashland, Massachusetts

Please send me information on sizes and types of Telechron Synchronous Motors. My possible application is:

- |                                     |                          |  |                          |
|-------------------------------------|--------------------------|--|--------------------------|
| Instruments                         | <input type="checkbox"/> | Communications Equipment                         | <input type="checkbox"/> |
| Timers                              | <input type="checkbox"/> | Other (please fill in)                           |                          |
| Electric Appliances                 | <input type="checkbox"/> | .....  |                          |
| Cost Recorders                      | <input type="checkbox"/> | .....  |                          |
| Advertising, Display Items          | <input type="checkbox"/> | .....  |                          |
| Juke Boxes                          | <input type="checkbox"/> | .....  |                          |
| Air Conditioning & Heating Controls | <input type="checkbox"/> | <input type="checkbox"/> Please send new Catalog |                          |

NAME.....  
COMPANY.....  
ADDRESS.....  
CITY..... ZONE.....  
STATE.....



It's easy to fit all TV circuits with

**GRACOIL**

"One Good Turn or a Million"

**TELEVISION**

**Transformers**



Vertical and Horizontal Blocking Oscillator. Below Chassis mounting

★ Order these Gracoil TV Transformers and get identical physical and electrical duplicates of original units used in all popular receivers. Used and endorsed by leading TV set manufacturers. Dependable. Trouble-free. We invite your inquiry. Write.



Vertical and Horizontal Blocking Oscillator. Above Chassis mounting



Plate and Filament Transformer with and without Magnetic Shielding



Vertical Deflection Output Transformer



Filter Choke

**THE GRAMER COMPANY**

Electrical Coils and Transformers

2734 N. PULASKI ROAD

CHICAGO 39, ILL., U.S.A.

ESTABLISHED IN 1935

**CO-AX AIR-SPACED ARTICULATED R.F. CABLES**

**4mm/ft**

**LOWEST EVER CAPACITANCE & ATTENUATION**

LOW ATTEN. TYPES	IMPED. OHMS	ATTEN. db/100 ft. at 100 Mc/s	LOADING db/100 ft. at 100 Mc/s	o.d.
A.1	74	1.7	0.11	0.36
A.2	74	1.3	0.24	0.44
A.34	73	0.6	1.5	0.85

FOR RADIO FREQUENCIES

LOW CAPAC. TYPES	CAPAC. mm/ft	IMPED. OHMS	ATTEN. db/100 ft. at 100 Mc/s	o.d.
C.1	7.3	150	2.5	0.36
P.C.1	10.2	132	3.1	0.36
C.11	6.3	173	3.2	0.36
C.2	6.3	171	2.15	0.44
C.22	5.5	184	2.8	0.44
C.3	5.4	197	1.9	0.64
C.33	4.8	220	2.4	0.64
C.44	4.1	252	2.1	1.03

FOR VIDEO and SPECIAL APPLICATIONS

We are specially organized to handle direct enquiries from overseas and can give IMMEDIATE DELIVERIES to U.S.A.

Cable your rush order for delivery by air. Settlement in dollars by check on your own bank. Transaction as simple as any local purchase and delivery just as quick.

**TRANSRADIO LTD**

CONTRACTORS TO H.M. GOVERNMENT.

CABLES: TRANSRAD · LONDON

138A CROMWELL ROAD

LONDON, S.W.7 ENGLAND

Paris  
International  
Trade  
Fair

FOUNDED 1904

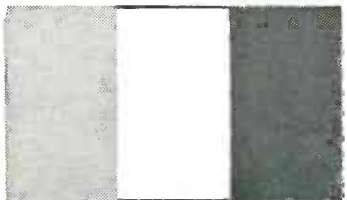

over 9,500 exhibitors from France and abroad

MAY 13 to MAY 29

Parc de la Foire de Paris  
Porte de Versailles  
Paris

Special Sections:  
ELECTRONIC MANUFACTURING,  
COMMUNICATIONS  
and  
INDUSTRIAL ELECTRONICS

**INFORMATION**

French Chamber of Commerce of the United States  
630 Fifth Ave. • New York 20, N. Y.



# REDESIGN TRIMS LENGTH 5¼ INCHES, CUTS UNIT COST \$5.70

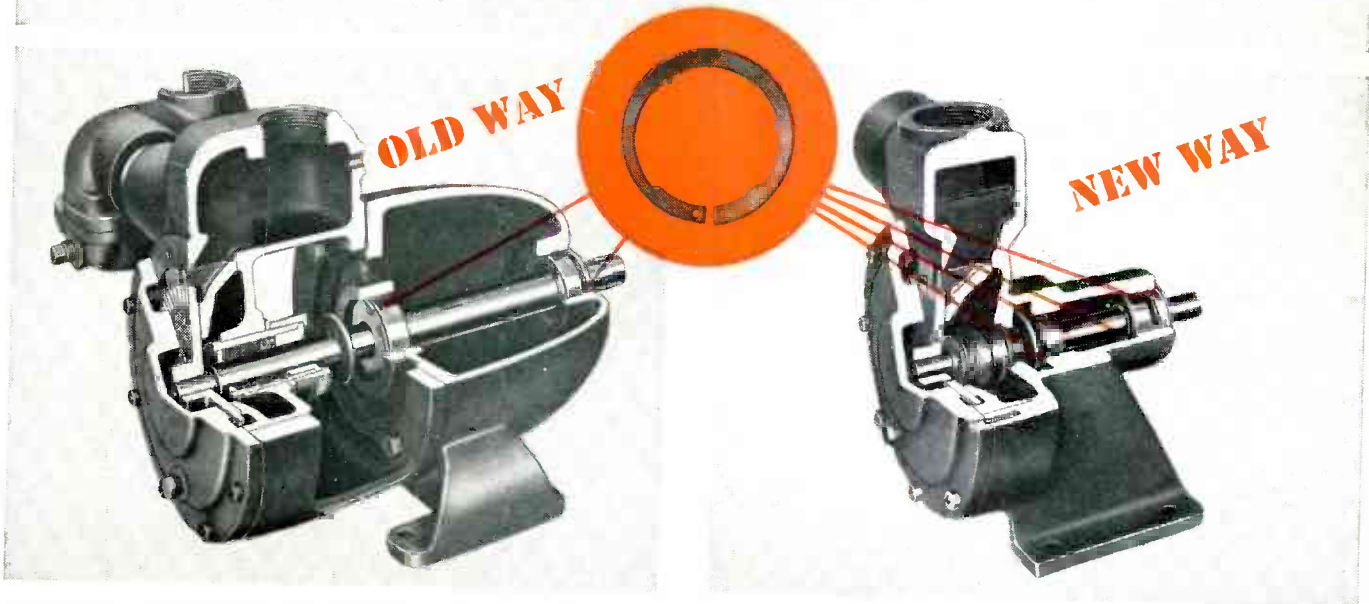

Series D Wayne water pump uses machined shoulders to position bearings on shaft. 2 Truarc rings hold bearings in housing. Locknut holds screw-type stuffing box that requires periodic tightening.

New design uses 4 Truarc Inverted rings (2 external, 2 internal) to position shaft, retain bearings. Inverted rings provide shoulders of uniform section height. 1 Standard ring secures maintenance-free mechanical seal.

Redesign with Truarc Rings helps save \$5.70 per unit for Wayne Home Equipment Company, Inc., Fort Wayne, Ind. It gives them a more compact product, eliminates a separate bearing pedestal and a skilled-labor grinding operation. It facilitates use of maintenance-free mechanical seal instead of old type stuffing box.

Redesign with Truarc Rings and you too will cut costs. Wherever you use machined shoulders, nuts, bolts, snap rings, cotter pins, there's a Truarc Ring that does a better job of holding parts together.

Truarc Rings are precision engineered. Quick and easy to assemble, disassemble. Always circular to give a never-failing grip. They can be used over and over again.

Find out what Truarc Rings can do for you. Send your blueprints to Waldes Truarc engineers for individual attention, without obligation.

See the Truarc Exhibit, Booth #1135, at the A.S.T.E. Show.

## REDESIGN WITH 5 TRUARC RINGS GIVES THESE BIG SAVINGS

- Cuts length 5¼ inches
- Cuts total labor 15.3%
- Eliminates skilled-labor grinding operation
- Saves 38.3% materials
- Allows use of stock-size shaft, smaller bearings
- Eliminates separate bearing pedestal

**TOTAL UNIT SAVING ... \$5.70**

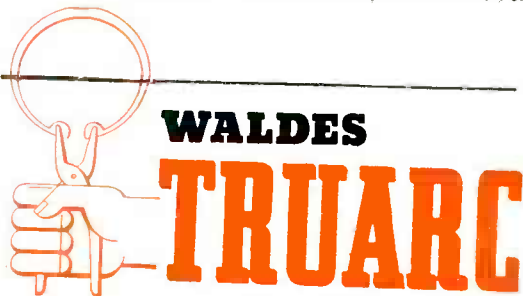

**WALDES  
TRUARC**

REG. U.S. PAT. OFF.

**RETAINING RINGS**

WALDES KOHINOOR, INC., LONG ISLAND CITY 1, NEW YORK

WALDES TRUARC RETAINING RINGS ARE PROTECTED BY U.S. PATS. 2,302,948; 2,026,454; 2,416,852 AND OTHER PATS. PEND.



Waldes Kohinoor, Inc., 47-16 Austel Place  
Long Island City 1, N. Y.

E-042

Please send 28-page Data Book on Waldes Truarc Retaining Rings.

Name \_\_\_\_\_

Title \_\_\_\_\_

Company \_\_\_\_\_

Business Address \_\_\_\_\_

City \_\_\_\_\_ Zone \_\_\_\_\_ State \_\_\_\_\_



Same  
Mounting  
as AC  
Contactor

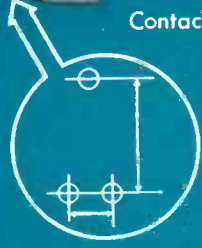

# New DC SOLENOID CONTACTORS

save installation time

## Unit construction — Fit standard AC mounting

Now, with this modern, compact solenoid-type contactor . . . you'll no longer have the nuisance of drilling special holes for each component and furnishing special insulation.

Ward Leonard's new Size 1, 2 and 3 DC Solenoid Contactors are *unit-insulated*—and have metal base plates which fit AC contactor dimensions.

Same accessibility of wiring as AC contactors . . . silver-to-silver contacts . . . components interchangeable with AC contactors.

Write for new Bulletin 1950. WARD LEONARD ELECTRIC CO., 31 South Street, Mount Vernon, N. Y. Offices in principal cities of U. S. and Canada.

**WARD LEONARD  
ELECTRIC COMPANY**  
*Result-Engineered Controls*  
RESISTORS • RHEOSTATS • RELAYS • CONTROL DEVICES

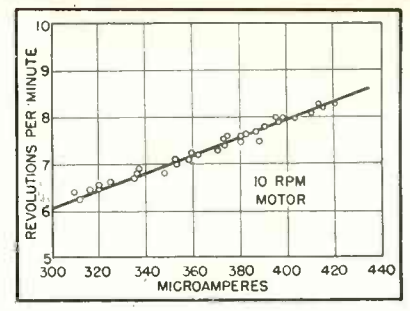

FIG. 5—Result of calibration run of tachometer

for the other motors was considerably less. In every case the curve drawn through the points was determined by application of the principle of least squares to the experimental data. The equations for the curves are all of the form  $I = I_0 + AR$  where  $R$  = revolutions per minute,  $I_0$  = leak current of 6H6 tube,  $A$  = slope of curve and  $I$  = current flow. The constants for this equation which apply to the various motors are found in the following table.

*Current-Speed Equation Constants*

Motor	$I_0$	$A$
10 rpm	14.9	52.0
200	30.5	2.24
700	22.8	0.599
1,000	15.0	0.464

Since the data obtained in the calibration run of the 10-rpm motor are the least consistent, the errors involved are the greatest. Calculations based on the thirty-three measurements shown in Fig. 5 indicate that for this series of measurements the most probable error in the current readings is 3.1 microamperes, or less than one percent. Acknowledgment is made to the Aluminum Company of America for financial assistance.

## One-Kilowatt Ultrasonic Generator

The principle of magnetostriction is employed in a low-frequency generator for ultrasonic applications developed by Mullar Electronic Products Ltd. of Britain.

The generator consists of a driving oscillator, power amplifier and low-voltage d-c power supply, together with necessary monitoring and check meters, and the transducer unit composed of a stack of



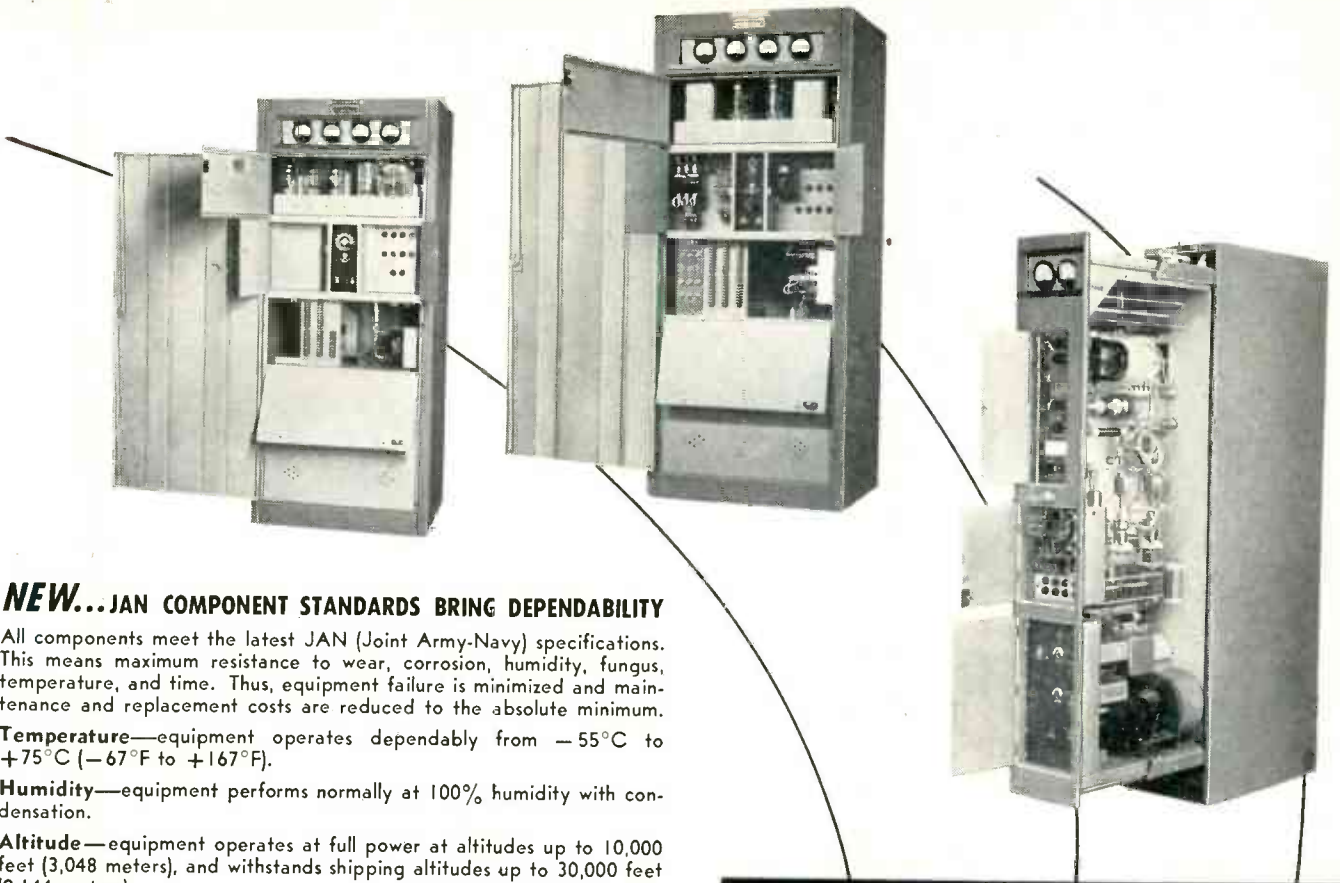

**NEW...JAN COMPONENT STANDARDS BRING DEPENDABILITY**

All components meet the latest JAN (Joint Army-Navy) specifications. This means maximum resistance to wear, corrosion, humidity, fungus, temperature, and time. Thus, equipment failure is minimized and maintenance and replacement costs are reduced to the absolute minimum.

**Temperature**—equipment operates dependably from  $-55^{\circ}\text{C}$  to  $+75^{\circ}\text{C}$  ( $-67^{\circ}\text{F}$  to  $+167^{\circ}\text{F}$ ).

**Humidity**—equipment performs normally at 100% humidity with condensation.

**Altitude**—equipment operates at full power at altitudes up to 10,000 feet (3,048 meters), and withstands shipping altitudes up to 30,000 feet (9,144 meters).

**NEW...UNIT CONSTRUCTION PROVIDES OPERATING FLEXIBILITY**

A flexible, multifrequency station can be formed from a combination of 96D and 96-200C Transmitters, one or two 50H Modulators and a 36D Rectifier. This provides for either simultaneous transmission on several frequencies or the selection of an individual frequency best suited to your particular communication problem.

**NEW...FRONT CONTROLS PROVIDE ADJUSTMENT CONVENIENCE**

All controls are located on the front of the transmitter; all R. F. stages and antenna tuning, under and overload and tone-keying adjustments, selection switch for external frequency shift excitation, rotary meter switch, exciter output control.

**NEW...DRAWER-TYPE CONSTRUCTION Means Easy Maintenance**

Ball bearing, drawer-type construction permits the transmitter to be quickly withdrawn from cabinet. All components are instantly accessible . . . no components are hidden or buried.

**WILCOX ANNOUNCES A**  
***COMPLETELY NEW***  
**96 Series**  
**Transmitting Station**  
**2-18 mc/s**      **2500 Watts**

**Write Today**  
 for complete information and specifications.

**WILCOX**  
**ELECTRIC COMPANY**  
 KANSAS CITY 1, MISSOURI • U. S. A.

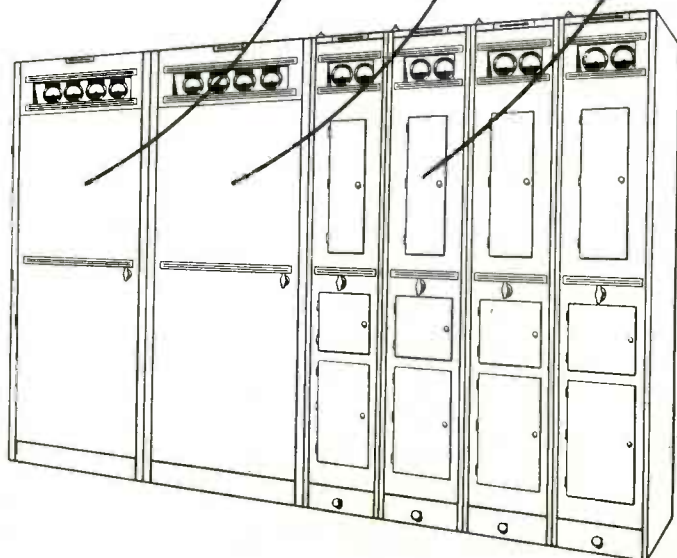

# Micro Ball Bearings

## Conrad Radial

The smaller  
the bearing  
the better  
it runs.

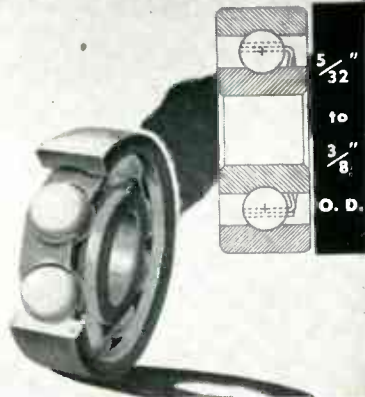

In American-made miniature sizes only Micro bearings have *ground* outer rings and raceways.

Write for your copy of Technical Bulletin No. 50 showing RADIAL (Conrad, extra light, and full race), Angular Contact, Self Aligning and Pivot Bearings 1/8" to 3/8" O.D.

**New Hampshire Ball Bearings, Inc.**

5 MAIN STREET • PETERBOROUGH, NEW HAMPSHIRE

**The GROUND Miniature Bearing**

## Portable Precision for the Field Engineer!

CONFORMS TO ALL REQUIREMENTS  
OF C63.2 RADIO NOISE METER  
SPECIFICATION ADOPTED  
BY AMERICAN STANDARDS  
ASSOCIATION, OCTOBER 26, 1949



### STODDART NM-20A RADIO INTERFERENCE AND FIELD INTENSITY METER

- A portable unit that you can **DEPEND** upon!
- Measures **FIELD INTENSITIES** of radio signals and r.f. disturbances using either a rod antenna or a rotatable loop antenna.
- **CONTINUOUS RANGE** 150 kc to 25-mc.
- **ONE MICROVOLT SENSITIVITY** as a two-terminal voltmeter; 2 microvolts-per-meter using rod antenna.
- Operates from self-contained dry batteries or external A.C. power unit.

Write for complete technical data

**STODDART AIRCRAFT RADIO CO.**

Main office and plant:  
6644 SANTA MONICA BLVD., HOLLYWOOD 38, CALIF., Phone: Hillside 9294

# WIND more COILS faster

WITH YOUR  
PRESENT  
COIL-WINDING  
MACHINE!

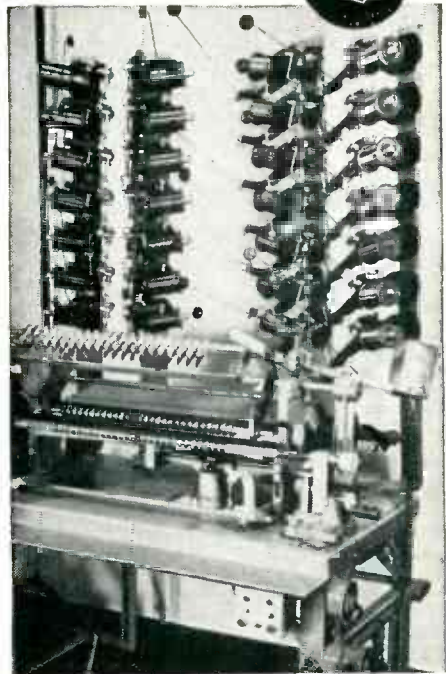

— use

## PAMARCO

Wire DeReeling Tensions  
for PERFECT COILS

Installation of these inexpensive PAMARCO tensions lowers winding costs because each machine will accommodate more coils at higher winding speeds. In addition to increased production, PAMARCO tensions raise production quality. Free-running action practically eliminates wire breakage and shorted turns. Simple thumb screw setting quickly adjusts for any wire gauge. No tools or special skill are needed for operation. For complete data call or write.

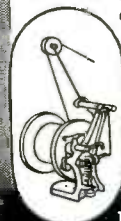

**PAPER MACHINERY  
& RESEARCH, INC.**

1014 OAK STREET  
ROSELLE, NEW JERSEY



THERMOPLASTIC INSULATED WIRE IN ALL SIZES

**105°C**  
PERFORMANCE  
UL APPROVED!

★ RESISTS SHRINK-BACK WHEN SOLDERED

★ RESISTS DEFORMATION

*...and More Megohms!*



★ MEETS JAN C76 LOW TEMPERATURE REQUIREMENTS

**SURCO**  
PRODUCTS  
MADE IN U.S.A.

*Surprenant*

MFG. CO.  
199 Washington St., Boston 8, Mass.



High Voltage Transformer for Testing Dielectric Strength—as seen in National's Research Laboratories.

## National's Continuous Research ... the answer to your Improved Profitable Products

National, not only carries on a continuing quality control program in the manufacture of National Vulcanized Fibre and Phenolite to assure adherence to rigid specifications, but, is constantly seeking improvements in these products for the advancement of industries where plastics practically perform.

### It will pay you to use—

**NATIONAL  
VULCANIZED  
FIBRE**

A tough, horn-like material with high dielectric and mechanical strength. Excellent machinability and forming qualities, great resistance to wear and abrasion, long life, light weight. Sheets, Rods, Tubes, Special Shapes.

**PHENOLITE**  
Laminated PLASTIC

About one-half the weight of aluminum, possesses an unusual combination of properties—a good electrical insulator, great mechanical strength, high resistance to moisture; ready machinability. Sheets, Rods, Tubes, Special Shapes.

*National Research and Engineering Service are available to you, without obligation—to help you solve your specific development problem. Write us—*

**NATIONAL VULCANIZED FIBRE CO.**

WILMINGTON

Offices in



Since 1873

DELAWARE

Principal Cities

nickel laminations wound with a common coil for excitation and polarization. The amplifier drives the transducer and delivers a maximum output of 1 kilowatt over a frequency range of 10 kc to 25 kc.

The magnetostriction transducer is composed of a stack of nickel laminations somewhat resembling a transformer core. The insulation of this unit is such that the complete transducer may be immersed in conductive liquids without fear of damage or electrical shock. In practice the transducer can quite easily be clamped against the side of the treatment bath. Alternatively it can be fitted in a pipe junction, thus enabling the liquid to be treated as it flows over the actuating face. With simple cooling arrangements, a loading of about 5 watts per square centimeter can normally be used.

The maximum dimensional change, and therefore the maximum transfer of electric to ultrasonic energy, is obtained when the magnetostriction element is excited at its natural frequency. For this reason it is necessary to provide different transducers if the frequency of excitation is changed. The transducers at present available cover the standard frequencies 15, 20 and 25 kc.

The generator is rack-mounted for ease of service, and the controls are simplified for operation by semi-skilled labor. Continuous operation is possible at peak power over the frequency range.

Since the velocity of sound in nickel varies with the temperature and the magnetic field—and this in turn affects the natural frequency

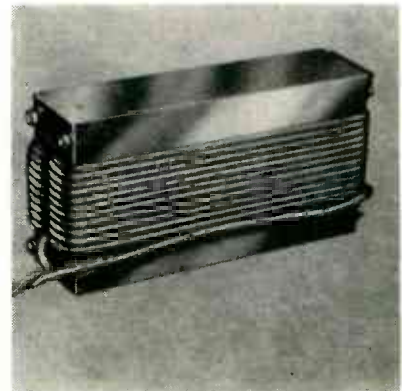

Low-frequency magnetostriction transducer



PRODUCED BY THE MILLIONS



Final Inspection



Hi-Q Components

- and every single one is Individually Tested!

# Hi-Q COMPONENTS

Capacitors  
Trimmers • Choke Coils  
Wire Wound Resistors

## BETTER 4 WAYS

- ✓ PRECISION
- ✓ UNIFORMITY
- ✓ DEPENDABILITY
- ✓ MINIATURIZATION

Though **Hi-Q** Ceramic Components are produced at a rate of several million a month, each and every single one is individually tested at each stage of production and as a part of final inspection before shipment. That is one of the reasons why you can depend on all **Hi-Q** Components to precisely meet specifications, ratings and tolerances. That is one of the reasons why they are used by virtually all leading producers of television, communications and electronic equipment.

You are invited to write now for a copy of the brand new **Hi-Q** Datalog just off the press.

JOBBERS—ADDRESS: 740 Belleville Ave., New Bedford, Mass.

# Hi-Q

## Electrical Reactance Corp.

FRANKLINVILLE, N. Y.

SALES OFFICES: New York, Philadelphia, Detroit, Chicago, Los Angeles

PLANTS: Franklinville, N. Y., Jessup, Pa., Myrtle Beach, S. C.

EXPORT ADDRESS: 41 E. 42nd St., New York 17, N. Y., U. S. A.



### for School and Industrial Laboratories

- A unit designed by Vickers Electric Division to help students and industrial personnel obtain a wider knowledge of the characteristics and applications of high-performance self-saturating magnetic amplifiers.
- All three basic single-phase self-saturating circuits may be studied, and the educational unit can actually be used in operating controls circuits. Gives d-c or a-c output, uses d-c or a-c control power.
- Magnetic Amplifier Laboratory Manuals and Magnetic Amplifier Design Bulletins included with each educational unit.

Write for information and price.



**VICKERS ELECTRIC DIVISION**

VICKERS Inc.  
1801 LOCUST STREET • ST. LOUIS 3, MISSOURI

## 2 KW VACUUM TUBE BOMBARDER OR INDUCTION HEATING UNIT



For Only \$650.

Never before a value like this new 2-KW bench model "Bombarder" or high frequency induction heater . . . for saving time and money in surface hardening, brazing, soldering, annealing and many other heat treating operations.

Simple . . . Easy to Operate . . .  
Economical Standardization of  
Unit Makes This New Low Price  
Possible

This compact induction heater saves space, yet performs with high efficiency. Operates from 220-volt line. Complete with foot switch and one heating coil made to customer's requirements. Send samples of work wanted. We will advise time cycle required for your particular job. Cost, complete, only \$650. Immediate delivery from stock.

Scientific Electric Electronic Heaters are made in the following range of Power: 1-2-3½-5-7½-10-12½-15-18-25-40-60-80-100-250KW.

*Scientific  
Electric*

Division of

"S" CORRUGATED QUENCHED GAP CO.

107 Monroe St., Garfield, N. J.



## SPECIALTY DRY BATTERIES

### Custom Built to Exacting Industrial and Electronic Requirements

Whatever the unusual purpose or requirements of the dry battery you want, Specialty Battery Company can help you. We specialize in supplying hard-to-get dry batteries for thousands of special uses. We can also design and produce a Specialty battery to your own specifications.

#### Write For our Catalog

Save time and trouble. Use this catalog's complete listing and descriptions to find exactly the battery you need for any conceivable purpose.



**SPECIALTY BATTERY COMPANY**

A SUBSIDIARY OF THE

**RAY-O-VAC**

RAY-O-VAC COMPANY

MADISON 3, WISCONSIN



No *"breakdown"* even after roughest handling, with this new insulation

# BH "649"

What does insulation breakdown cost you? . . . In customers "sour'd" on your product? In salesmen explaining, instead of selling your line? In excessive maintenance?

BH "649" Fiberglas Tubing and Sleeving is proof that insulation can be toughened against abrasion. Even after rough handling and severe bending, BH "649" retains its rated dielectric strength.

BH "649" stays supple after baking 12 hours at 300°F. No flowing, softening or blistering after 15 minutes at 425°F. Basic Fiberglas braid (1200°F) unaffected by aging.

You get this superior Fiberglas insulation at the price of ordinary cotton-base or rayon-base insulation. Often a less expensive grade of insulation can be used since there is little or no loss of dielectric strength in assembly or product use.

BH "649" is made in Grades A-1, B-1, C-1 and C-2—in all sizes from No. 24 to 5/8" inclusive. Samples furnished gladly on request.

BENTLEY, HARRIS MANUFACTURING CO., CONSHOHOCKEN, PA.

## BH *Fiberglas*\* SLEEVINGS



**KNOT IT . . .** Take a length of BH "649". Knot it. Pull it as tight as you can. Twist it. Then loosen the knot. There is no cracking. No change in the dielectric strength.

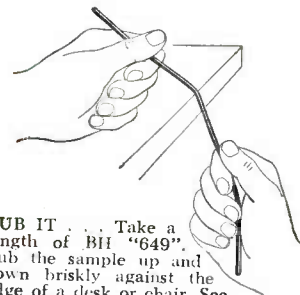

**RUB IT . . .** Take a length of BH "649". Rub the sample up and down briskly against the edge of a desk or chair. See how difficult it is to damage the coating.



**HOLD A MATCH UNDER IT . . .** Take a length of BH "649". Hold a lighted match under it. BH "649" will not support combustion.

### COUPON

Bentley, Harris Mfg. Co., Dept. E-40, Conshohocken, Pa.

I am interested in BH "649" Fiberglas Tubing and Sleeving. Send samples for production testing of Grade \_\_\_\_\_ in sizes as follows \_\_\_\_\_ for \_\_\_\_\_ operating at temperatures of \_\_\_\_\_°F. at \_\_\_\_\_ volts. (size or I.D.) (product)

NAME \_\_\_\_\_

ADDRESS \_\_\_\_\_

Send samples, pamphlets and prices on other BH Products as follows:

- BH non-fraying Fiberglas Sleeving
- Cotton or Rayon-base Sleeving and Tubing

# you get MORE PERFORMANCE for LESS MONEY with the NEW Browning OSCILLOSYNCHROSCOPE



**MODEL  
ON-5**

For only  
**\$485.00**

this new five-inch Browning 'scope gives you the basic laboratory equipment for pulse work — in a single, compact unit with:

- Triggered sweep rate continuously variable from 1.0 to 25,000 microseconds per inch.
- Sawtooth sweep rate 10 cycles to 100 KC.
- Sweep calibration (triggered and sawtooth) in microseconds per screen division accurate to  $\pm 10\%$ .
- Vertical amplifier flat within 3 db. from 5 cycles to 5 megacycles.
- Sensitivity 0.075 volts RMS per inch.
- Horizontal amplifier d.c. to 500 KC, sensitivity 2 volts per inch.
- Self-calibrating on both X and Y axis.
- Readily portable . . . weighs but 50 pounds.

## plus these ELECTRICAL and MECHANICAL features

- 5UP1 cathode-ray tube operates at accelerating potential of 2600 volts
- Sweep starting time is approximately 0.1 microsecond
- Sweep may be triggered or synchronized by positive or negative sine-wave or pulse signals of 0.5 volts (external) or 0.75 inches deflection (from vertical amplifier)
- Three-step attenuator — 100:1, 10:1, and 1:1, plus continuous adjustability over entire range
- Peak-to-peak vertical calibration voltages of 0.2-20-200 at accuracy of  $\pm 10\%$
- Cathode connection, brought out to front panel, allows external blanking and marker connection
- All deflection plates are available for direct connection
- Steel cabinet finished in black wrinkle
- Steel panel finished in black leatherette
- Copper-plated steel chassis with lacquer finish
- Controls grouped by function for operating convenience
- Free-view screen has graduated X- and Y-axis scales
- Size: 10" wide, 14½" high, 16¾" deep
- Instrument draws 180 volt-amperes at 115 volts 60 cycles.

NET PRICE, F.O.B. Winchester, Mass. . . . . \$485.00

**FREE BULLETIN** gives further data on this new, low-cost, versatile oscillosynchroscope. Ask for data sheet ON-54E.

In Canada, address Measurement Engineering Ltd., Arnprior, Ontario

Export Sales  
Rockefeller Plaza  
Room 1422  
New York 20



**BROWNING**  
Laboratories, Inc.  
Winchester, Mass.  
ENGINEERED FOR ENGINEERS

TUBES AT WORK

(continued)



Driver stages and power supply of the generator. The tray mounted on the transducer is used for emulsification

of the transducer—it is sometimes necessary to make a small adjustment to the generator frequency. For this reason a variable-frequency source of power is provided.

The transducer employed in the Mullard equipment offers scope for work in the metallurgical field in the mixing of powdered and molten metals in alloy production. It is possible that the equipment could also be used for speeding up the process of solidification in molten tin and aluminum, and for the tinning of aluminum and similar metals.

Emulsification of a number of liquids and the precipitation or dispersion of particles in suspension are further possibilities of ultrasonics receiving attention. A certain amount of success is reported in cleansing and washing applications, especially with cotton and rayon waste. It is not only possible to produce a much higher degree of cleansing, but it is also possible to reduce the time of treatment.

### Simple Deviation Limiter

BY VIRGIL M. BRITAIN  
Radio Specialty Mfg. Co.  
Portland, Oregon

To LIMIT the frequency deviation produced by a phase-modulated transmitter, it is necessary to limit the slope of the audio-frequency wave applied to the phase modulator.

A method of slope limiting which



YOU CAN BE **SURE**.. IF IT'S  
**Westinghouse**

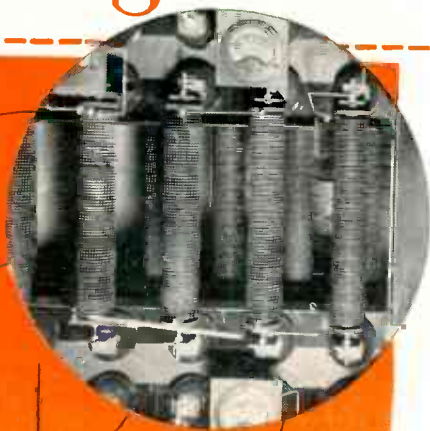

# No Program Interruptions

**How KDKA MAKES SURE  
with Selenium Rectifiers**

You, too, can have a power rectifier that is good for the *life* of your transmitter. Gone forever will be those costly program interruptions caused by the sudden necessity of replacing power tubes.

Since Selenium stacks were installed at KDKA, power rectifiers are no longer critical components. In addition to many years of service, these Selenium rectifiers provide other benefits. No warm-up period or filament power required . . . ability to withstand relatively high inverse surges . . . takes temporary or prolonged overloads without damage.

Why not be assured of stable operation of your power rectifier . . . of program continuity at full signal strength. Your nearby Westinghouse representative will tell you how to get the job-proved Rectox. Ask him for a copy of DB-19-025 or write Westinghouse Electric Corporation, Post Office Box 868, Pittsburgh 30, Pa. J-21568

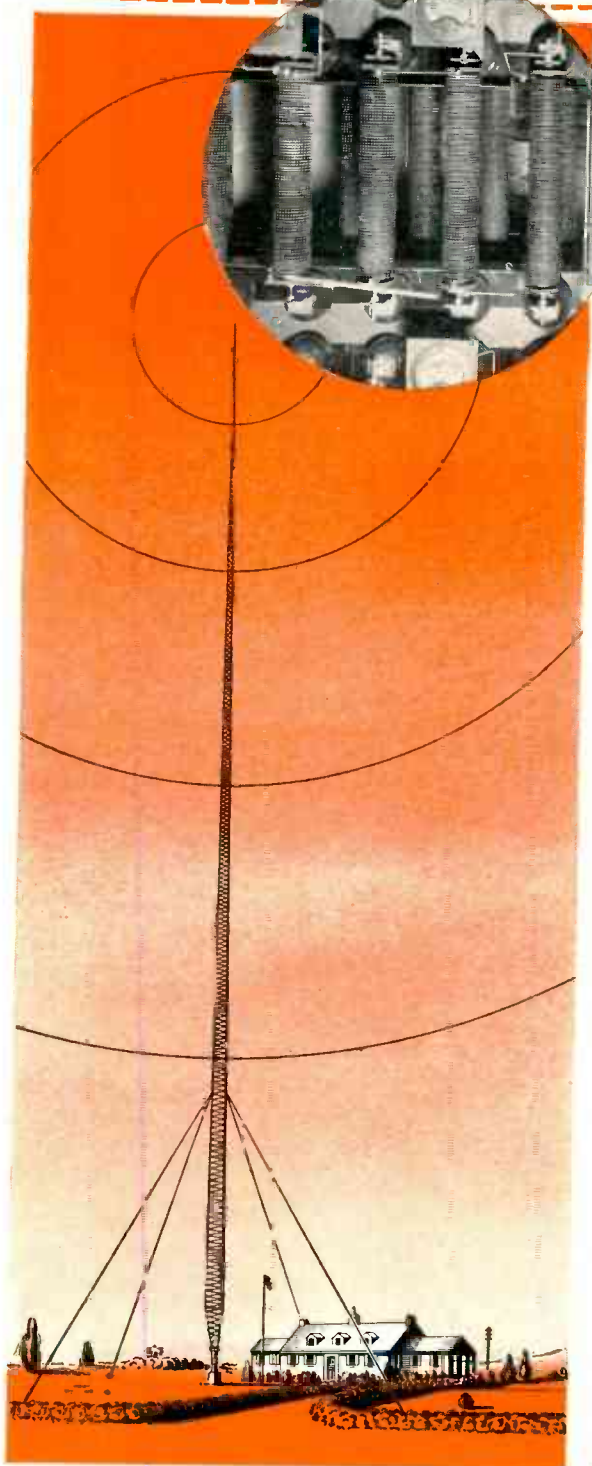

**Westinghouse**  
*Rectox*

**Rectifiers & Chargers for  
ALL INDUSTRIES**

# ERIE RESISTOR CORP. PRODUCTS

- CERAMICON TRIMMERS

Styles TS2A—TD2A—532 & 557 in all standard values

- SILVER BUTTON MICA CAPACITORS

Styles: FA—CB—and others

- CERAMICON and GP CAPACITORS

NP0—N080—N330—N750 in stock

- DISC CERAMICON

Styles: 811 and 821

- FEED-THRU CERAMICON

Style 362 and others

We are still continuing to supply our customers with "rare" and much needed Resistors and J Potentiometers.

## LEGRI S CO. INC.

130 West 102nd Street

New York 25, N. Y.

Telephone: ACademy 2-0018

### REQUIREMENTS:

✓	0.15 $\mu$ sec. Pulse Width
✓	25,000 Volts Max.
✓	Controlled Rise and Decay Time
✓	10% Slope of Pulse Top
✓	Oil-Filled & Hermetic Sealed
✓	Expansion Bellows

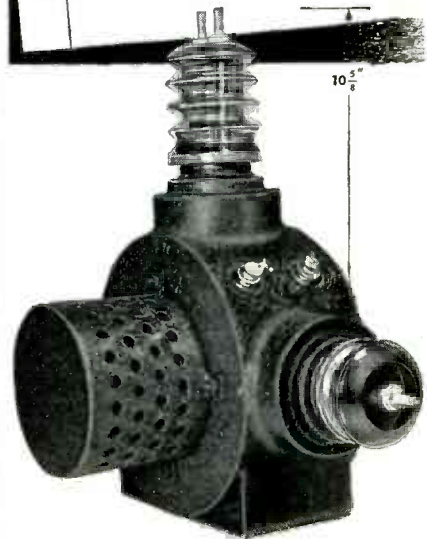

## SOURCE:

**FOR HIGHLY SPECIALIZED APPLICATIONS  
THE TRANSFORMER  
SOURCE IS SPERRY**

Vacuum - impregnated, HIPERSIL core, open or cased transformers to meet exacting electrical requirements in any given case size. Special design skills, premium materials, painstaking manufacture of custom units. If you have a transformer problem, consult us immediately.

**WRITE FOR SPECIFICATION FORMS TO FACILITATE NEGOTIATION SERVICE.**



**SPERRY PRODUCTS, INC.  
DANBURY, CONN.  
TELEPHONE: DANBURY 4000**

# AMPERITE

THERMOSTATIC METAL TYPE

## Delay Relays



**PROVIDE DELAYS RANGING FROM 1 TO 120-SECONDS**

**FEATURES:** — Compensated for ambient temperature changes from  $-40^{\circ}$  to  $110^{\circ}$  F . . . Hermetically sealed; not affected by altitude, moisture or other climate changes . . . Explosion-proof . . . Octal radio base . . . Compact, light, rugged, inexpensive . . . Circuits available: SPST Normally Open; SPST Normally Closed.

**PROBLEM?** Send for "Special Problem Sheet"

## Regulators

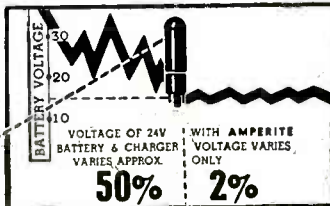

Amperite REGULATORS are the simplest, lightest,

cheapest, and most compact method of obtaining current or voltage regulation . . . For currents of .060 to 6 Amps. . . Hermetically sealed; not affected by altitude, ambient temperature, humidity.

Write for 4-page Illustrated Bulletin.

**AMPERITE CO., Inc., 561 Broadway, New York 12, N. Y.**

In Canada: Atlas Radio Corp., Ltd., 560 King St., W. Toronto



# Federated ROSIN CORE SOLDER

Look for the orange package . . . the universally popular solder for use in electrical applications where bonding must be secure and free from corrosion.

The flux is in the solder . . . all you need is heat! Federated Rosin Core Solder is available in 1, 5, and 20-pound sizes.



Federated makes every commercial solder . . . Asarco Body Filler Metal, acid-core, solid wire, spray-gun, and bar . . . purity and composition guaranteed by the world's leading supplier of solder.

**Federated METALS**  
 Division of AMERICAN SMELTING AND REFINING COMPANY  
 120 Broadway, New York 5, N. Y.  
 OFFICES IN PRINCIPAL CITIES ACROSS THE NATION



# WHEN YOU WANT A MINIATURE CARTRIDGE

With  
*Exceptionally* **SMOOTH RESPONSE**

CHECK

*Astatic's* **NEW . . .**  
**"AC" SERIES CRYSTAL CARTRIDGES**

● Astatic engineers have accomplished—in their tiny new "AC" Series Crystal Cartridges—a mechanical drive system with a new low in inertia. It's the primary source of a new degree of smoothness of response. You will also note new tracking excellence and low needle talk—also partially due to the drive system. Overall excellence of frequency response is particularly superior in the high frequencies. If you have not already done so, by all means check the perfection of sound reproduction which these advanced little cartridges are capable of delivering.

"AC" Series Cartridges weigh approximately five grams and are about 5/16" thick x 1/2" high x 1-1/2" long, not including pins. They are available in double needle turnover or single needle models, the latter in choice of three-mil stylus tip for 78 RPM, one-mil for 33-1/3 or 45, or with special Astatic All-Groove tip for all record types. Astatic's exclusive Type "C" Taper-Lock Needle, easily changeable without tools, is used throughout. Housings are of molded Bakelite, with metal mounting brackets (fit standard 1/2" mounting center) and needle guards. Write for complete specifications.

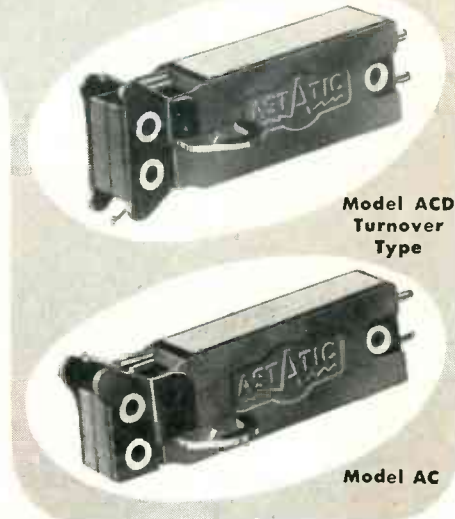

### Changing the Type "C" Taper-Lock Needle

Placing thumbnail against stub at rear of needle (A), simply push in direction of arrow to remove. To insert, fold card, on which new needle comes, along scored line; place narrow end of needle shank in wide end of metal cartridge groove (B) and pull card in direction of arrow.

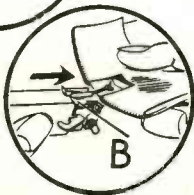

Astatic Crystal Devices manufactured under Brush Development Co. patents



TUBES AT WORK

(continued)

consists of differentiating the audio-frequency wave, clipping the voltage peaks from that wave, and then integrating the clipped wave, as described in a recent article.<sup>1</sup>

A somewhat simpler method of slope limiting which is suitable for use as a deviation limiter in phase-modulated transmitters is illustrated in Fig. 1. This method uses neither differentiating nor integrating circuits, and the circuit loss is comparatively low when limiting does not occur.

The principle of operation of the device depends upon the current and voltage relationships in a capacitance. These are expressed by the equation  $i = C (de/dt)$ .

In the equation, it is seen that the current and the derivative of

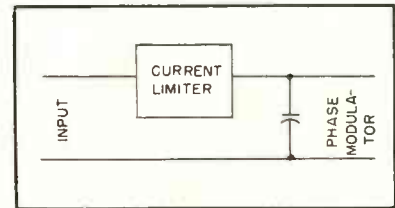

FIG. 1—Basic circuit for limiting current to a capacitor

the voltage wave are linearly related. Since the derivative of the voltage wave is the slope of the voltage wave, the maximum value of the slope may be limited by simply limiting the current flowing in the capacitance to an appropriate maximum value. This leads to a basic circuit as shown in Fig. 1.

A practical form of the circuit is shown in Fig. 2. The constants of the circuit are such that the twin diode is actually a current limiter; current limiters such as this are frequently used to produce a clipped voltage wave by passing the limited current through a resistive network and utilizing the voltage developed across a resistor by the limited current; however in this case it can be shown by means of an oscilloscope that clipped voltage waves do not exist in the circuit.

When no limiting occurs, the output voltage is only slightly less than the input voltage, and there is very little, if any, phase shift in the circuit.

The device functions very satis-



# Choice of the Elite!



• After comprehensive examinations and tests, the most outstanding men in airline operations and communications have almost without exception specified the Collins 51R aircraft receiver for navigational use of the omnidirectional range.

By their choice, nearly all major United States airlines have installed or soon will install this efficient, trustworthy receiver and accessory instrumentation, to take full advantage of the new VHF radio facilities with which most of America's airways are now equipped.

The Collins 51R equipment and its companion VHF airborne transmitter, the Collins 17L, are also providing up-to-the-minute navigation and communications in an increasing number of private and business planes. Write us today for descriptive bulletins.

## COLLINS 51R SPECIFIED FOR:

- American Airlines
- Capital Airlines
- Chicago and Southern Air Lines
- Colonial Airlines
- Continental Air Lines
- Eastern Air Lines
- National Airlines
- Northwest Airlines
- Pan American World Airways System
- Robinson Airlines
- Transcontinental & Western Air
- United Air Lines



Robinson Airlines



IN AVIATION RADIO, IT'S...



**COLLINS RADIO COMPANY, Cedar Rapids, Iowa**

11 West 42nd Street  
NEW YORK 18

2700 West Olive Avenue  
BURBANK

# Large or Small

## SQUARE, ROUND OR RECTANGULAR PAPER TUBES

### FOR COIL WINDING



SEND FOR ARBOR LIST  
OF OVER 1000 SIZES

Inside Perimeters from .592" to 19"

With specialized experience and automatic equipment, PARAMOUNT produces a wide range of spiral wound paper tubes to meet every need... from 1/2' to 30' long, from .592" to 19" inside perimeter, including many odd sizes of square and rectangular tubes. Used by leading manufacturers. *Hi-Dielectric, Hi-Strength.* Kraft, Fish Paper, Red Rope, or any combination, wound on automatic machines. Tolerances plus or minus .002". Made to your specifications or engineered for YOU.

## Paramount PAPER TUBE CORP.

616 LAFAYETTE ST., FORT WAYNE 2, IND.

Manufacturers of Paper Tubing for the Electrical Industry

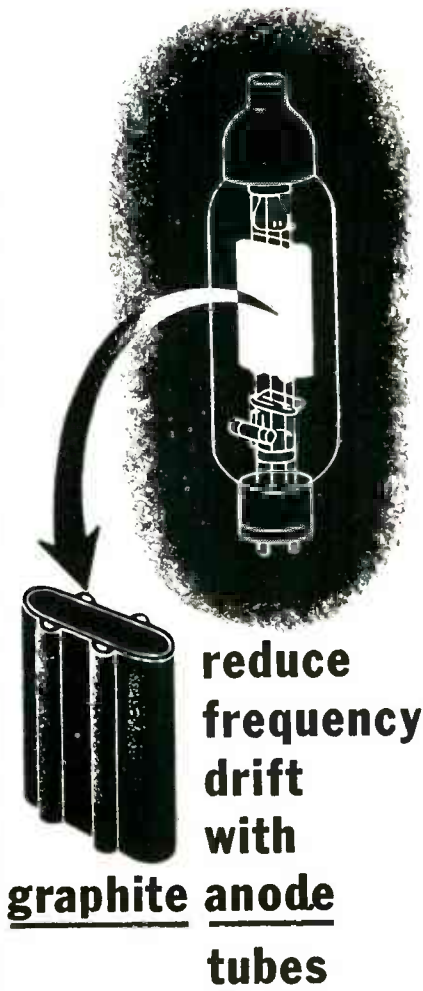

reduce  
frequency  
drift  
with  
graphite anode  
tubes

Frequency drift from short wave and FM transmitters, diathermy and electronic heating machines can be reduced with graphite anode oscillators.

And when tubes are equipped with non-warping Speer graphite anodes, frequency drift reaches a new low — stability of inter-electrode capacitances is assured — warping in other tube elements is inhibited.

In other vacuum tubes — power, rectifier and modulator, Speer graphite anodes impart these characteristics which cannot be obtained through the use of any other type anode. Try graphite anode tubes in your equipment and you'll see why the current trend is to graphite.

Look for graphite anodes when you're looking for better tubes.

### Build YOUR OWN Heathkit TEST EQUIPMENT

**Heathkit AUDIO GEN. KIT** \$34.50

**Heathkit TELEVISION GENERATOR KIT** \$39.50

**Heathkit SIGNAL TRACER KIT** \$19.50

**Heathkit CONDENSER CHECKER KIT** \$19.50

**NEW Heathkit IMPEDANCE BRIDGE SET** \$69.50

**NEW Heathkit HAND TESTER KIT** \$13.50

**Heathkit TUBE CHECKER KIT** \$29.50

**Heathkit 5" OSCILLOSCOPE KIT** \$39.50

**Heathkit BATTERY ELIMINATOR KIT** \$22.50

**Heathkit ELECTRONIC SWITCH KIT** \$34.50

**Heathkit R.F. SIGNAL GEN. KIT** \$19.50

**Heathkit VACUUM TUBE VOLTMETER KIT** \$24.50

Heathkits are beautiful factory engineered quality service instruments supplied unassembled. The builder not only saves the assembly labor cost but learns a great deal about the construction and features of the instrument. This knowledge aids materially in the use and maintenance of the equipment. Heathkits are ideal for and used by leading universities and schools throughout the United States. Each kit is complete with cabinet, 110V 60 cycle transformer (except Handi-Tester), all tubes, coils assembled and calibrated, panel already printed, chassis all punched, formed and plated, every part supplied. Each kit is provided with detailed instruction manual for assembly and use. Heathkits provide the perfect solution to the problem of affording complete service equipment on a limited budget. Write for complete catalog.

## HEATH COMPANY

BENTON HARBOR, 14 MICHIGAN

EXPORT DEPARTMENT  
13 EAST 40TH STREET  
NEW YORK 16, N.Y.  
CABLE — ARLAB — N.Y.



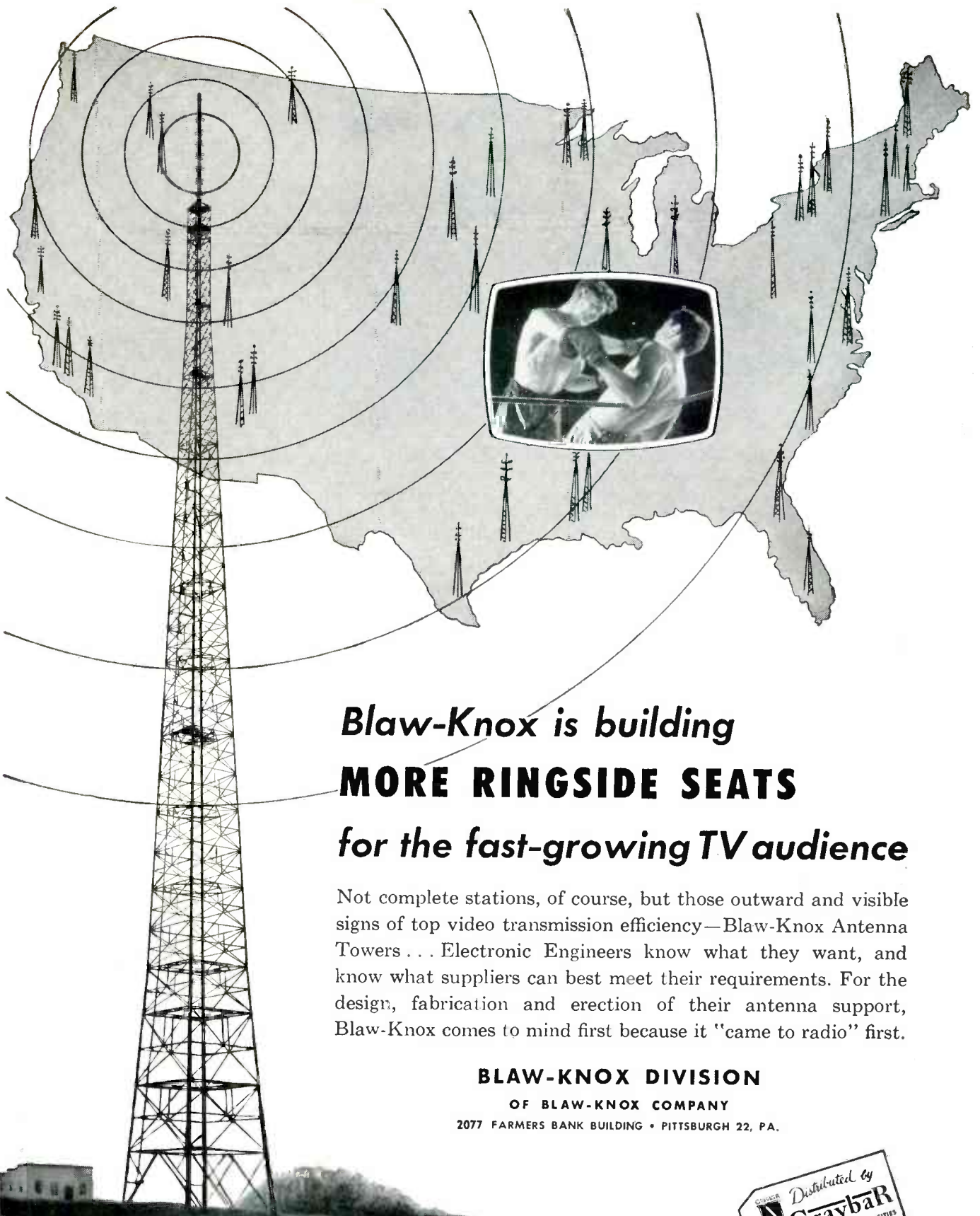

*Blaw-Knox is building*  
**MORE RINGSIDE SEATS**  
*for the fast-growing TV audience*

Not complete stations, of course, but those outward and visible signs of top video transmission efficiency—Blaw-Knox Antenna Towers... Electronic Engineers know what they want, and know what suppliers can best meet their requirements. For the design, fabrication and erection of their antenna support, Blaw-Knox comes to mind first because it "came to radio" first.

**BLAW-KNOX DIVISION**

OF BLAW-KNOX COMPANY

2077 FARMERS BANK BUILDING • PITTSBURGH 22, PA.



**BLAW-KNOX ANTENNA TOWERS**

# VARIAN MICROWAVE ENGINEERING

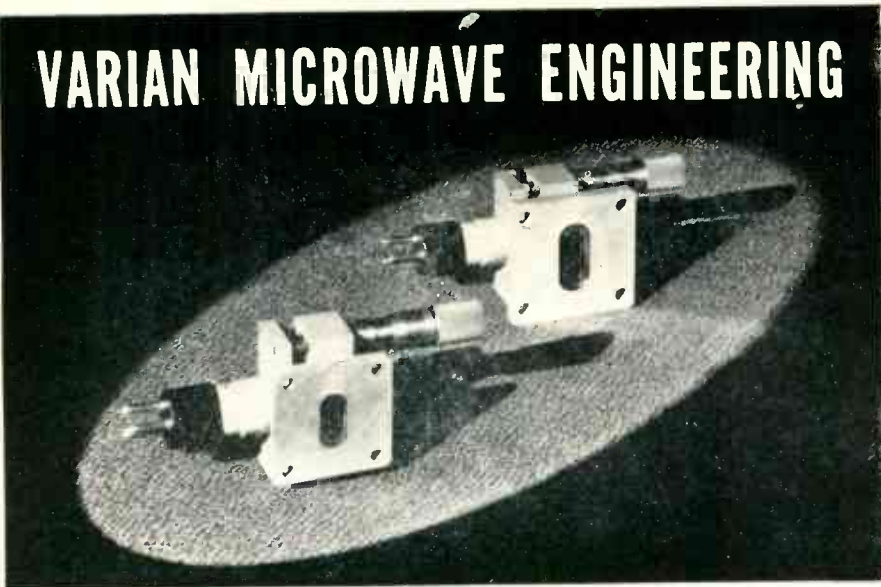

## TWO NEW WAVEGUIDE-OUTPUT REFLEX KLYSTRONS

Varian engineered to tune over the frequency range from 8,100 to 17,500 megacycles. These tubes are designed for transmitter service, for use as local oscillators and bench oscillators as a power source for measurements. The tubes are small, light and sturdily built. Flanges with mica windows bolt directly to the waveguide with a lapped surface to avoid reflections and leakage. Special grid techniques increase efficiency, reduce microphonics. A single screw tuner covers the entire broad tuning range.

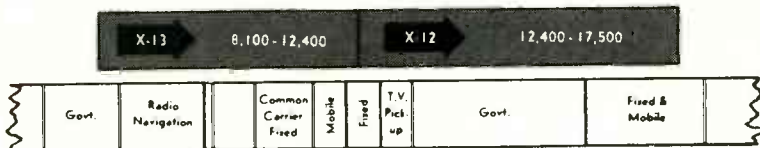

### Electrical Characteristics

	X-13	X-12
Beam Voltage	500 volts, max	600 volts, max
Beam Current	60 ma, max	60 ma, max
Heater Voltage	6.3 volts	6.3 volts
Heater Current	1.1 amp	1.1 amp
Reflector Voltage	0 to -1000 volts	0 to -1000 volts
Tuning Range	8,100-12,400 mc min	12,400-17,500 mc min
Power Output	100 milliwatts, min with transformer	10 to 100 milliwatts

### Mechanical Specifications

	X-13	X-12
Cathode	Oxide coated, unipotential	Oxide coated, unipotential
Clearance dimensions	3½ x 2½ x 2½ in.	3½ x 2½ x 2½ in.
Weight	6 ounces	5 ounces
Output Flange	Mates with standard flange for 1 x ½ x 0.050 in. waveguide	Mates with standard flange for 0.702 x 0.391 x 0.040 in. waveguide
Cooling	Forced air cooling required for beam power inputs exceeding 10 watts	Forced air cooling required for beam power inputs exceeding 10 watts
Mounting position	Any	Any

### Typical Operation

	X-13	X-12
Frequency	10,000 mc	16,000 mc
Beam Voltage	400 volts	600 volts
Beam Current	48 ma	50 ma
Reflector Voltage	575 volts	280 volts
Power Output	230 milliwatts	25 milliwatts
Load VSWR	Less than 1.1	
Modulation Bandwidth	30 mc	50 mc
Temperature coefficient	Less than 0.25 mc per degree C	

Not illustrated, X-21 klystron. Five-watt two-cavity oscillator. Weight approximately 4½ ounces. Specifications upon request.

**VARIAN**  
associates

99 washington st.  
san carlos, calif.

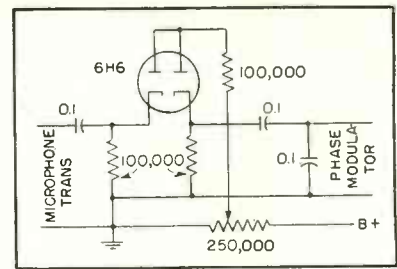

FIG. 2—Practical circuit of deviation limiter

factorily in limiting deviation in a phase-modulated transmitter of the type used for mobile radiotelephone service.

### REFERENCE

(1) Marion R. Winkler, Instantaneous Deviation Control, *ELECTRONICS*, p 97, Sept. 1949.

## Computer Simulates Flight

Flight characteristics and control equipment of an aircraft can be checked prior to its construction on a calculator known as the flight simulator. With it, MIT engineers will be able to set up an electrical model of any aircraft which is in an advanced stage of design and then apply an actual autopilot to fly this nonexistent, theoretical craft.

The autopilot then has exactly the same problem that it would have in the actual flight of the missile or airplane, were the prototype built. Thus the simulator flight



Computer panel where characteristics of the plane are set up contains electronic elements for adding, multiplying and integrating



# Driver-Harris

perfects

new alloy for

**WESTINGHOUSE** lamps



## HERE WAS THE PROBLEM:

How to obtain a strong, rigid assembly for conductors supporting the filaments of sealed beam automobile headlights and, at the same time, make a perfect seal between the conductors and the glass housing of the lamp, so that gas sealed within the lamp might not escape.

## AND HERE'S THE SOLUTION:

The back wall of the lamp, cast from Pyrex-like glass, has three holes through which the conductors can be passed. The area around these holes is heated until the glass is near-molten. Over each hole, on the rear side of the lamp, is then placed a "thimble"—made of *specialty produced* D-H alloy. These thimbles are pressed into the molten glass, which, upon cooling, holds them firmly in position. The conductors are then passed through the holes in the glass wall, and their free ends soldered to the base of each thimble respectively. Lugs soldered to the thimbles, outside, provide terminals for mounting the lamp in a socket. In this manner, a strong, stable, gas-tight assembly is obtained.

Westinghouse discussed its needs with Driver-Harris. Could the necessary type of thimble stock be obtained, and supplied in strip form, .009" thick, with negligible tolerances?

The answer is found on all Westinghouse sealed beam headlights today. Driver-Harris not only produces an alloy with precisely the properties needed, but advanced D-H rolling techniques meet the exacting dimensional requirements specified.

**SPECIAL ALLOYS FOR SPECIAL PURPOSES** is an important phase of our business. If you have been unable to find the alloy you need, tell us about it. Our 50 years of development and manufacturing experience are at your service.

Makers of world-famous Nichrome\* and over 80 alloys for the electrical, electronic and heat-treating fields

**Driver-Harris Company**

HARRISON, NEW JERSEY

BRANCHES: Chicago, Detroit, Cleveland, Los Angeles, San Francisco

Manufactured and sold in Canada by

The B. GREENING WIRE COMPANY, LTD., Hamilton, Ontario, Canada



## The part played by the metal thimbles in solving the problem is vitally important:

1. It is imperative that the thimbles be composed of a metal alloy with a coefficient of expansion closely approximating that of glass at all temperatures up to the melting point of glass. Any appreciable difference in the rates of expansion would result in the glass being fractured.
2. The thimble stock must be initially and entirely gas-free—to avoid the possibility of bubbles or strains being formed in the glass at the seal.
3. The stock must be held to extremely close tolerances when manufactured—to meet the requirements of meticulous, high-speed presses and dies specially developed to produce the thimbles.

\*T. M. Reg. U. S. Pat. Off.

# VSWR and RF WATTMETER



**SPECIFICATIONS**  
 Frequency Range ..... 50 to over 1000 MCS  
 Impedance ..... 51.5 or 72 ohms  
 Connectors ..... Standard connectors supplied are type N to accept UG-21/U attached to RG-8/U and RG-9/U cable.  
 The instrument is supplied on request, with UHF type connectors to accept 82-1SP attached to RG-8/U and RG-9/U cable.  
 Adapters are available for attaching to 7/8 inch 51.5 ohm coaxial line.

**Power Ranges:**  
 Model MM 565 ..... 0 to 4 watts  
 MM 560 ..... 0 to 12 watts  
 MM 561 ..... 0 to 40 watts  
 MM 562 ..... 0 to 120 watts  
 MM 563 ..... 0 to 400 watts  
 MM 564 ..... 0 to 1200 watts

**Accuracy** ..... Plus or minus 5% of full scale for RF power.  
 Plus or minus 10% for V.S.W.R.  
 Reflection Coefficient . . . Less than 0.01.

## MM 560 SERIES

Provides instant assurance of proper functioning of entire RF portion of transmitter, antenna, and transmission line.

This new MicroMatch reads directly the incident power, reflected power, net power to load, and VSWR of the load. Complete \$97.00

**M. C. JONES ELECTRONICS CO.**  
 BRISTOL, CONNECTICUT

Distributed Outside of Continental U.S.A. by RCA International Div., N. Y., N. Y., U. S. A.

Timely new book surveys

# F-M RADAR SYSTEMS

- Operational principles and techniques
- Circuits
- Apparatus
- Applications

HERE is an overall treatment of frequency radar that covers essential theory, useful techniques and practical uses of this new and important phase of radar technology. Reflecting the findings of a broad research and development program initiated by RCA, this book puts at your fingertips a wealth of timely data designed to broaden your understanding of the principles and possibilities of F-M radar.

Just Published

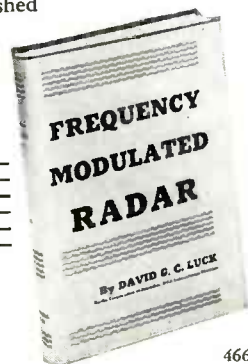

466 pages,  
 6 x 9  
 136 illustrations,  
 \$4.00

By David G. Luck

Research Engineer, RCA, Laboratories Division

The author takes up and develops the general principles of distance and speed determinations by f-m radar. Some of the radio portions of an f-m radar system are then considered, including directive antennas for transmission and reception, oscillators for generating the radio frequency power transmitted, frequency modulators controlling these oscillators, etc. Indicating or control devices suitable for converting f-m data into the useful forms of currents, voltages, shaft positions, frequency spectrum display, etc., are discussed in detail.

- Typical headings**
- Principles of operation
  - Single and Multiple Target Systems
  - Radio Apparatus in F-M Radar Systems
  - Accessory Circuits
  - Motion of Aircraft and Missiles
  - Etc.

The kinematics of simple fire-control problems is developed, and specific f-m radar equipment needed to solve such problems is described. Detailed treatment is given to special principles and circuits typical of f-m radar.



SEE THIS BOOK  
 10 DAYS FREE

McGraw-Hill

McGraw-Hill Book Co., Inc.  
 330 W. 42nd Street  
 New York 18, N. Y.

Send me Luck's FREQUENCY MODULATED RADAR for 10 days' examination on approval. In 10 days I will remit \$4.00, plus a few cents for delivery, or return book postpaid. We pay for delivery if you remit with this coupon; same return privilege.

Name.....  
 Address.....  
 City..... Zone..... State.....  
 Company.....  
 Position..... L-4-50  
 This offer applies to U. S. only

# Best buy!

THE RIGHT MOTOR AT THE RIGHT PRICE  
 EMC AND CYCLOHM FRACTIONAL H.P. MOTORS

Model 500 is a brilliant, seasoned performer used extensively by leading manufacturers of home movie projectors, vending machines, portable tools, radar and electronic equipment, railroad signal lights, laboratory stirrers... wherever a fractional h.p. motor of proved dependability is needed at low cost.

For complete information about EMC model 500 or any of the famous EMC universal, shunt wound, or shaded pole motors and Cyclohm induction motors, write for handy reference literature and specification sheets. All EMC and Cyclohm motors can be furnished with gear units, 12 models, hundreds of ratios.

EMC and Cyclohm fractional h.p. motors are made by fractional h.p. specialists... your guarantee of the right motor at the right price.

**HOWARD**

HOWARD INDUSTRIES, INC. DEPT. EB, RACINE, WISC.

DIVISIONS: EMC—ELECTRIC MOTOR CORP.  
 CYCLOHM—CYCLOHM MOTOR CORP.

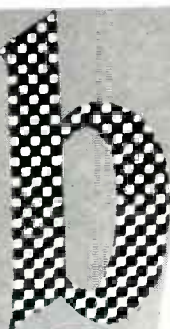

EMC Model 500



Cyclohm Model 2500



EMC—Model 11A



Cyclohm Model 2900



# DU PONT "TEFLON"™\*

**gives maximum efficiency, durability in co-ax connectors  
for Sperry radar set**

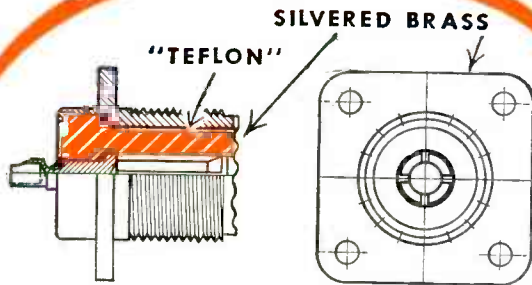

**Coaxial connector in marine radar set—  
attaches flexible cable to a  
rigid housing**



*Connectors made by Industrial Products Division, Danbury-Knudsen, Inc.,  
Danbury, Conn., for Sperry Gyroscope Co., Great Neck, L. I., N. Y.*

**Tough new plastic has  
low dielectric constant, low loss factor,  
excellent heat-resistance**

When a material requirement calls for *low* dielectric constant, *low* loss factor, high heat-resistance, toughness, resiliency—there is *one* material that has all these properties, Du Pont "Teflon" tetrafluoroethylene resin. That's why "Teflon" is superior to all other materials for use in high-frequency connectors. That's why Sperry uses "Teflon" for the insulation in the coaxial connectors for this marine radar set. "Teflon" provides unequalled transmission efficiency plus outstanding durability.

First, "Teflon" has a low dielectric constant (2.0), constant over the entire range of frequencies measured to date. This minimizes step discontinuities that produce reflections of power. In addition, it has a low loss factor (0.0005)—so that little power is lost at the con-

ductor, and the insulation does not heat up in service.

Along with these outstanding electrical properties, "Teflon" has high heat resistance (serves up to 500°F.), eliminates danger of melting the insulation when soldering connections during assembly. It's tough, too, even at temperatures as low as -90°F., won't break or crack if connectors are dropped or banged, has just enough resiliency to give and conform when stressed during installation.

"Teflon" is supplied by Du Pont in standard shapes (rods, tubes, sheets and tape) and molding powders. Or we will recommend molders or fabricators who can supply finished parts of "Teflon." Write today for more information. Our technical staff will be glad to help you. E. I. du Pont de Nemours &

Co. (Inc.), Polychemicals Department, Plastics Sales Offices: 350 Fifth Ave., New York 1, N. Y.; 7 S. Dearborn St., Chicago 3, Ill.; 845 E. 60th St., Los Angeles, California. \*REG. U. S. PAT. OFF.

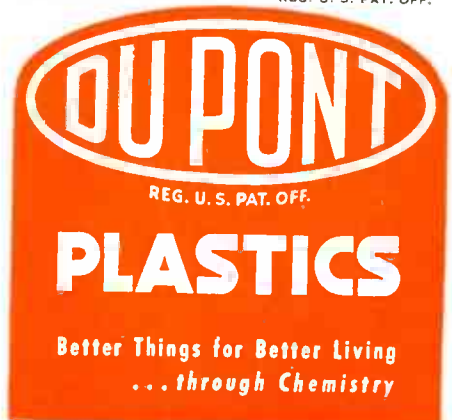

HOW TO *Solve* YOUR CARTRIDGE PROBLEMS *Easily!*

# Check the features!

TO GET **EVERYTHING** YOU WANT

## Specify **E-V** Torque Drive\*

**FREQUENCY RESPONSE** tailored to the requirements of your system. Clean, wide range... roll-off... or cut-off characteristics... to your specifications.

**OUTPUT VOLTAGE** sufficient for full power output without sacrificing desired compliance.

**LATERAL COMPLIANCE** for excellent low frequency tracking at 5-6 grams force.

**VERTICAL COMPLIANCE** to minimize record and tip wear.

**RUMBLE PICK-UP** audibly suppressed without alteration of frequency response characteristics.

**MOISTURE PROTECTION** from high humidity at no extra cost.

**PERFORMANCE DEPENDABILITY** to assure stable response despite temperature change.

**MINIMUM TRACKING FORCE.** Guaranteed tracking throughout the frequency spectrum at only 5-6 grams force.

**STYLII QUALITY.** Long wearing, precision ground tips for high fidelity reproduction and minimum record wear.

**UNIFORMITY IN PRODUCTION.** Precise conformity to laboratory established specifications in quantity production.

**DUAL STYLUS SET-DOWN.** Precise set-down unaltered by stylus replacement.

• Only E-V Torque Drive gives you all these features. Available in single-stylus or dual-stylus types... for 33 $\frac{1}{3}$ , 45 and 78 rpm single-speed or multi-speed record players. E-V engineers and full facilities are at your service.

**E-V Torque Drive cartridges, resonated only by crystal stiffness and low mass driving system, offer wide range, peak-free response. The system can be mechanically tuned to obtain any curve desired.**

**By mechanical step-up, stylus force is multiplied 20 times in the Torque Drive system, producing a high voltage output to compliance ratio.**

**Lateral compliance exceeds unity in E-V cartridges because bearings, bushings and other types of friction are eliminated.**

**The absence of bearing rigidity makes Torque Drive a vertically compliant drive system.**

**Torque Drive cartridges respond only to lateral tip motions and cancel output of vertical motions.**

**All E-V cartridges are moisture inhibited for longer trouble-free life by a special coating of silicone... at the cost of ordinary weather sealing.**

**The response of E-V cartridges depends only on a mechanical drive system which does not employ temperature sensitive pads or damping materials.**

**E-V cartridges track well at 5 grams force because of high lateral compliance and clean, wide range response.**

**Accurate inspection, exacting tests and highest quality materials assure superior performance from each E-V single-tip or dual-tip stylus.**

**The performance of Torque Drive cartridges depends only on a simple harness system and crystal; not on a multitude of minute parts.**

**The E-V in-line, dual tipped stylus admits no set-down variation.** \*Pat. Pend.

# Electro-Voice

PHONO PICKUPS • MICROPHONES

**ELECTRO-VOICE, INC. 401 CARROLL ST., BUCHANAN, MICHIGAN**  
Export: 13 East 40th Street, New York 16, N.Y. U.S.A., Cables: Arlab

TUBES AT WORK

(continued)

tests an aircraft in the design stage.

The flight simulator represents the results of a cooperative project involving more than 50 engineers and nearly three years' work. It was built under the auspices of the U. S. Navy Bureau of Ordnance in the MIT Dynamic Analysis and Control Laboratory.

The flight simulator involves the use of intricate computing machines and a flight table on which actual problems relating to flight stability are worked out. The table is an arrangement of gimbals, delicately suspended so that they can incline freely in any direction and supported on an independent foundation so that there will be no vibration.

The gimbal frame, which is operated by high-speed hydraulic servo-mechanisms, is used to orient the



Gimbal flight table moves in same manner as plane whose flight performance is being checked

automatic control system of a plane or missile just as it would be tested in actual flight. The gimbal frame table rolls, pitches, and goes through all the motions the plane would make in the air under stated conditions.

A problem is worked out on the apparatus by setting electronic computer dials that represent the various important characteristics of the aircraft to be studied—weight, velocity, altitude, wing span and many others. Before the simulator can be used, many of these characteristics are obtained from wind tunnel tests of small models of the proposed aircraft.

Then the question is fed into the





GL-2B22



GL-2C40



GL-2C43



# Lighthouse Tubes

## FOR MICROWAVE APPLICATIONS REQUIRING DEPENDABLE U-H-F PERFORMANCE!

HERE are well-known G-E planar types that take in stride frequencies of thousands of megacycles. *Proved* in military radar—*proved* in commercial u-h-f work—Lighthouse Tubes serve reliably, give long use, as high-level detectors; as pulsed and CW oscillators; and as frequency multipliers and power amplifiers.

If you design or build equipment of the following types, G-E Lighthouse Tubes should have your first consideration:

- Police, taxicab, and other mobile and fixed radio apparatus operating in the 450-460 mc band.
- U-h-f equipment for emergency communications work.

- Aircraft traffic and location control devices of various types.
- Communications multiplex equipment.
- Broadcast relay equipment.
- Telemetry transmitters.
- Microwave test apparatus.

By specifying General Electric Lighthouse Tubes, you further protect your customers in that replacements can be obtained locally. From coast to coast, G-E tube distributors with stocks on hand are equipped to give fast delivery.

Read the facts below about these modern, high-efficiency u-h-f tubes; then ask for prices and complete information. Also . . . G-E tube engineers will be glad to work personally with you in choosing the right types for your circuits. Address *Electronics Department, General Electric Company, Schenectady 5, New York.*

## APPLICATION

### GL-2B22

H-f detector up to 1,500 mc.

### GL-2C40

R-f amplifier, converter, and local oscillator up to 3,370 mc.

### GL-2C43

R-f amplifier and oscillator from 200 mc up to 1,500 mc, and in special plate-pulsed circuits up to 3,370 mc.

## MAXIMUM PLATE RATINGS

Dissipation	----	6.5 w	12 w
Voltage, CW	----	500 v	500 v
Voltage, pulsed	100 v	-----	3,500 v
Voltage, peak inv.	300 v	-----	-----
Current, average	20 ma	25 ma	40 ma

# GENERAL ELECTRIC

180-33

# VULCAN

## ELECTRIC HEATING UNITS

### IMMERSION

FOR HEATING OILS,  
WATER, PARAFFIN,  
CHEMICALS, ETC.  
IN TANKS,  
BOILERS,  
KETTLES,  
URNS.



Various types of  
Bolt-on Flanges and  
Threaded Bushings.

Single and Three-heat, with metal casings. Complete with gaskets, terminal cover, etc.

**VULCAN ELECTRIC COMPANY**  
DANVERS, 10, MASS.

Makers of Vulcan Electric Soldering Tools, Electric Solder Pots, Electric Glue Pots, Electric Branding Irons and Electric Heating Units, including the new Vulcan 900 series, for changing over any hot water heater to electric operation.



## ONLY THE *Potter* DECADE COUNTER offers the simplest, most reliable circuit

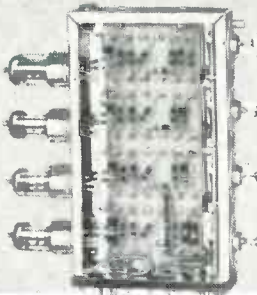

The POTTER 4-tube Decade Counter Circuit has been proven by over five years of actual operation in Government proving grounds, as well as in numerous industrial applications in which a precise count is required for packaging or automatic machine control. The Decades are available either as components to be used in your equipment, or in a packaged POTTER Scaler, Predetermined Counter, or Precision Counter Chronograph. Modified or specially-designed counting, timing and calculating equipment can be supplied for special applications.

For an accurate appraisal of your problem, call or write Dept. 6-P.

- **DIRECT DECIMAL READ-OUT**—four neon glow lamps designated 1—2—4—8, provide a direct indication (0 to 9) of the four trigger stages without a complex resistor matrix.
- **WIDEST BIAS RANGE**—(best test for a counter circuit) insures stable operation.
- **PREDETERMINED COUNTS**—exclusive complementary predetermining makes possible a simple count selector switch and single pulse output at the predetermined count.
- **SMALLEST NUMBER OF COMPONENTS**—uses only four tubes, four glow lamps and the minimum number of parts.
- **DEPENDABLE**—all components are the finest. Examine any of our counters to see the best in electronic construction.

#### APPLICATIONS:

AUTOMATIC PACKAGING      PULSE AND SINE  
PRECISION TIMING              WAVE COUNTING  
FREQUENCY MEASUREMENTS    MEMORY AND  
RADIATION MEASUREMENTS    TRANSLATION  
FREQUENCY DIVIDING  
MACHINE CONTROL

A new low unit price  
of **\$4500** is  
announced as a result  
of wide acceptance  
and quantity production



**POTTER INSTRUMENT CO.**  
INCORPORATED  
136-56 ROOSEVELT AVENUE, FLUSHING, N. Y.

Shown above in actual size is our newest end-on lead sulfide cell—the CE-705—Write, phone or wire for complete information.



**CONTINENTAL  
ELECTRIC CO.**

America's Leader in Quality  
Electronic Tube Manufacture  
GENEVA, ILLINOIS





## That's why **TEMFLEX 105** Plastic Tubing excels in transformer duty

This tubing hits a new high in retained flexibility and elongation. Tested in oils at 90°C. for 60 days, TEMFLEX 105 shows absolutely no change in flexibility . . . no cracking or checking whatever . . . no loss in elongation. Stands up, too, under overload tests.

You won't have to worry about dielectric strength—it actually increases after 60 days in oil at 90°C. The U.L. tests demonstrating this also show that TEMFLEX 105 does not corrode conductors, or increase in thickness after aging. And it's permanently identified with the printing of TEMFLEX 105 along the entire length.

### Be Sure To Send For U.L. Report

Check the complete report and see for yourself how TEMFLEX 105 surpasses any tubing you can buy for transformer service. Generous samples and full data will be sent promptly on request. Write.

\* The only plastic tubing approved by Underwriters' Laboratories for use in high-temperature mineral oil.

*"Look to Irvington  
for Continued Leadership  
in Insulation"*



**IRVINGTON**  
Varnish & Insulator Company  
Irvington 11, New Jersey

FOR ULTRA-PRECISION  
CATHODE RAY TUBES...

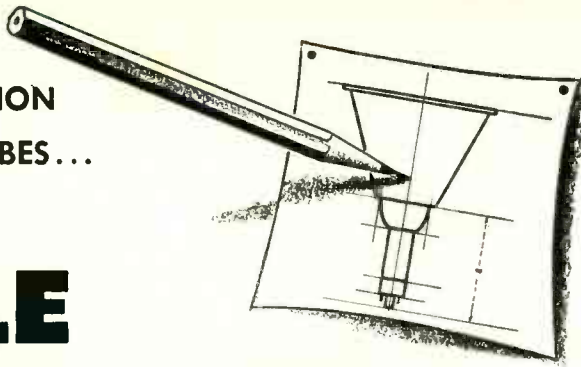

# KAHLE CUSTOM-BUILT MACHINERY

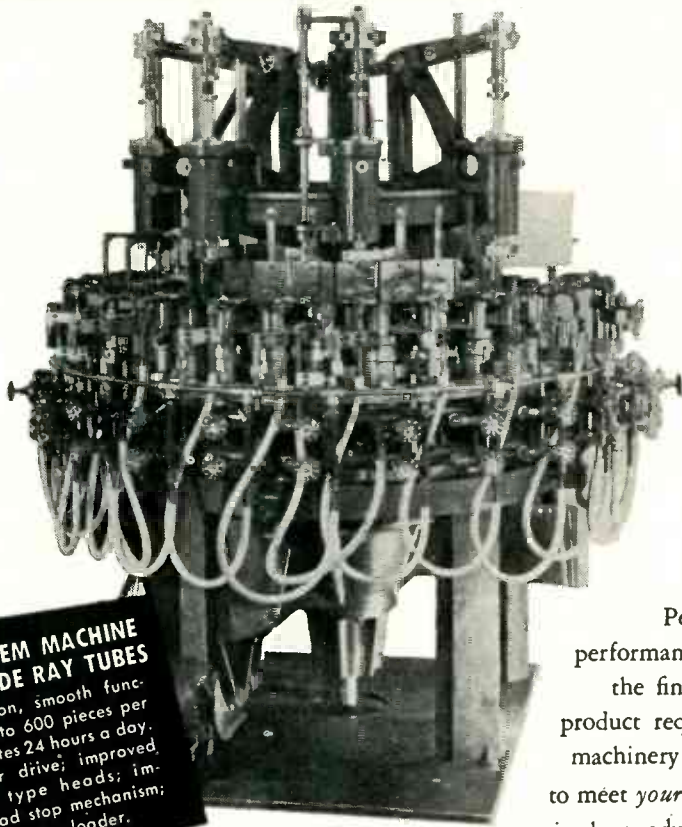

## BUTTON STEM MACHINE FOR CATHODE RAY TUBES

High precision, smooth functioning. Up to 600 pieces per hour; operates 24 hours a day. Dual motor drive; improved clean-out type heads; improved head stop mechanism; automatic stem unloader.

Perfect performance in the finished product requires machinery built to meet *your* need in the production

stage. Kahle's years of experience in meeting the specific requirements of ultra-precision operations with custom-engineering, has helped many outstanding manufacturers of cathode ray tubes operate efficiently and profitably. This Kahle know-how may solve your unusual problem, too. Kahle specialists are available for consultation, without obligation.

Consult Kahle On Any Requirement • Write For Complete New Catalog

Kahle Specializes in Equipment and Methods for the Manufacture of Complete Production Units For:

Cathode Ray Tubes • Subminiature Tubes •  
Electronic Tubes • Fluorescent Lamps • Neon Tubes  
• Photocells • X-Ray Tubes • Glass Products

# Kahle

ENGINEERING COMPANY

1309 SEVENTH STREET

• NORTH BERGEN, NEW JERSEY

TUBES AT WORK

(continued)

simulator by applying appropriate electrical signals through a control board. The answer is returned on a chart on a recording apparatus in a matter of seconds.

## British Television Relay

BY JOHN H. JUPE  
Enfield, Middlesex  
England

THE RADIO RELAY SYSTEM for television recently demonstrated in Britain comprises a chain of uhf radio transmitters and receivers working on frequencies of about 900 mc to link London and Birmingham (about 120 miles) for television programs in a continuous public service. The equipment, which was designed, manufactured and installed by the General Electric Co. Ltd. of England for the United Kingdom Post Office, will ultimately enable programs to be sent in both directions simultaneously but initially only one-way traffic will be possible.

There are two terminal stations and four repeaters, at present working on frequencies of 870 and 980 mc, and a station which receives on one frequency will transmit on the other so that the receiving antenna cannot pick up energy from the local transmitter. When the two-way link is brought into use there will be two additional frequencies of 917 and 937 mc.

Frequency modulation is used in



Antennas and towers at the London terminal of the system



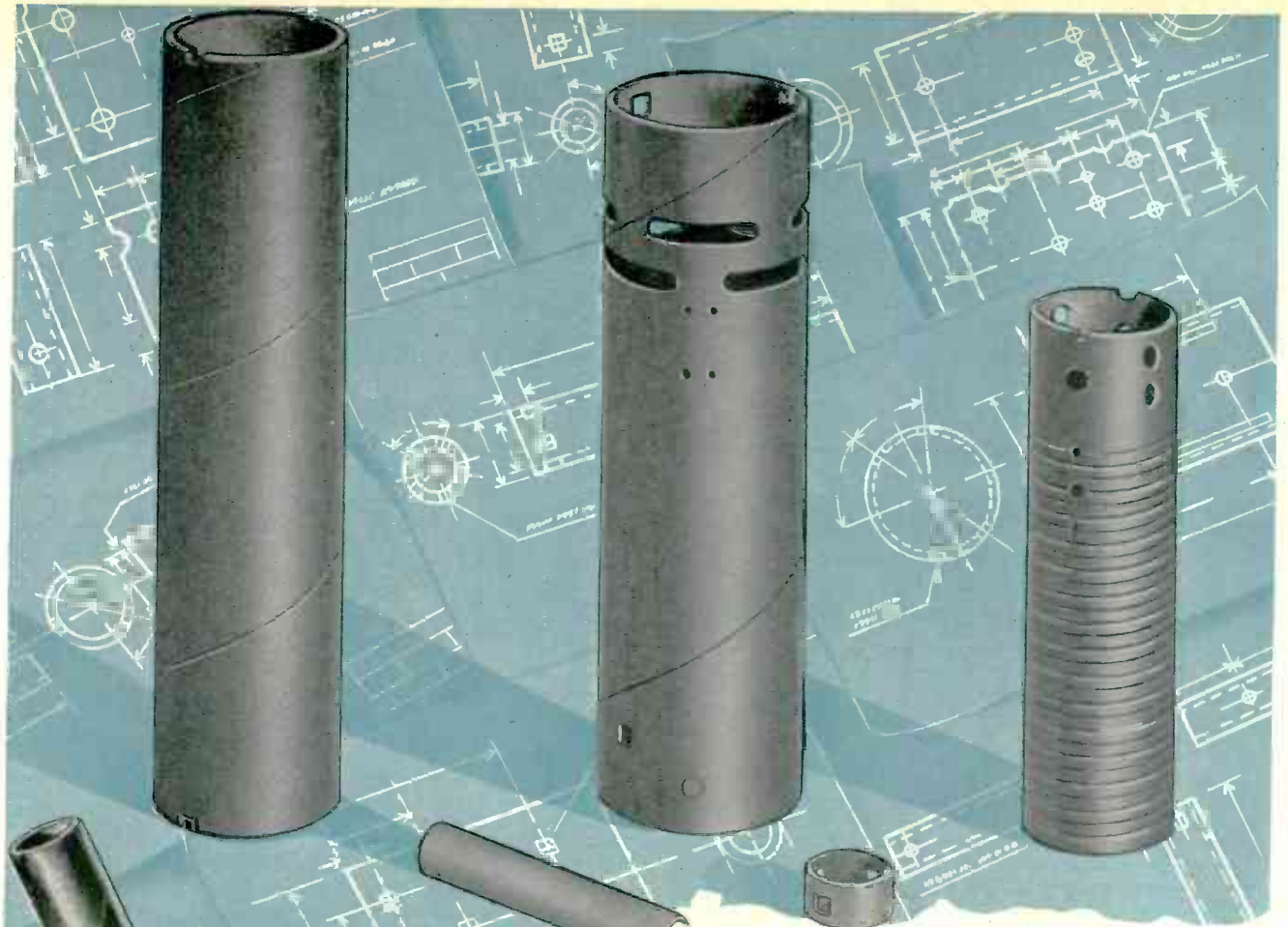

**QUALITY... Plus ADAPTABILITY**

# CLEVELAND

**COSMALITE\* AND CLEVELITE\* SPIRALLY LAMINATED PAPER BASE PHENOLIC TUBES**

Cosmalite is known for its many years of high quality performance. Clevelite is the new improved tubing designed to meet more exacting specifications.

"Cleveland" has an enviable record of service and dependability. Your orders receive prompt attention. Deliveries are made in time for your production schedules.

For the best . . . "Call Cleveland." Samples on request.

Proven Performance  
in the Radio  
and Television fields

Excellent for  
Motors, Relays,  
Transmitters,  
Fans, Controls,  
Switches, Bobbins  
and many others.

\*Trade Mark

*The* **CLEVELAND CONTAINER Co.**  
6201 BARBERTON AVE. CLEVELAND 2, OHIO

PLANTS AND SALES OFFICES at Plymouth, Wisc., Chicago, Detroit, Ogdensburg, N.Y., Jamesburg, N.J.  
ABRASIVE DIVISION at Cleveland, Ohio  
CANADIAN PLANT: The Cleveland Container, Canada, Ltd., Brescott, Ontario

**REPRESENTATIVES**

CANADA	WM. T. BARRON, EIGHTH LINE, RR #1, OAKVILLE, ONTARIO
METROPOLITAN	R. T. MURRAY, 614 CENTRAL AVE., EAST ORANGE, N.J.
NEW YORK	E. P. PACK AND ASSOCIATES, 968 FARMINGTON AVE.
NEW ENGLAND	WEST HARTFORD, CONN.



# STABILINE VOLTAGE REGULATORS

## *Guaranteed*

BY

**THE SUPERIOR ELECTRIC CO.**

The Superior Electric Company packs into its voltage control equipment a wealth of research, design and production experience. Each unit is guaranteed to deliver — over normal periods of operation and life-expectancy — all the performance characteristics stated in Superior Electric advertising.

### WHY THE GUARANTEE

Every STABILINE Automatic Voltage Regulator shipped from The Superior Electric Company has been inspected and tested to the most rigid mechanical and electrical specifications. It is your assurance that they will perform as advertised.

### THESE ARE THE SUPERIOR ELECTRIC VOLTAGE REGULATORS THE VARICELL (above left)

The latest Superior Electric development in voltage control equipment. Delivers DC voltage, variable from 0 to 30 volts, from an AC source. Output is stabilized — held to set values regardless of line variations. Output is regulated — unit automatically compensates for load fluctuations. Operates from any 95-135 volt, 60 cycle, single phase AC line. Stabilization and regulation are  $\pm 0.25\%$  for output settings between 6 and 30 volts. R.M.S. ripple voltage does not exceed  $\pm 0.1$  volts.

### STABILINE TYPE IE (above center)

Completely electronic and instantaneous in operation. No moving parts. Maintains output voltage to within  $\pm 0.1$  volts of nominal for line voltage variations; to within  $\pm 0.15$  volts for any load current change — or for any load power factor change from 0.5 lagging to 0.9 leading. Waveform distortion *never* exceeds 3%. Available in a wide range of capacities.

### STABILINE TYPE EM (above right)

Maintains constant voltage on heavily loaded lines. Features zero waveform distortion; complete insensitivity to magnitude and power factor of load; no effect on power factor; no critical adjustments; high efficiency; adjustable output voltage. Available for a wide range of applications in 115, 208, 230, 440 volt, single and three phase ratings; capacities to 100 KVA.

### GET COMPLETE INFORMATION BEFORE YOU BUY

The Superior Electric Company welcomes inquiries regarding any of its voltage control equipment. Your questions will receive prompt and complete answers. We're always ready to consult with you on voltage regulation problems — at no obligation to you.

WRITE 404 MEADOW STREET, BRISTOL, CONNECTICUT

**THE SUPERIOR ELECTRIC CO.**  
BRISTOL, CONNECTICUT



POWERSTAT VARIABLE TRANSFORMERS • VOLTBOX A-C POWER SUPPLIES • STABILINE VOLTAGE REGULATORS

the system and modulation of the carrier is achieved at a terminal station in two steps. The incoming video signal from the studios is used to frequency-modulate an oscillator between 32.5 and 35.5 mc, and the modulated output is amplified and fed to the final stage of the transmitter, together with the output of a 900-mc generating chain. In the transmitter output stage appear frequencies which differ from that of the r-f chain by plus or minus the modulated oscillator frequency, and both of these frequencies (above and below carrier) are also frequency-modulated by the video signal to the same degree as the original 34-mc oscillation. Filters select one of these frequency-modulated carriers to be the signal that is transmitted.

### Repeater Circuits

At a repeater station the received signal is heterodyned by a local oscillator to give a difference frequency of 34 mc and the resultant intermediate frequency is amplified and the transmission process repeated. The fact that the carrier signal is not demodulated to video frequency until the end of the link is reached is very important since it obviates the difficulties in connection with amplifier design and operation at low video frequencies.

Because a repeater transmitter and receiver work at different frequencies the receiver local oscillator frequency cannot be the same as that of the oscillator in the transmitter master oscillator. At a re-

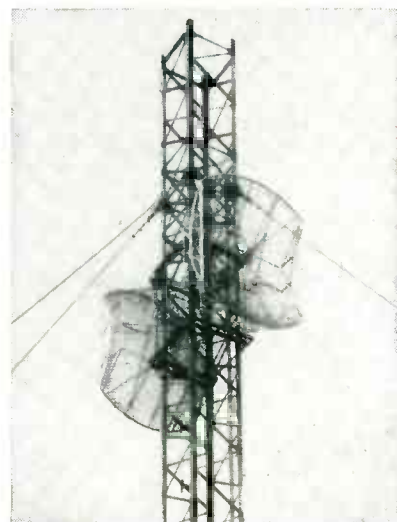

Typical antenna array on a temporary mast



# If it's a problem calling for **PRECISION POTENTIOMETERS**

## Bring it to Helipot

For many years The HELIPOT Corporation has been a leader in the development of advanced types of potentiometers. It pioneered the *helical* potentiometer—now so widely used in computer circuits, radar equipment, aviation devices and other military and industrial applications. It pioneered the *DUODIAL*—the turns-indicating dial that greatly simplifies the control of multiple-turn potentiometers and other similar devices. And it has also pioneered in the development of many other unique potentiometric advancements where highest skill coupled with ability to mass-produce to close tolerances have been imperative.

In order to meet rigid government specifications on these developments—and at the same time produce them economically—HELIPOT® has perfected unique manufacturing facilities, including high speed machines capable of winding extreme lengths of resistance elements employing wire even less than .001" diameter. These winding machines are further supplemented by special testing facilities and potentiometer "know-how" unsurpassed in the industry.

So if you have a problem requiring *precision potentiometers* your best bet is to bring it to The HELIPOT Corporation. A call or letter outlining your problem will receive immediate attention!

\*Trade Marks Registered

In this panel are illustrated standard models of HELIPOT multi-turn and single-turn precision potentiometers—available in a wide range of resistances and accuracies to fulfill the needs of nearly any potentiometer application. The Beckman DUODIAL is furnished in two designs and four turns-ratios, to add to the usefulness of the HELIPOT by permitting easy and rapid reading or adjustment.

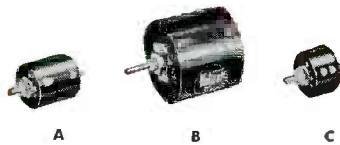

#### MODELS A, B, & C HELIPOTS

A—10 turns, 46" coil, 1-13/16" dia., 5 watts—resistances from 10 to 300,000 ohms.  
 B—15 turns, 140" coil, 3-5/16" dia., 10 watts—resistances from 50 to 500,000 ohms.  
 C—3 turns, 13-1/2" coil, 1-13/16" dia., 3 watts—resistances from 5 to 50,000 ohms.

— Ask for Bulletin 104 —



#### MODELS D AND E HELIPOTS

Provide extreme accuracy of control and adjustment, with 9,000 and 14,400 degrees of shaft rotation.

D—25 turns, 234" coil, 3-5/16" dia., 15 watts—resistances from 100 to 750,000 ohms.  
 E—40 turns, 373" coil, 3-5/16" dia., 20 watts—resistances from 200 ohms to one megohm.

— Ask for Bulletin 104 —



#### MODELS F AND G PRECISION SINGLE-TURN POTENTIOMETERS

Feature both continuous and limited mechanical rotation, with maximum effective electrical rotation. Versatility of designs permit a wide variety of special features.  
 F—3-5/16" dia., 5 watts, electrical rotation 359°—resistances 10 to 100,000 ohms.  
 G—1-5/16" dia., 2 watts, electrical rotation 356°—resistances 5 to 20,000 ohms.

— Ask for Bulletin 105 —

#### LABORATORY MODEL HELIPOT

The ideal resistance unit for use in laboratory and experimental applications. Also helpful in calibrating and checking test equipment. Combines high accuracy and a wide range of 10-turn HELIPOT with precision adjustability of DUODIAL. Available in eight stock resistance values from 100 to 100,000 ohms, and other values on special order.

— Ask for Bulletin 102 —



#### MODELS R AND W DUODIALS

Each model available in standard turns-ratios of 10, 15, 25 and 40 to 1. Inner scale indicates angular position of HELIPOT sliding contact, and outer scale the helical turn on which it is located. Can be driven from knob or shaft end.

R—2" diameter, exclusive of index.

W—4-3/4" diameter, exclusive of index. Features finger hole in knob to speed rotation.

— Ask for Bulletins 104 and 114 —

The versatility of the potentiometer designs illustrated above permit a wide variety of modifications and features, including double shaft extensions, ganged assemblies, the addition of a multiplicity of taps, variation of both electrical and mechanical rotation, special shafts and mounting bushings, high and low temperature operation, and close tolerances on both resistance and linearity. Examples of potentiometers modified for unusual applications are pictured at right.



#### 3-GANGED MODEL A HELIPOT AND DOUBLE SHAFT MODEL C HELIPOT

All HELIPOTS, and the Model F Potentiometer, can be furnished with shaft extensions and mounting bushings at each end to facilitate coupling to other equipment. The Model F, and the A, B, and C HELIPOTS are available in multiple assemblies, ganged at the factory on common shafts, for the control of associated circuits.



#### MULTITAPPED MODEL B HELIPOT AND 4-GANGED TAPPED MODEL F

This Model B HELIPOT contains 28 taps, placed as required at specified points on coil. The Four-Gang Model F Potentiometer contains 10 taps on each section. Such taps permit use of padding resistors to create desired non-linear potentiometer functions, with advantage of flexibility, in that curves can be altered as required.

THE **Helipot** CORPORATION, SOUTH PASADENA 2, CALIFORNIA

## TWO New electronic products

with New advantages for you!

### STUPAKOFF

# STUPACITORS

## Trimmer and Stand-off Ceramic Capacitors

### TRIMMERS

The ideal Trimmers for standard and temperature-compensating capacities, starting at 0.5 mmf.

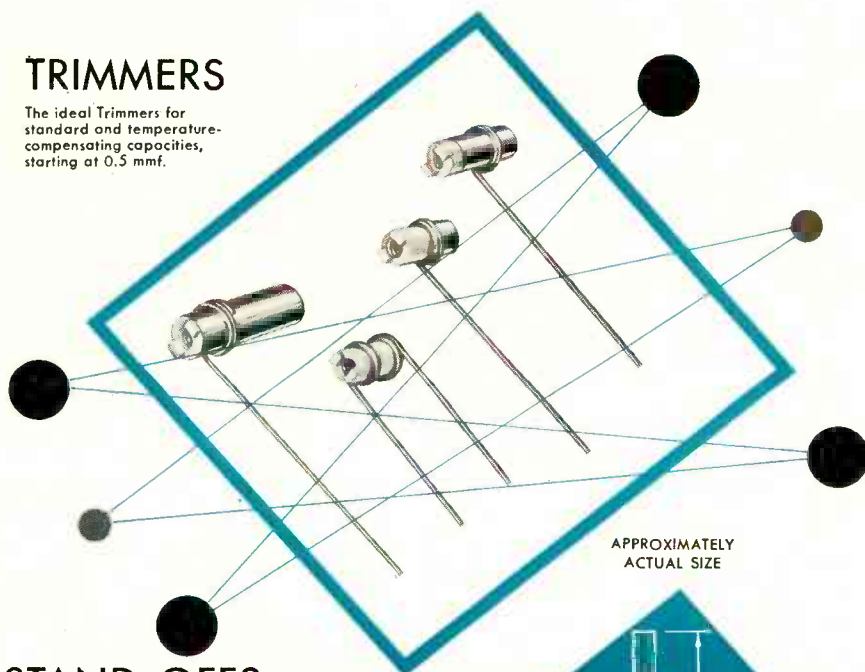

APPROXIMATELY  
ACTUAL SIZE

### STAND-OFFS

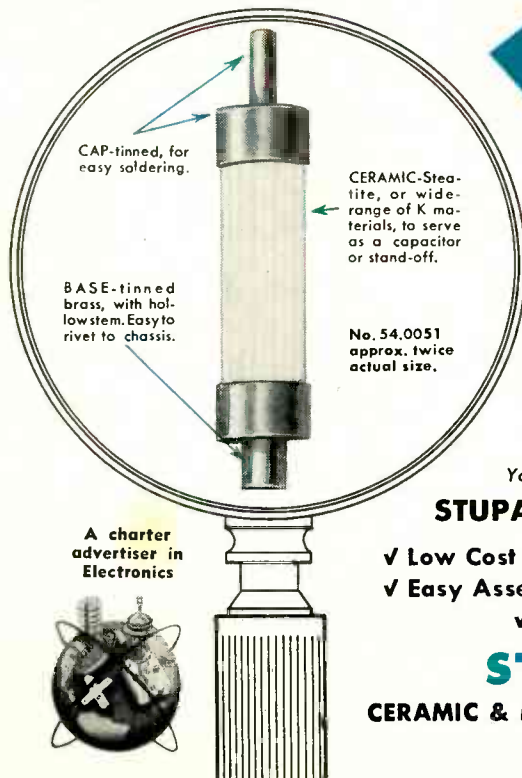

A charter advertiser in Electronics

No. 54.0051  
approx. twice  
actual size.

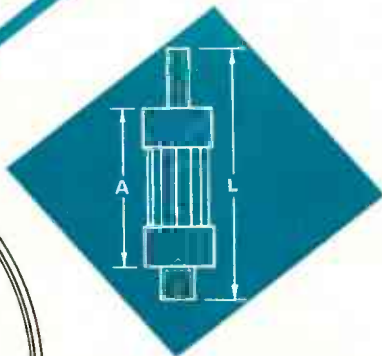

NUMBER	A	L	CAP. - mmf.
54.0048	1/2	51/64	0.2
54.0049	5/16	39/64	0.4
54.0051	3/4	1 - 3/64	0.1
54.0058	5/16	39/64	50.0
54.0059	5/16	39/64	100.0

Serves as a Capacitor  
as Well as a Stand-off

You get these advantages with

### STUPACITOR STAND-OFFS

- ✓ Low Cost
- ✓ Neat Appearance
- ✓ Easy Assembly
- ✓ Fewer Parts Needed
- ✓ Compact Assembly

## STUPAKOFF

CERAMIC & MANUFACTURING COMPANY

Latrobe, Pennsylvania

peater station, the local oscillator frequency is obtained from part of the transmitter master oscillator output by heterodyning it with the output of a crystal-controlled oscillator whose frequency is equal to the difference between the transmitted and received frequencies.

This arrangement of the local and master oscillator frequencies being each above (or below) the received and transmitted frequencies respectively results in the transmitted frequency being independent of the drift of the station master oscillator and is affected only by the extremely small drift of the crystal-controlled oscillator. Since only two frequencies are used for a channel the shift frequency is the same at all repeater stations and is alternately added to or subtracted from the station master oscillator frequency.

The gain of each repeater is 70 db with a transmitter power of 10 watts.

The aerial system contains a coaxial-fed dipole with parasitic reflectors and a 14-foot paraboloid. The horizontal aperture of the paraboloids is cut away to 10 feet with very little loss of gain because horizontal polarization is used throughout. The gain of the aerial is 27.5 db relative to a half-wave dipole.

### Telemetering

The link is entirely automatic in operation and all repeater stations are capable of working almost indefinitely without attention. Fault monitoring is provided on the units of the equipment and the fault indications are sent to the appropriate control point (London or Birmingham) over a four-wire voice-frequency signalling system. This system also carries the control signals to and from the radio stations.

Fault indications at a control point include information regarding each radio station as to whether it is working, which channel equipment and power unit has been selected and whether a fault has occurred and automatic changeover taken place. Faults are also indicated as major or minor. Indication will also be given as to whether the station power line is on and, in the case of repeater stations, whether



**DPI announces  
the new MCF-60  
High Vacuum Pump  
for automatic tube  
exhaust machines**

**...and answers  
these questions**



**1. WHY TRY TO GET THE HIGHEST  
VACUUM IN TUBES YOU MAKE?**

Because it expands markets for you and the entire industry. It's basic that the higher the vacuum in a tube, the longer it gives satisfactory service and the more confidence ultimate users feel in the equipment it serves.

**2. WHY PUMP DOWN FAR IF YOU  
FINISH OFF WITH A GETTER?**

Ultimate vacuum attained by a getter depends on how much gas you leave for it to clean up. If you overload your getter, it emits gas back into the tube during service. If you use a lot of getter, you spread an appreciable coating over the envelope and components—with an adverse effect on operating characteristics.

**3. HOW FAST AND HOW FAR DOES THE  
MCF-60 TAKE PRESSURE DOWN?**

The new MCF-60 3-Stage Fractionating Oil Diffusion Pump handles 60 liters per second in the range from  $10^{-5}$  to  $10^{-3}$  mm. Hg and reaches an ultimate vacuum of  $5 \times 10^{-7}$  mm. Hg. Its powerful vapor jets can operate against a forepressure of 0.2 mm. Hg or more. The jet assembly can easily be removed for cleaning.

**4. HOW DO OPERATING COSTS  
COMPARE?**

Even though the MCF-60 pumps many times faster than a mercury diffusion pump and attains 10 to 100 times higher vacuum, *it's a lot less expensive to operate* because it requires no handling of liquid air. We'll be glad to supply full details.

**DPI**

HIGH VACUUM RESEARCH  
AND ENGINEERING

VACUUM EQUIPMENT DEPARTMENT  
**DISTILLATION PRODUCTS industries**

727 RIDGE ROAD WEST, ROCHESTER 3, N. Y.  
Division of Eastman Kodak Company

*Distillers of Oil-Soluble Vitamins and Other Concentrates for  
Science and Industry; Manufacturers of High Vacuum Equipment.*

**NOW... the best lines for industry and research are all under ONE roof!**

**MILO**

**ONE call  
gets  
them  
All!**

**SIMPSON ELECTRIC  
STANDARD TRANSFORMER • BURGESS  
CORNELL-DUBILIER • A. B. DUMONT • ERIE  
AMPHENOL • HAMMARLUND • NATIONAL COMPANY  
CINCH-JONES • JAMES MILLEN • SYLVANIA • BUD  
HICKOK • IRC • OHMITE • ATR • UTC • etc.**

Only Milo now answers your call for the specialized products of every outstanding manufacturer of electronic parts, tubes and equipment—for all your production, research and industrial needs.

### STREAMLINED ONE-SOURCE PURCHASING SAVES YOU MONEY, TIME AND EFFORT!

Only Milo gives you these exclusive buying advantages:

- ★ **QUICK, EASY, SIMPLIFIED PURCHASING** — One constant, dependable source for all your procurement. No wasteful hunting around. No hazardous, costly guessing.
- ★ **COMPLETE NEWEST STOCKS** — Up to specified quantities, you get the identical price the factories would give you.
- ★ **SAME-DAY SHIPMENT** — Assures you of fast, on-time delivery — prevents costly delays.
- ★ **TECHNICAL KNOW-HOW AND KNOW-WHAT** — The up-to-the-minute, right, fast answers you need, by men with decades of experience in industrial electronics requirements.
- ★ **PERSONAL ATTENTION AND ADVICE** — Whether your order is large or small, Milo's large staff of Industrial Salesmen is ready to help you with the latest information and personal consultation, at your office if you so desire.

### The Newest Products of the Best Manufacturers are always at MILO

Here are just a handful of the latest products of major interest to you now available from Milo's great warehouse of complete stocks:

**ASTRON\***—New hermetically sealed midget metallized paper capacitors.

**CONDENSER PRODUCTS\***—Plasticon silicon-filled glassmikes.

**CONTINENTAL CARBON\***—Nobeloy precision resistors, ideal for meter work and other industrial applications.

**ALLEN B. DUMONT LABORATORIES**—New oscilloscopes, superseding the famous 208B. Type 304, \$308.00 each. Type 304H, \$328.00 each.

**HICKOK\***—New types 292X microvolt generator, 195B oscillograph, and 465 television kilovoltmeter—all designed specifically for industrial application.

**IRC\***—New type DCH and DCF precision resistors. BTS, BTA, BT2 and BW resistors, in all tolerances and values. New CLA and CL-1 insulated chokes, readily identified with RMA color coding in microhenries.

**SYLVANIA\***—All types of germanium crystals, new glow modulators, gas pressure tubes. TR and ATR tubes, strobotrons, thyratrons, flash tubes.

**ALLEN BRADLEY\***—Potentiometers, and EB, GB, HB resistors in all tolerances and values.

\*Prices and literature on these products available upon written request on your letterhead.

To get it right, to get it fast, to get it at the factory price—Call Milo's INDUSTRIAL SALES DIVISION today. Ask for Mr. Lee. Or write on your letterhead for free latest Catalog E.

**MILO**

PHONE

**BEekman 3-2980**

**Radio & Electronics Corp.**

200 Greenwich Street, New York 7, N. Y.

Cable Address: MILOELECTRO

The ONE source for ALL your electronic needs



Receivers used in the British television relay system

the standby generator is working.

A fault on the supervisory system will also be shown at the control point, where it will be possible to switch the equipment at all stations, on and off and to make a changeover between working and standby units. These operations may be performed for all stations simultaneously or for each station individually. If the supervisory system breaks down the stations will continue to work with preset time switching.

From a circuit point of view the link is built (in its radio frequency stages) around Osram disc-seal triodes type DET.24 and ACT.25, which are used in coaxial line circuits.

#### Tube Layout

The transmitter consists of a master oscillator (type DET. 24), a first r-f amplifier (type DET. 24), a second r-f amplifier (type ACT. 25) and a modulated (ACT. 25) or frequency-changer stage.

In addition there is a frequency-shifter stage (type DET.24) for the derivation of local oscillator power, together with its associated 20-mc crystal-controlled shift-frequency generator. The transmitter is designed for normal operation at full output with a drive of 4 volts, (peak-to-peak) of intermediate frequency signal. This i-f signal is amplified to a level sufficiently high to modulate the last stage of the transmitter in a wide-band ampli-



# Trifles . . . that taboo Troubles—

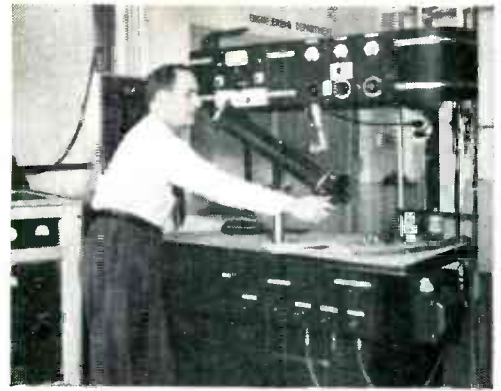

**Electronic Engineering Laboratory** equipment for testing emission characteristics of nickel cathode materials.

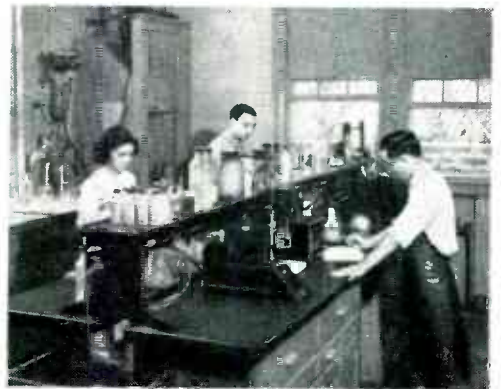

**The Chemical Laboratory** where nickel and nickel alloys are carefully analyzed as a part of Superior quality control.



● They're trifling things—these tiny tubes! But used as cathodes, anodes, and grids, in electronic tubes, they have to give superior performance. You can count on Superior. Electronic research and development, faster production and metallurgical control combine with close inspection, uniformity, and dependability to make Superior products the best obtainable.

Superior from the beginning pioneered in the perfection of these

vital components. Its facilities and equipment can produce the type of dependable products you have a right to expect. It's simply a matter of technology in tubing.

You may already be working with Superior. Nearly all electronic manufacturers are. If small tubing can help you, Superior can. Why not find out? Superior Tube Company, 2500 Germantown Avenue, Norristown, Pennsylvania.

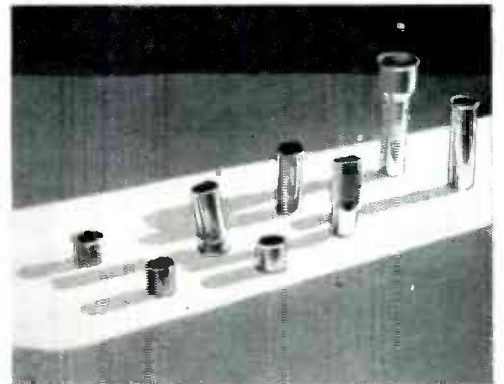

**Tubular parts** made to the exacting requirements of the Electronics Industry. Chemical and metallurgical engineering controls together with a penetrating production system help make Superior's electronic parts outstanding.

## Which Is The Better For Your Product . . .

**SEAMLESS . . . ?** The finest tubes that can be made. In all O.D.'s from  $\frac{3}{8}$ " and lower. Excellent for forming, bending, machining, etc. carbon, alloy, stainless, non-ferrous and glass sealing alloys.

**Or LOCKSEAM\* . . . ?** Produced directly from nickel alloy strip stock by our patented machines. Available in a wide range of nickel alloys. Round, rectangular, oval or square, cut to specified lengths, beaded or flanged.

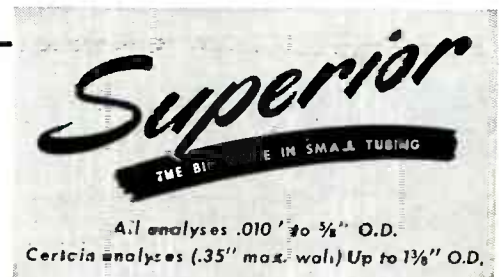

\*Mfd. under U.S. Pats. — Superior Tube Company • Electronic Products for export through Driver-Harris Company, Harrison, New Jersey • Harrison 6-4800

# Ask for ALLEN HEADS by name

There are 1,588 standard items in the Allen line, including a type, size, thread and point to meet every normal requirement in . . .

COMPARE THE PRESSUR-FORMD HEADS FOR STRENGTH

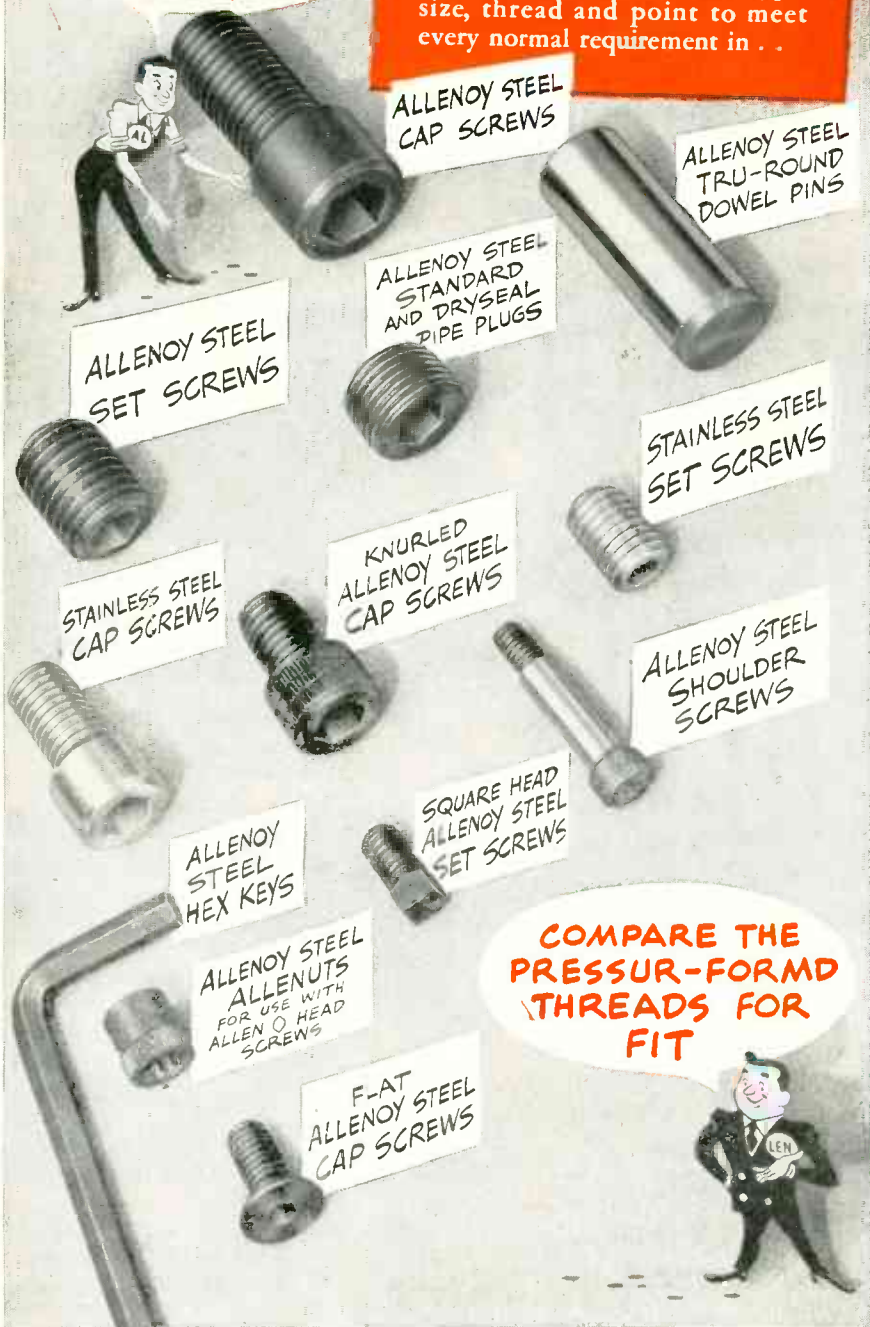

COMPARE THE PRESSUR-FORMD THREADS FOR FIT

**SOLD ONLY THROUGH LEADING DISTRIBUTORS.** Write the factory direct for technical information, or consult our engineers on any problem involving special sizes, shapes or materials.



**ALLEN** ALLEN HEAD  
 MANUFACTURING COMPANY  
 Hartford 2, Connecticut, U. S. A.  
 NEW YORK CLEVELAND DETROIT CHICAGO LOS ANGELES

FOR 40 YEARS THE BUY-WORD FOR SOCKET SCREWS

fier using Osram A.1820 and KT.67 tubes.

The receiver uses a silicon crystal as a frequency changer, local oscillator power being fed from the transmitter via a filter consisting of two cavity resonators, which remove unwanted components generated in the frequency shifter. The receiver i-f amplifier uses two stages with a pair of Osram E.1714 low-noise triodes, followed by three age stages using a pair of Osram Z.77 pentodes, and a further two stages each using two Z. 77 tubes. The output stage is a cathode-follower employing two Osram type A.1820 tubes.

The radio-frequency filters used in the system are of two main types, band-pass filters comprising pairs of coupled resonant cavities and band-elimination filters based on the properties of multiple resonant lengths of transmission lines. Similar resonant-line principles are used in the contactless r-f switches used for switching from working to standby transmitters and receivers.

## SHOP SHORTCUTS

BEGINNING a new service to readers, particularly those involved in engineering production lines and practical laboratory techniques. Contributions are cordially invited. The Editors.

CABLED leads attached to chassis mounted on a transmitter cabinet door bent and broke readily when the door was opened and closed. Substitution of spaghetti for the cabling cord provides better distribution of strain along wires and eliminates broken leads.

*Westinghouse Electric Corp.  
 Baltimore, Maryland*

CALIBRATOR on a coil-winding machine continued to indicate turns after wire snapped accidentally. Because each coil took about 17,000 turns, it was impossible to gage the number of turns wound before the break. A mercury switch is now





Photo by Earl Leaf from Guillemette

## out deep... *it's different*

Too bad all the ocean isn't this clear. There'd be no need for complicated under-water detection equipment, no need for constant research and development of depth-finding instruments and sonar equipment such as Edo engineers are working on now.

But as long as the ocean depths can hide their secrets, we'll need better and better eyes and ears with which to see and hear — electronically — what's below. Much is being pioneered along these lines at Edo.

Already Edo equipment, designed and manufactured for the U.S. Navy, makes possible new accuracy in under-water detection techniques.

### WHO IS EDO?

Twenty five years of research, development and manufacturing experience are behind Edo's work in the electronic field. Founded in 1925, the company first built seaplane floats, later expanded to the design and manufacture of marine aircraft, and built various aircraft components in great quantity during the war. Now to this intimate knowledge of aviation, has been combined top engineering and manufacturing talent in the field of electronics for the design and production of various types of under-water detection equipment.

For a complete picture of Edo's first quarter of a century send for your copy of "Edo's 25th Anniversary" brochure by writing to the Edo Corporation, Dept. ES-1, College Point, N. Y.



EDO CORPORATION • COLLEGE POINT, N. Y.



mounted on an arm with a small pulley that rides the wire. If the wire snaps, the switch shuts off the machine and stops the count. Wire can be spliced and operation resumed with an accurate record of number of turns wound. Cost of coils has been virtually cut in half and suggestion won \$1,500 for Hazel Williams, a worker in the plant.

*Stromberg-Carlson Company  
Rochester, New York*

IN ASSEMBLY of small transformers, laminations were held by a steel strap whose ends were soldered together. Heat developed in unit during impregnation melted solder and laminations sprung apart. Resistance welding is now done on strap from one side with a double-electrode jig.

*Westinghouse Electric Corp.  
East Pittsburgh, Pa.*

A CABLE comprising 24 wires handles 70 percent of the wiring in Olympic television receivers. Installed in each receiver on a production line turning out 650 sets a day, the cable has been found to save time at testing, trouble-shooting and repair positions. Push-top binding posts are used at this plant to hold the ends of wires in position while cable is being formed.

*Olympic Radio & Television Co.  
Long Island City, N. Y.*

**ELECTRONS**  
NEWARK, N. J.  
**C6J/A**  
MANUFACTURED UNDER ONE OF THE FOLLOWING U. S. PATENTS  
1,728,840 1,825,059  
1,874,877 1,826,692  
1,771,152 1,825,174  
1,771,153 1,825,144  
1,874,836 1,825,145  
1,874,833 1,825,092  
1,874,834 1,825,791  
LIGHT FILAMENT BEGINS  
APPLYING D-C LOAD

**ELECTRONS INCORPORATED**  
127 SUSSEX AVENUE  
NEWARK, N. J.

*The tough amphoteric oxide coating of the C6J/A  
Xenon thyratron is your safeguard against cathode  
deterioration under severe ion bombardment.*





# S.S. WHITE MOLDED RESISTANCE UNITS

Successfully endure in ANY climate

Planes of the Pan American Airways, Inc. carry Radio Equipment in which S. S. White resistors operate in the most gratifying manner.

The S. S. WHITE Dental Mfg. Co. INDUSTRIAL DIVISION  
Knickerbocker Bldg., New York, N. Y.

## It was true 20 years ago..

### S.S. WHITE FLEXIBLE SHAFTS

were "old-timers" when the electronics industry was in its infancy. In the last 20 years millions of feet of S.S. White shafting of both the power drive and remote control types have been used in electronic equipment, including AM, FM and TV receiving and transmitting sets, diathermy machines and laboratory equipment.

#### BULLETIN 4501

contains basic information on how to select and apply flexible shafts. Write for a complimentary copy.

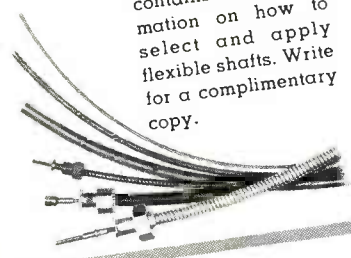

### IT'S JUST AS TRUE TODAY

In this ad, which appeared in a 1930 issue of *Electronics*, we stated that S.S. White Resistors "successfully endure in ANY climate." It was true then, and the experience of the intervening 20 years has served to establish this fact more firmly.

S.S. White Resistors come in two classifications. Type 65X Resistors are rated at 1 watt and have a range from 1000 ohms to 10,000,000 megohms. Type 80X Resistors are rated at 4 watts and have a range of from 100 to 100,000 megohms.

BULLETIN 4906 has details, including construction, characteristics, dimensions, etc. Send for a copy.



# S.S. WHITE INDUSTRIAL DIVISION

THE S. S. WHITE DENTAL MFG. CO. DEPT. E 10 EAST 40th ST., NEW YORK 16, N. Y.



FLEXIBLE SHAFTS AND ACCESSORIES  
MOLDED PLASTICS PRODUCTS—MOLDED RESISTORS

One of America's AAAA Industrial Enterprises

# Atom pile by-products "fly" to help medical research

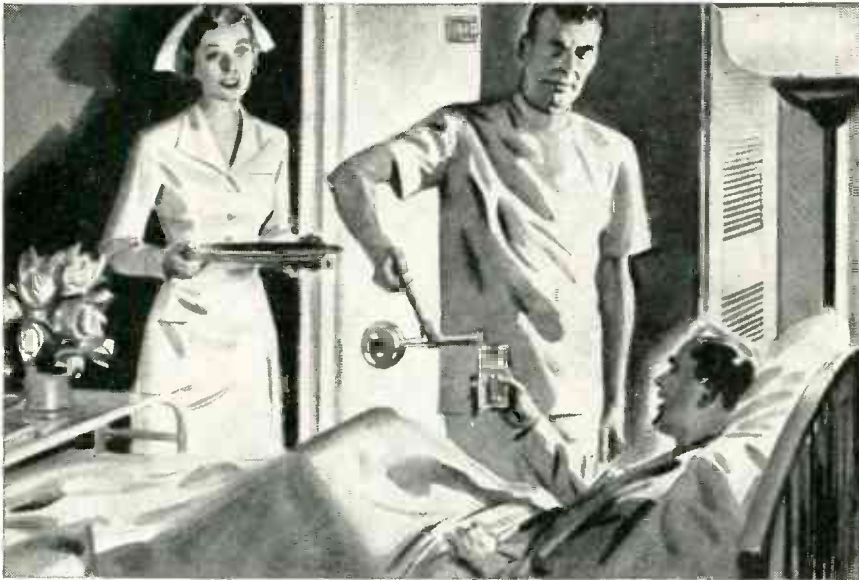

**Radioisotopes** were needed by a Boston hospital for patient treatment. Lead-shielded box of radioactive iodine (weight, 35 lbs.) picked up by Air Express in Knoxville, Tenn., at 11 A.M., delivered 7:15 P.M. Charge, \$8.60. Hospitals, like all business, use Air Express regularly to get supplies from anywhere in hours.



It's easier and more convenient to use the *world's fastest* shipping service. When shipments are ready, just phone for pick-up. Special door-to-door service included in the low rates.



**Shipments keep moving.** Air Express goes on every Scheduled Airline flight. Frequent schedules. Use dependable, experienced Air Express—keep your business rolling at a profitable clip.

## Only Air Express gives you all these advantages

**World's fastest shipping service.**

**Special door-to-door service** at no extra cost.

**One-carrier responsibility** all the way.

**1150 cities** served direct by air; air-rail to 18,000 off-airline offices.

**Experienced Air Express** has handled over 25 million shipments.

Because of these advantages, regular use of Air Express pays. It's your best air shipping buy. For fastest shipping action, phone Air Express Division, Railway Express Agency. (Many low commodity rates in effect. Investigate.)

**AIR EXPRESS**  
GETS THERE FIRST



**SCHEDULED AIRLINES of the U.S.**

A service of  
Railway Express Agency and the



Rates include pick-up and delivery door to door in all principal towns and cities

## THE ELECTRON ART

(continued from p 122)

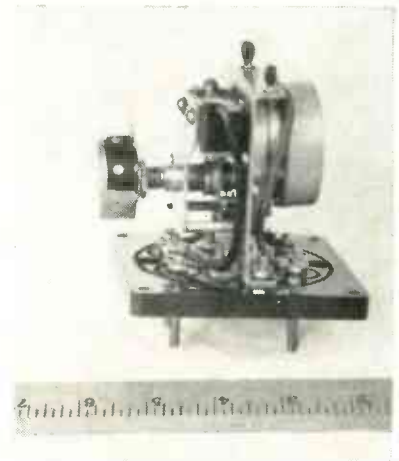

FIG. 2—Synchronous motor and spiral restoring spring are geared to control potentiometer. Snap-action switch, actuated by driveshaft cam, is closed at end of flyback

two minutes and restored the potentiometer to zero setting in approximately five seconds. In a newer unit, the flyback time is reduced to a fraction of a second by employing a magnetically controlled clutch coupling between the gear train and the restoring spring. During flyback, the gearing is decoupled from the potentiometer shaft.

The illustrated recordings indicate the essential features of the method. It offers considerable latitude in choice of motor speed and scale characteristic. An example of the type of problem to which this device may be applied is the measurement of the loss of radioactive sodium injected in tissue,<sup>1</sup> where the rate of decay is initially too rapid for direct counting with a scaling circuit and count register, and in the later stages, the radioactivity is too weak for its decay to be measured accurately with a rate meter.

### REFERENCE

(1) G. P. Burn and E. J. Harris, *Journ. Sci. Inst.*, 26, p. 126, 1949.

## Magnetic Modulation of Phototube Currents

TO AVOID the difficulties involved in successive stages of d-c amplification in measuring continuous values of light or heat flux, some means for chopping or otherwise providing an alternating signal is



# Specify **GUARDIAN** ELECTRONIC ENGINEERS

## HERMETICALLY SEALED RELAYS

NEAT

EFFICIENT

EASY-TO-SERVICE

VIBRATION-PROOF

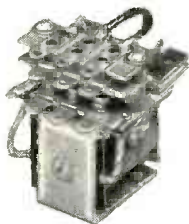

SERIES 335 RELAY



SERIES 595 RELAY

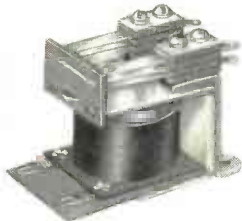

SERIES 610 AC—615 DC RELAY

Valuable information on HERMETICALLY SEALED Guardian Relays is yours for the asking. Write on your business letterhead for new completely descriptive and illustrated Catalog 5-H. No cost. No obligation.



THE SCREW TERMINAL TYPE



THE A. N. CONNECTOR TYPE



THE OCTAL PLUG TYPE



THE LUG HEADER TYPE

## TV CENTERING MAGNETS AND FOCUS COILS



### GUARDIAN CENTERING MAGNETS

The Guardian Centering Magnet compensates magnetically for any misalignment of the electronic beam or the focus coil assembly. Eliminates manual adjustment of the raster.

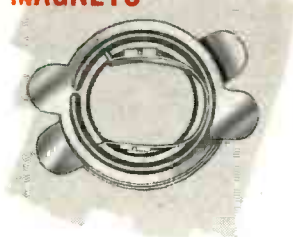

### GUARDIAN FOCUS COILS

Over a million Focus Coils have rolled off Guardian's production lines into TV sets of leading manufacturers. With more than 75 types established as *Guardian Standard*, speedy delivery to meet today's replacement needs is a matter of routine.



Write—ASK US TO MAKE SPECIFIC RECOMMENDATIONS. NO OBLIGATION.

# GUARDIAN ELECTRIC

1625 D W. WALNUT STREET

CHICAGO 12, ILLINOIS

A COMPLETE LINE OF RELAYS SERVING AMERICAN INDUSTRY

# NOW

# MET-L-FLEX

for

## DUAL SUSPENSION MOUNTING SYSTEMS

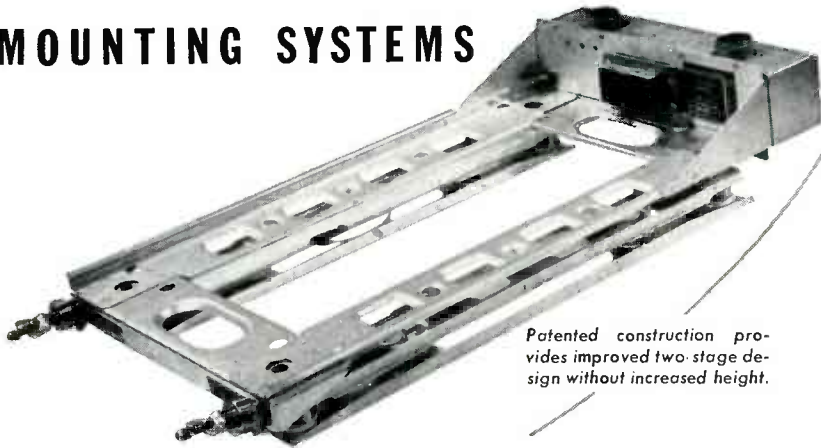

Patented construction provides improved two-stage design without increased height.

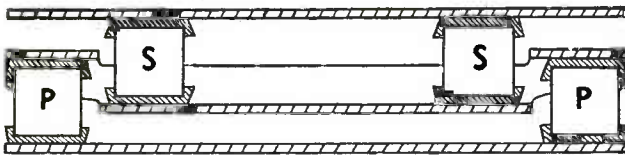

Primary Cushions (P) provide partial isolation. Remaining vibration reaching intermediate beams is isolated from equipment by secondary cushions (S).

To protect vital equipment in modern high speed and high altitude aircraft, Robinson Dual Suspension Mounting Systems with MET-L-FLEX, the all steel resilient material, provide the best solution to the complex problems of vibration isolation and shock absorption.

Robinson Mounting Systems incorporating MET-L-FLEX will operate uniformly through a wide range of temperatures (minus 80° C to plus 175° C). The inherent stability and isolation characteristics of the dual suspension principle combined with the non-linear deflection and high damping action of MET-L-FLEX (shown below) set a new standard for the mounting of all types of electronic equipment.

All Robinson Mounts meet or exceed the requirements of JAN-C-172A and are available in these form factors and beam assemblies, or special sizes to fit your equipment. May we have your inquiry?

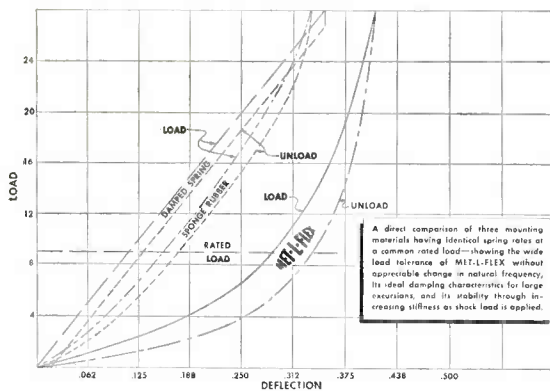

## ROBINSON AVIATION, INC.

TETERBORO, NEW JERSEY  
VIBRATION CONTROL ENGINEERS

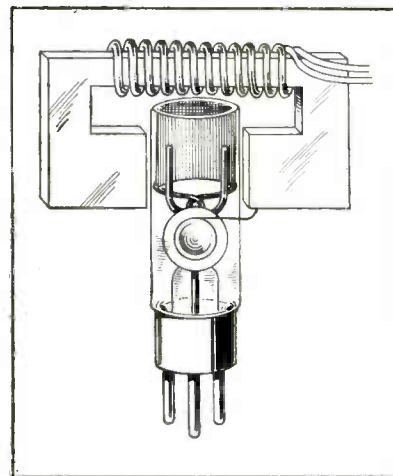

FIG. 1—Physical setup for magnetic modulation of phototube currents

often used to allow use of a-c amplifiers. A new method is described here. The space currents within the phototube are modulated with an alternating magnetic field applied transversely across the path of photoelectrons.

Figure 1 illustrates the basis for the system. The phototube is located between the poles of a magnet in such a way that the electrons are forced back to the cathode if the magnet coil is energized. Whenever the magnetic field is zero, the electrons are free to flow to the anode. The space-current modulation will, of course, be double in frequency compared with the frequency of the modulating wave.

The system described eliminates the harmful effects caused by the presence of leakage currents, since the leakage electrons are not modulated, as they are in systems which vary the output signal from the phototube electrically. No compensation or zero setting is required; with no light, there is no a-c output from the phototube. Compensation for line-voltage fluctuation may be provided automatically by overexciting the modulating coil slightly, since an increase in excitation beyond that point, as might occur if the line voltage rises, will decrease modulation, thereby compensating for accompanying increases in amplifier gain.

### Typical Instrument

For a high-sensitivity instrument which gives full deflection of the



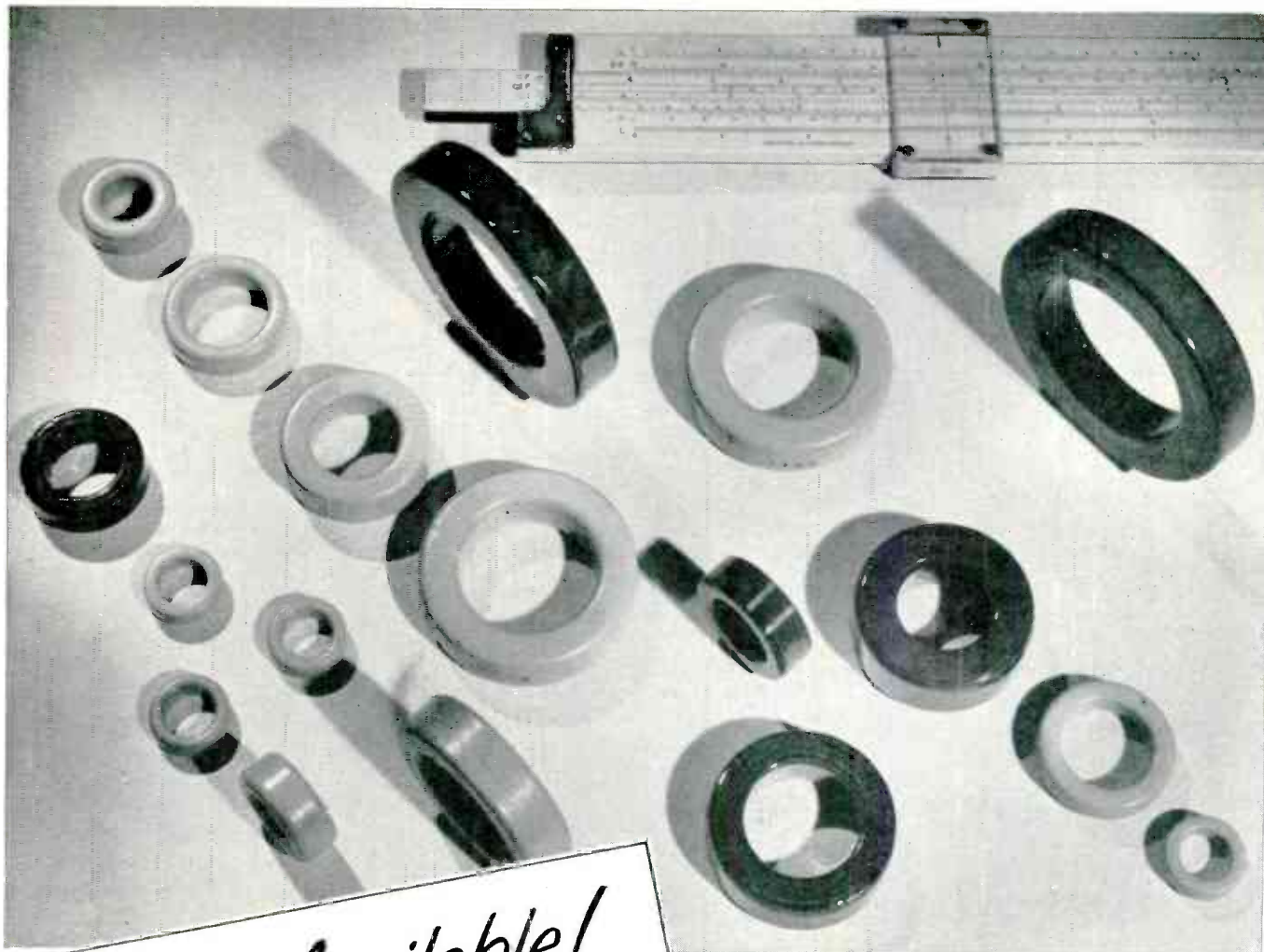

*Now Available!*  
**MOLYBDENUM PERMALLOY  
 POWDER CORES\***

**HIGH Q TOROIDS** for use in  
 Loading Coils, Filters, Broadband  
 Carrier Systems and Networks—  
 for frequencies up to 200 KC

**COMPLETE LINE OF CORES  
 TO MEET YOUR NEEDS**

- ★ Furnished in four standard permeabilities — 125, 60, 26 and 14.
- ★ Available in a wide range of sizes to obtain nominal inductances as high as 281 mh/1000 turns.
- ★ These toroidal cores are given various types of enamel and varnish finishes, some of which permit winding with heavy Formex insulated wire without supplementary insulation over the core.

For high Q in a small volume, characterized by low eddy current and hysteresis losses, ARNOLD Moly Permalloy Powder Toroidal Cores are commercially available to meet high standards of physical and electrical requirements. They provide constant permeability over a wide range of flux density. The 125 Mu cores are recommended for use up to 15 kc, 60 Mu at 10 to 50 kc, 26 Mu at 30 to 75 kc, and 14 Mu at 50 to 200 kc. Many of these cores may be furnished stabilized to provide constant permeability ( $\pm 0.1\%$ ) over a specific temperature range.

\* Manufactured under licensing arrangements with Western Electric Company.

W&D 2930

**THE ARNOLD ENGINEERING COMPANY**  
 SUBSIDIARY OF ALLEGHENY LUDLUM STEEL CORPORATION  
 147 EAST ONTARIO STREET, CHICAGO 11, ILLINOIS

# STEVENS BI-METAL THERMOSTAT

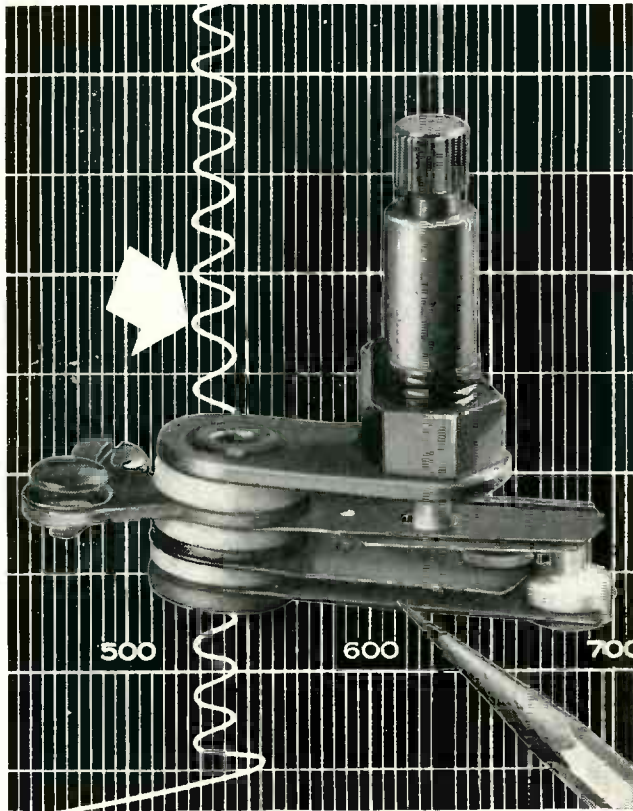

How do Stevens Type S thermostats differ from ordinary thermostats?

The pencil points to the *electrically independent* bi-metal; the arrow points to the *result*.

Do your products feature this precision temperature control?

But an independent bi-metal is *only part* of the Stevens temperature control story. Mounting stud on Type S thermostats is in direct metal-to-metal contact with controlled device for rapid, complete heat transfer and faster bi-metal response. Result: fewer contact operations . . . elimination of artificial cycling or "jitters". . . *longer thermostat life*.

Precision assembled only from quality materials and precalibrated in pots simulating actual service conditions, Type S thermostats insure satisfactory performance of your appliances and industrial apparatus.

Specify Stevens Type S thermostats—they *perform better . . . last longer*.

A-2735

Adjustable Type S illustrated. Other designs in any temperature range up to 650°F available. Write for data.

**STEVENS** manufacturing company, inc.  
MANSFIELD, OHIO

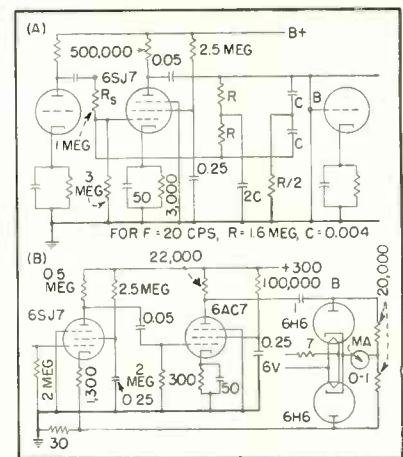

FIG. 2—Frequency-selective stage (A) and meter rectifier-amplifier stages (B) of the amplifier used in conjunction with a magnetically modulated phototube

meter with a light flux of 1 microlumen, a carrier frequency of 20 cps was chosen. The parallel-T circuit shown in Fig. 2A discriminates against all frequencies except 20 cps, at which there is a gain of 100, with a response characteristic as shown in Fig. 3. The rectifier circuit used is shown in Fig. 2B. A double-diode 6H6 is used as a full-wave averaging rectifier for the 70-ohm 1-ma meter. An effective voltage of 23 volts at the plate of the top half of the 6H6 will cause full meter deflection. Each diode is terminated by 20,000 ohms to avoid nonlinearity for small driving voltages. The filament voltage is reduced in order to minimize the zero reading.

The feedback loop provides the required 2 to 1 linearity. An input of 0.04 volt caused full meter deflection.

The gain of the parallel-T network stage is such that one stage between it and the phototube will raise the 180- $\mu$ v phototube signal

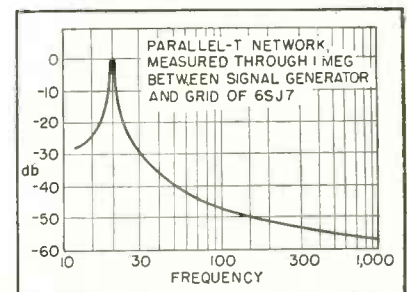

FIG. 3—Frequency response curve of the parallel-T circuit shown in Fig. 2A



# FIELD-PROVED and ACCEPTED thousands in daily use!

**AMPROBE**  
THE ONLY POCKET-SIZED  
SPLIT-CORE VOLT-AMMETER

1/2 the usual size! only 7"

1/3 the usual weight! only 14 oz.

1/2 the usual price! only \$42<sup>75</sup>

measures current instantly, safely, accurately  
without interrupting circuit or breaking  
insulation of conductor!  
also gives quick, accurate voltage readings.

Engineers who've already discovered the Amprobe agree: It's one of the most *useful* instruments they've ever owned. Here's why:

**AMPROBE** is so compact, you can actually slip it into your hip pocket.

**AMPROBE** gives you an instant current reading "right on the nose" without touching or breaking the insulation of the conductor, or interrupting the circuit. (You just press the trigger to open the spring-controlled jaws; then release the trigger and take current reading.)

**AMPROBE** is ruggedly constructed and can be roughly handled without fear of breakage.

The Amprobe has now been accepted as the development that takes the split-core volt-ammeter out of the "expensive heavy equipment" class and makes it a *personal instrument*, worth its weight in gold to the busy engineer who can't be heavily burdened.

**A "MUST" FOR MANUFACTURER'S FIELD ENGINEERS!**

Once you've held the Amprobe in your hand, once you've discovered how convenient it is to carry and to use, you'll understand why an Amprobe in the hip pocket is fast becoming a "must" instrument for either field or laboratory work. Send today for Bulletin 109D. PYRAMID INSTRUMENT CORP., 49 Howard Street, New York 13, N. Y.



Complete with plug-in type voltage test leads and genuine top grain cowhide leather case.

THE AMPROBE\* IS AVAILABLE IN THREE MODELS:

**MODEL A-5**

AMPERES: 0/6.5/13/  
26/65/130 amps  
VOLTS: 0/130/260  
VAC

**MODEL A5-1**

AMPERES: 0/6.5/13/  
26/65/130 amps  
VOLTS: 0/150/600  
VAC

**MODEL A-6**

AMPERES: 0/10/25/  
50/100/250 amps  
VOLTS: 0/150/600  
VAC

FREQUENCY: 50-70 cycles

VOLTAGE BREAKDOWN TEST: 3,000 Volts A.C.

ACCURACY: ± 3% (of full scale deflection)

SCALE LENGTH: 2.47 inches

SEND FOR  
DESCRIPTIVE  
LITERATURE:

PYRAMID INSTRUMENT COMPANY  
49 Howard Street, New York 13, N. Y.

Dept. ET-40

Please send me Bulletin 109D describing the Amprobe\* split-core volt-ammeter.

Name.....

Company.....

Address.....

City..... Zone..... State.....

Our local electrical or radio distributor is:.....

**A PYRAMID INSTRUMENT**  
available at the better electrical and radio distributors

 MOSINEE doesn't count its success in terms of big volume records. More important to us is the aid that MOSINEE "paperologists" and facilities provide our customers.

If you have a problem involving paper . . . if you require specific technical characteristics such as high tensile or tear strength, accurate caliper, density, liquid repellency or absorbency, good dielectric strength, specified pH for maximum-minimum acidity or alkalinity . . . and above all, if you want to be sure of *dependable uniformity* . . . it will pay you to specify "MOSINEE." For consultation with MOSINEE technicians, without obligation to you, please write Dept. E.

# MOSINEE

*"More than Paper"*



MOSINEE PAPER MILLS COMPANY • MOSINEE, WISCONSIN

*"Essential Paper Manufacturers"*

to the required level. This first stage, which acts essentially as an impedance transformer, should have a gain of 2.2. Additional parallel-T networks may be used to eliminate 60 and 120-cycle hum from the low-level stages.

In a paper presented at the AIEE Winter meeting, Henry P. Kalmus of the National Bureau of Standards announced that a light-meter using the principles summarized here is more stable and has higher sensitivity than other commercial types, and has the advantage of requiring no zero adjustment.

## Study of Skin Impedance

By ROBERT C. BURNS  
Stanford University  
Stanford, California\*

POTENTIALS generated by the contractions of muscles and muscle fibers are recorded and studied with the aid of electromyograph equipment. An attempt is then made to interpret the records in terms of absolute physical movement. In this interpretation there exist three major variables: frequency, phase, and amplitude. The frequency spectrum to be analyzed appears largely between 40 and 500 cycles per second, the signal amplitude generated by the muscle reaches a peak around 200 microvolts, and the phase of electrical measurement depends on the reactive elements acting in the entire measuring scheme.

These three interrelated factors can be fairly well controlled in the electrical amplifying device, but the question arising is, "What happens within the muscle, and what is actually measured between the two electrodes?" It follows then, "What source impedance does the muscle potential act through?"

Most of the past publications have mentioned, in a loose fashion, that the skin behaves like a leaky capacitor. This paper attempts to evaluate this past statement in terms of more definite quantities so

\* Now at Department of Electrical Engineering, North Dakota State College, Fargo, North Dakota.





“...and last year’s sales prove we made a profitable move by building **Counters** into our products”

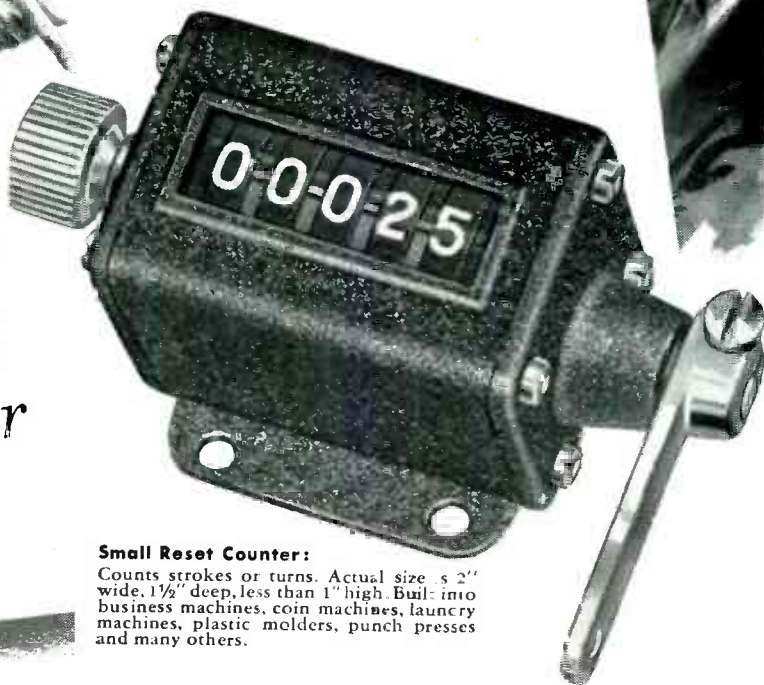

**Small Reset Counter:**

Counts strokes or turns. Actual size is 2" wide, 1 1/2" deep, less than 1" high. Built into business machines, coin machines, laundry machines, plastic molders, punch presses and many others.

**ANNUAL REPORTS** often show a surprising surge in sales . . . when Veeder-Root Counters are built into a product to give it an extra usefulness that makes customers take a new interest.

For Veeder-Root Counters put “Facts-in-Figures” to work in many ways . . . to prove a product’s guarantee . . . to tighten control of production, inventory, purchasing . . . to spot errors, delays, waste . . . even to control ma-

chine-operation . . . and many other services that customers find desirable in any type of product.

Yes, there may be “hidden talents” in *your* product, too . . . talents for counting in new ways that will be helpful to *your* customers. And who’s to say about this? Well, why not put it up to Veeder-Root engineers? They’ve discovered more unsuspected profits in more products than you could shake an Annual Report at! *Write.*



**COUNTING DEVICES**

Send for 8-page “Count Book” that shows all types of Veeder-Root Counters for mechanical, electrical, and manual operation. Address:

VEEDER-ROOT INC., HARTFORD 2, CONN.  
*In Canada:* Veeder-Root of Canada, Ltd., 955 St. James Street, Montreal 3.  
*In Great Britain:* Veeder-Root Ltd., Kilspindie Road, Dundee, Scotland.

# Veeder-Root **COUNTERS**

# RCA TELEVISION COMPONENTS

## THE STANDARDS OF THE INDUSTRY



RCA-209R1 Horizontal  
Linearity Control

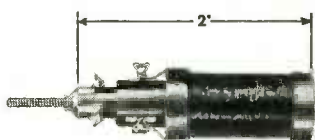

RCA-208R1  
Width Control

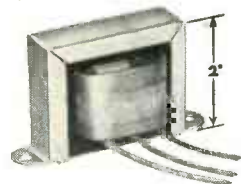

RCA-222T1 Vertical-  
Deflection-Output  
Transformer



RCA-206D1  
Deflecting Yoke

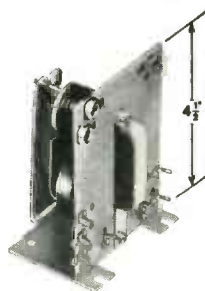

RCA-218T1 Horizontal-  
Deflection-Output and  
High-Voltage Transformer

### RCA-Engineered TV Components for wide-angle deflection systems

THE TV COMPONENTS illustrated represent a new high in co-ordinated circuit design. Used in conjunction with the newly developed RCA-6CD6-G and 6S4 tubes, these components provide a completely integrated high-efficiency, wide-angle deflection system for the 16GP4 . . . or other television picture tubes having a deflection angle of 70 degrees and operating at anode voltages up to 14 kilovolts.

All RCA television components

are "originals," designed to fit the *tube and circuit* with characteristics which are correct both electrically and mechanically. They are "performance proved" and competitively priced.

RCA Application Engineers are ready to work with you in the adaptation of RCA television components to your particular designs. For further information, write RCA, Commercial Engineering, Section D42S, Harrison, N. J., or your nearest field office.

(EAST) Harrison 6-8000, 415 S. 5th St., Harrison, N. J.

(MIDWEST) Whitehall 4-2900, 589 E. Illinois St., Chicago, Ill.

(WEST) Trinity 5641, 420 S. San Pedro St., Los Angeles, Calif.



**RADIO CORPORATION of AMERICA**  
ELECTRONIC COMPONENTS HARRISON, N. J.

that muscle source potentials may be more accurately determined.

#### Electrodes Used

There are two types of electrodes in use: the sub-dermal and the surface type. The former are simply needles which, inserted into the muscle, provide the potential measurement. The latter are metallic disks placed on the surface of the skin, in the vicinity of the muscle, with or without prior skin preparation. This paper will be largely concerned with the surface electrode. Size, shape, spacing and application of the electrodes are factors which enter into each impedance measurement. These will be discussed later. All measurements described herein were made on the skin of the pre-tibial area.

Four tests were made with three-fourths inch diameter copper electrodes separated one inch between edges under the following conditions: (1) shaved and dry skin, (2) shaved skin with electrode paste applied, (3) shaved skin with surface then sanded, and (4) shaved skin, sanded surface, and electrode paste applied. The graphical results obtained are presented in Fig. 1. The four curves represent the measurements made on one subject using the above-mentioned electrode applications in the order listed.

A study of the curves of Fig. 1 indicates a much higher impedance for application 1 than for application 4. This is quite outstanding at the lower frequencies. However, the most striking difference is the nearly constant impedance with application 4. This indicates an im-

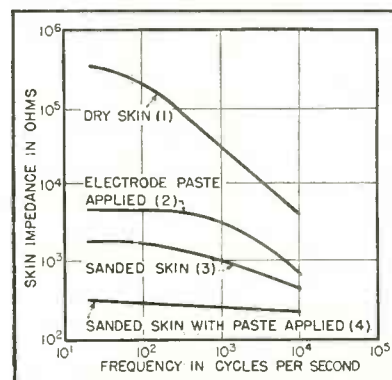
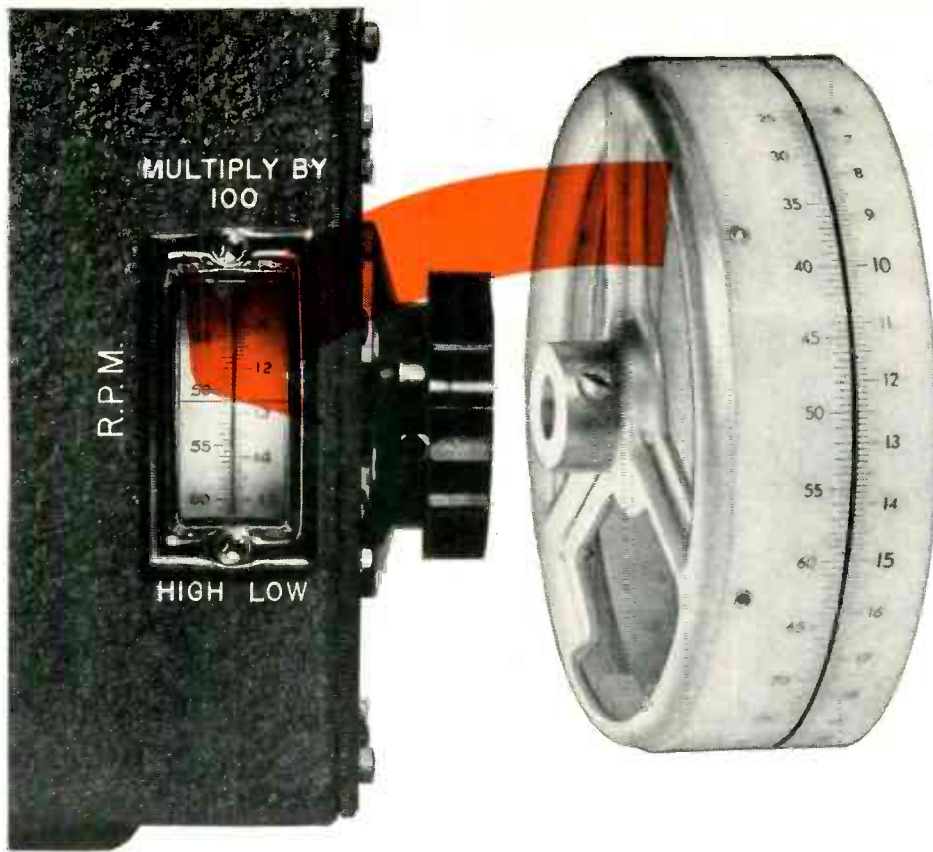

FIG. 1—Skin impedance, with  $\frac{3}{4}$ -inch electrodes applied to sanded skin with electrode paste, is almost entirely resistive, as indicated by constant impedance for changing frequency





GENERAL RADIO COMPANY, Cambridge, Mass., uses flexible Translucent Lamicoïd for the rear-illuminated dial of the Stroboscac, a small, portable stroboscope.



## ENGRAVING, TRANSLUCENT, GRAPHIC *Lamicoïd*

make instrument dials readable, accurate, durable

Big calibration figures on Engraving, Translucent or Graphic Lamicoïd make instrument dials easy to read, easy to set accurately. Lamicoïd's dimensional stability means long-lasting service, too. It stands up to heat and cold, resists moisture, oils, solvents and corrosive vapors. Maintenance? Just wipe with a damp cloth to clean!

Engraving Lamicoïd is a sandwich type material. Markings engraved through the surface to the contrasting opaque or translucent core stand out clearly, can't wear away.

Figures applied by painting, printing or silk screen process on Translucent Lamicoïd show up against rear illumination. Its flexibility permits formation of simple curved shapes.

Graphic Lamicoïd incorporates printed matter laminated under a transparent surface on one or both sides of the sheet.

This line of materials, ideal for dials, circuit diagrams, signs, instrument panels and charts, is unexcelled for clarity and durability. For further information about these and other products of our 56 years of experience in making highest quality electrical insulation, contact our nearest sales office.



**MICA** *Insulator* **COMPANY**

Schenectady 1, New York

*Offices in Principal Cities*

THERE'S A  
**VICKERS**  
*Standard*  
**MAGNETIC  
 AMPLIFIER  
 TO FIT YOUR  
 CONTROL  
 NEEDS**



NOW — for the first time — you can select a standard magnetic amplifier — to serve your 60-cycle control application. Vickers supplies from stock 28 styles — pre-engineered and laboratory tested with a choice of d-c or a-c output. Power (output) levels range from milliwatt to 108 watts maximum (d-c output).

Comprehensive application data sheets are furnished to help you select the Vickers magnetic amplifier for your control needs.

**A FEW OF THE MANY APPLICATIONS**

• Line-to-line Voltage Regulators • Hydraulic Transmission Controls • A-c and D-c Generator Voltage Regulators • Controls Relays • Speed and Frequency Regulators • Lamp and Furnace Controls • Temperature Regulators • Time Delay Devices

**READY NOW — THE VICKERS EDUCATIONAL MAGNETIC AMPLIFIER**

Designed for school and industrial laboratory use, it permits study of all basic single-phase self-saturating circuits. Complete with Laboratory Experiment Manual and Magnetic Amplifier Design Handbook.

• Write today for complete information on the Vickers Educational Magnetic Amplifier and for your copy of the Vickers Magnetic Amplifier Design Handbook which specifies characteristics and illustrates circuits. Please make request on your letterhead.



**VICKERS ELECTRIC DIVISION**

**VICKERS Inc.**

1801 LOCUST STREET • ST. LOUIS 3, MISSOURI

pedance which is nearly entirely resistive. With such an electrode application the output potential available at the electrodes is nearly independent of the period of the transient generated by the muscle contraction. This important factor makes many assumptions valid with small error.

*Detailed Study*

To study the internal impedance further a more extensive search was made; the results appear in Fig. 2. A flattening of the impedance curve at both the high and low

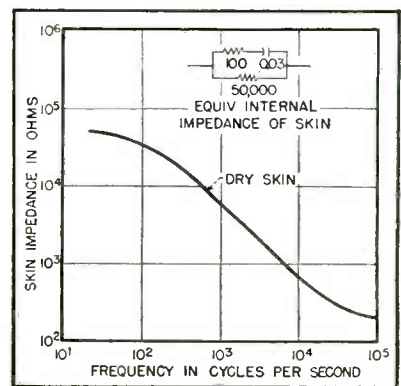

FIG. 2—Flattening of impedance curve at high and low frequencies indicates resistive component of the internal tissue structure of the muscle. Insert shows equivalent internal impedance of the skin

frequencies indicates an asymptotic resistive component of the internal tissue structure of the muscle. The curve may be divided into three major segments and the equivalent electrical behavior determined. A simplified version of the equivalent internal impedance of the skin is shown in the insert of Fig. 2.

*Equivalent Skin Impedance*

The values of these three parameters are affected by each electrode application. Nevertheless, the relative value of the parameters, especially the capacitor, are indicated. It might be expected, since there exists such a large difference between shunt and series resistors, that the slope of the impedance curve should be unity during a portion of the frequency-impedance graph. However, since the internal tissue is of quite complex nature,



# SMALLEST

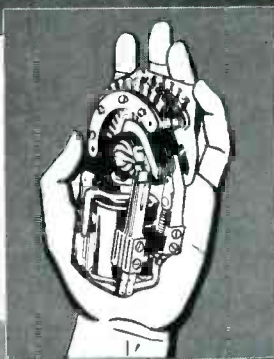

# LIGHTEST FASTEST

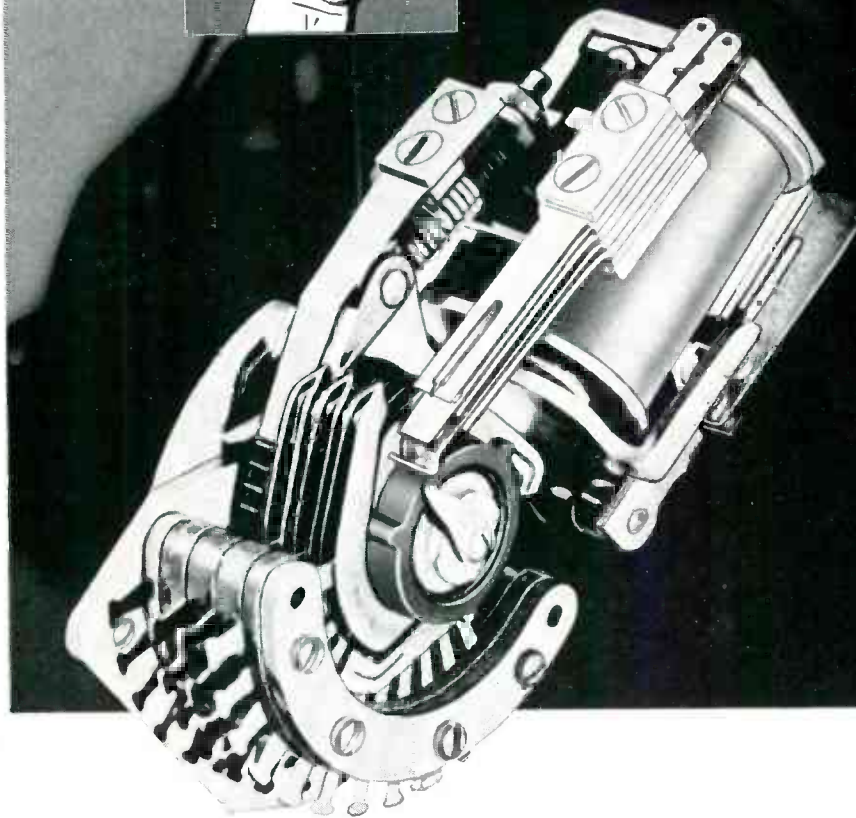

*type 44* **STEPPING SWITCH**

**Up to 6 Levels — 10-point plus home; yet it's Smaller Than Your Hand!** Only  $4\frac{1}{2}$  inches long — and about half that wide — Automatic Electric's new stepping switch averages only  $13\frac{1}{2}$  ounces in weight. Yet it gives you *more* than other larger switches.

*It's speedy...* a typical three-level 10-point switch, at 48 volts D. C., self-interrupted, runs approximately 80 steps a second — impulse controlled, at 35 steps a second.

*It's smoother...* brush springs are in an "11th" position; wipers pass over them exactly as over bank contacts. No double load in any position — no "galloping."

*It assures long life...* smooth operation means longer life; in addition, all driving parts are especially armored against wear. In rigid laboratory tests, Type 44 Stepping Switches averaged 20,000,000 operating

cycles (200 million steps!) and then required only minor readjustment.

*It's adaptable...* meets your specific needs with a wide range of coils (for any D. C. voltage up to 110), bank levels, bridging and non-bridging wipers, interrupter springs and off-normal springs.

The Type 44 Stepping Switch has *less* weight — takes *less* space — and gives you *more* of everything else! Get complete data NOW on this revolutionary new switch. Call, wire, or write AUTOMATIC ELECTRIC SALES CORPORATION, 1033 W. Van Buren St., Chicago 7, Ill. In Canada: Automatic Electric (Canada) Limited, Toronto.

RELAYS  SWITCHES  
**AUTOMATIC ELECTRIC**

CHICAGO

# FOR A NEW HIGH IN HIGH FIDELITY!

## University MODEL 6201 COAXIAL SPEAKER



### CUTAWAY VIEW

showing coaxial arrangement of rugged 12" cone and full size tweeter with cobra horn, built-in LC frequency dividing network and new super efficient W shaped Alnico 5 magnet.



**CONTINUOUS POWER:**  
20 watts of integrated program material

**NOMINAL IMPEDANCE:**  
6-12 ohms

**FREQUENCY RESPONSE:**  
45 to 15,000 cycles

## Leading again in PRICE AND QUALITY!

**ECONOMY**—The Model 6201 is one of the greatest coaxial speaker values ever offered. Despite its economical price, it offers no compromise in efficiency, response, or power handling capacity. A listening test in comparison with higher priced competitive speakers is the most convincing demonstration we can suggest to substantiate these claims.

**MANY NEW FEATURES**—These include an oversize woofer 2" voice coil capable of extreme excursion for perfect low frequency response, a professional driver—driven tweeter

unit with "cobra" shaped horn for clean, wide angle projection of the highs, and a built-in LC type frequency dividing network with a variable attenuator.

**UNIVERSAL REPLACEMENT**—The self-contained features of the Model 6201 permit rapid, easy replacement of any standard speaker for conversion to high fidelity reproduction. Only two wires to connect and the job is complete. Ample cable is provided for mounting the attenuator control in any convenient location.

WRITE DEPT. E FOR ILLUSTRATED CATALOG



**University**  
**LOUDSPEAKERS INC**  
80 SO. KENSICO AVE., WHITE PLAINS, N. Y.

Famous World-Wide for LOUDSPEAKERS • DRIVER UNITS • TWEETERS • PORTABLE POWERSPEAKERS

the slope of the curve did not quite reach unity.

Measurements made on electrode separation showed no large variation after the separation exceeded one-half inch. The effect of electrode size was noticeable by a small increase in impedance with a decrease in electrode size. The diameter-to-spacing ratio was revealed as the most important relationship. This was reflected by measurements made with the subdermal electrodes. It was expected that the internal impedance would be quite low with the needles inserted in the muscle, but it was found that the impedance exceeded that of application 4 by a slight amount. It is believed that the small surface area of the needles contributed to this fact.

From the experimental data obtained the electrode application should consist of shaving the hair, sanding the surface, and the application of electrode paste for minimum skin impedance. With this type of application, variations in the resulting signal measured between electrodes, due to reactive effects, can be minimized. With further and more detailed study for each case, perhaps an absolute evaluation of muscle activity can be made. This knowledge of source potential should be useful in the study of isolated spastic muscles.

### Acknowledgement

The author is indebted to Marian Williams and Lucille Daniels, of Stanford University, for the opportunity to make this study. Also, many thanks to the many students of physical therapy at Stanford who contributed their time so patiently.

## Resistor Behavior at High Frequencies

VARIOUS types of resistors exhibit different characteristics when operating in the region above ten megacycles, depending on their physical size, nature of resistance element and physical location. The analysis of an isolated resistance element was first considered by Howe<sup>1</sup> and later by Hartshorn<sup>2</sup>. It has been





The new Type 1023-A Amplitude Modulator, while designed particularly for use with the G-R Type 1022-A F-M Generator, may be used equally as well with other standard-signal generators at frequencies between 5 Mc and 220 Mc. It produces an amplitude-modulated signal with no appreciable incidental f-m. A feature of this modulator when used with the Type 1022-A Generator is the i.f. operating range switch which provides a gain of 10 at the 10.7 Mc standard f-m receiver intermediate frequency. Output voltages up to 3 volts can be obtained without serious envelope distortion. The output impedance is exceptionally constant.

**TYPE 1023-A AMPLITUDE MODULATOR \$250.00**



For measurements of r-f sensitivity on balanced lines for f-m and tv bands, the Type 1000-P5 V-H-F Transformer plugs into a standard-signal generator having a 50-ohm unbalanced output and supplies an equal balanced open-circuit voltage behind a 300-ohm balanced impedance. Its frequency range is 50 Mc to 250 Mc.

**TYPE 1000-P5 V-H-F TRANSFORMER . . . \$27.50**

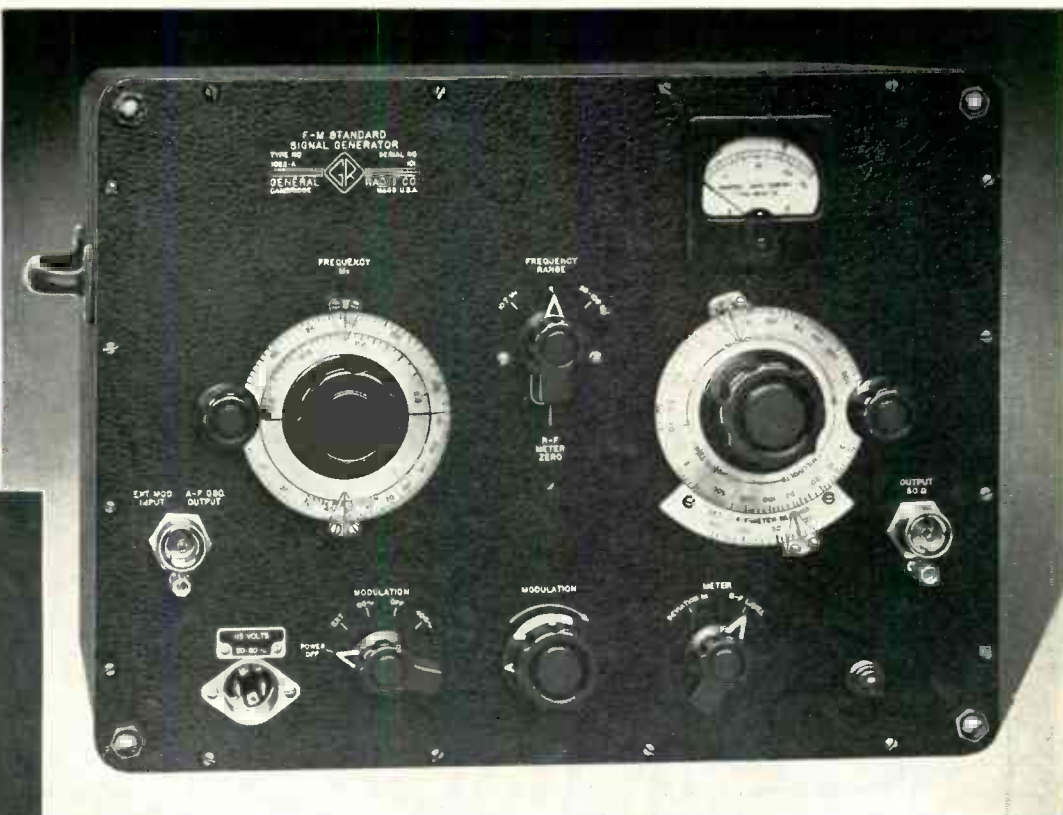

## FOR TESTING F-M BROADCAST RECEIVERS

**SIMPLE • INEXPENSIVE • NO SPURIOUS SIGNALS**

**T**HIS new G-R Standard-Signal Generator is designed especially for testing f-m broadcast receivers. All unessentials have been omitted in order that it can be moderately priced. Its features include:

- **Carrier Frequency Ranges** — 10-11.5 Mc and 88-108 Mc
- **Very Low Incidental Amplitude Modulation** — less than 5%
- **F-M Noise Level Very Low** — more than 50 db below 75 kc deviation
- **Slow Drift** — less than 0.005% after 20 minutes operation
- **High Output Voltage** — 88-108 Mc from less than 0.1 mv to more than 1 volt; open circuit; 10-11.5 Mc from less than 0.1 to 0.25 v
- **No Spurious Signals in Output System** — generates only *one* frequency
- **Extra-Low Generator Leakage** — undetectable on high-grade commercial f-m receiver
- **Semi-Logarithmic Meter Scale** — easier to read low deviations
- **Constant and Purely Resistive Output Impedance** — 50 ohms nominal
- **Auxiliary Tuning Scale** — for easy interpolation, 200 kc intervals on 88-108 Mc range and 20 kc on 10-11.5 range

**TYPE 1022-A F-M STANDARD-SIGNAL GENERATOR . . . \$625.00**



# GENERAL RADIO COMPANY

Cambridge 39, Massachusetts

90 West St., New York 6    920 S. Michigan Ave., Chicago 5    1000 N. Seward St., Los Angeles 38

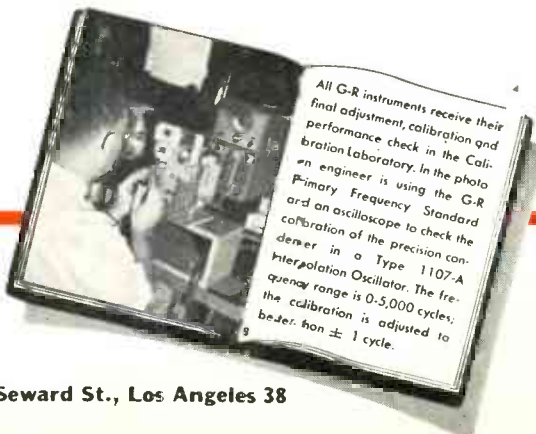

# MODERN ELECTRONIC DESIGN MEANS PLUG-IN UNIT CONSTRUCTION

With basic elements as units—that plug-in, slide-in, lock-in, break away easily—so that electronic equipment is instantly accessible—ready for rapid checks, servicing, and unit replacement.

More and more engineers are finding that plug-in unit construction is the type of design that makes many of the new complex electronic projects feasible to operate and maintain. It's also recognized that plug-in, unit principles make present electronic equipment much more practical for wider general use.

Up to now there has been no one place where components specifically designed for plug-in, unit construction were available. To get this type of construction—it has been necessary for engineers to design and have parts custom made or improvise with standard components in make shift arrangements.

Here at Alden's we are designing and manufacturing components for plug-in unit construction. We are setting up to work with manufacturers on as many of these problems as possible. Very frankly, much of our work is still in the pilot run stage—but, in every instance—proven in use. If you don't see the answer to your problems here—let us work it out with you.

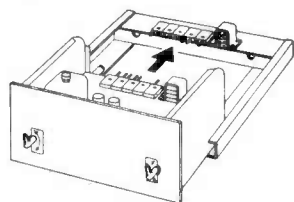

Back connected chassis—become instantly accessible. Half twist of handles brings chassis into place or ejects—no matter how heavy. Built for racks or as separate units—miniature and standard sizes.

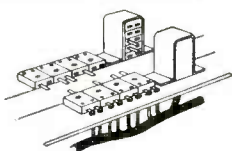

Rugged color coded back connectors—make and break circuits—provide rapid circuit checks. Wide mating tolerances compensate for any chassis misalignment. Miniature and heavy duty sizes.



Top operated clamps for tubes and plug-in units. Take minimum of space. Can be operated in cramped locations. Free floating—orients unit to socket without straining or bending pins.

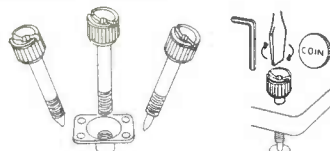

Alden Cap Captive Convenience Screws—Hold miniature chassis, heavy plug-in cans or detachable mechanical units securely. Assemble easily in production by power tools—yet any tool or coin services in field.

At last—a base specifically designed for plug-in units. No more broken bosses, bent pins, "shorted" circuits.

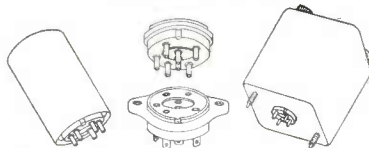

More and more engineers have been unitizing the basic elements of their circuits into compact, easily replaceable plug-in units. Since the conventional octal and tube socket bases have been the only component readily available, they have been constantly plagued by the broken bosses, bent pins, and "shorted" circuits caused by these bases.

This suggested an entirely new approach was necessary, so we went to work with some of these engineers. Out of this work the Alden-Noninterchangeable plug-in base was developed.

Pins have been made strong and stubby—for long, rugged use. The boss is eliminated entirely. Slight lead of center pins and locating rings with marker in the socket allow quick lining up of plug-in units. Further, this base is supplied with 2 to 11 contacts—in variable pin patterns—so that even where the same number of contacts are used, the pin layout may be varied so only the correct unit will mount in its proper socket. Pin patterns can even be selected to isolate critical voltages or signals.

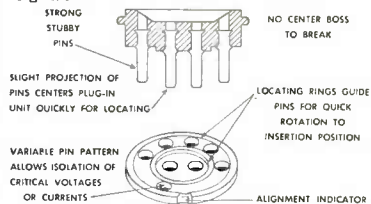

Write today for literature and samples. Let Alden work with you on your components for plug-in, unit construction.

found that experimental values compare quite well with theoretical values.

The experimental equipment used in determining the behavior of resistors at high frequencies includes two G-R resistance bridges, a Measurements Corp. signal generator, and a Hallicrafters SX-42 receiver which served as the detector. Various values of resistors between 50 and 77,000 ohms were measured, and their equivalent resistances calculated by Hartshorn's method.<sup>2</sup>

It was found that for standard types, the equivalent resistance of a resistor decreases more rapidly with frequency for high d-c value resistors than for low-value resistors. For the same value of d-c resistance, the smaller the physical

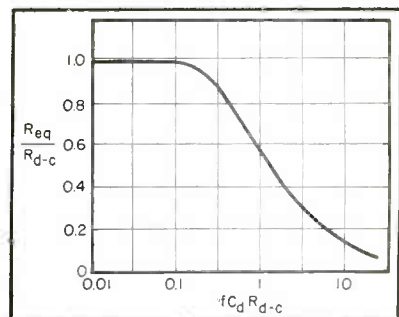

Hartshorn's curve for predicting the behavior of resistors at high frequencies. Distributed capacitance  $C_d$  is that of the isolated resistor plus the proximity effects

size of the resistor, the better are its high-frequency characteristics.

The carbon type proved to be superior to composition for high-frequency work, but both of these types are inferior to resistors made with a carbon coating on an insulator. Wire-wound resistors are too reactive for use as resistors above about 10 mc. For resistors whose construction permits analysis by Hartshorn's calculations, the experimental and calculated values conform within 10 percent. Thus it may be concluded that the equivalent resistance of almost any resistor under one megohm may be predicted with fair accuracy from Hartshorn's curve, shown above. The falling off of resistors of greater d-c value may be explained qualitatively by combining this and

Write for new booklet on "Components for Plug-in Unit Construction"

**ALDEN PRODUCTS CO.** 117 NORTH MAIN ST. BROCKTON 64, MASS.



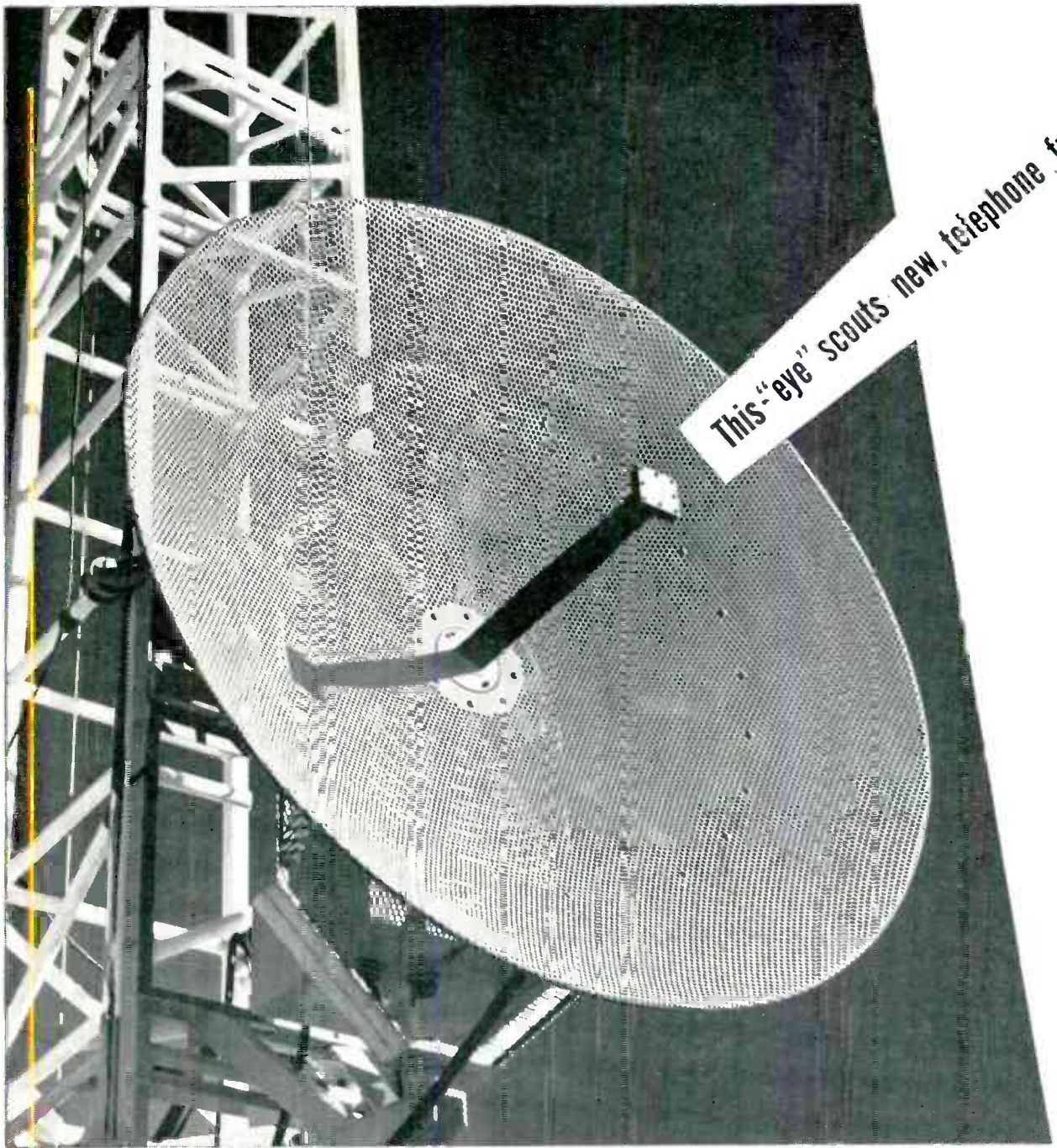

This "eye" scouts new, telephone frontiers

Throughout history, scouting parties have gone out ahead of man, ahead of settlements, ahead of civilization itself. Today, Bell System scouts are engaged in a new kind of exploration — charting a path for microwaves — using equipment specially designed by Bell Telephone Laboratories.

The portable tower shown is constructed of light sections of aluminum and in a few hours may be built up to 200 feet. Gliding on roll-

ers, the "dish," with its microwave transmitter or receiver, is quickly positioned for line-of-sight transmission, then oriented through electric motors controlled from the ground.

Test signals show how terrain and local climate can interfere with microwave transmission. Step by step, Bell's explorers avoid the obstacles and find the best course for radio relay systems which will carry television pictures or hun-

dreds of simultaneous telephone conversations.

A radio relay link similar to the one between New York and Boston will be opened this year between New York and Chicago. Later it will be extended, perhaps into a nation-wide network — another example of the way Bell Telephone Laboratories scientists help make the world's best telephone system still better each year, and at lowest cost.

**BELL TELEPHONE LABORATORIES**



EXPLORING AND INVENTING, DEVISING AND PERFECTING, FOR CONTINUED IMPROVEMENTS AND ECONOMIES IN TELEPHONE SERVICE

# ALUMINUM FABRICATION

## "Donnelly Can Do It!"



Donnelly Manufacturing is supplying aluminum sheet metal work of all types to meet the most exacting Army, Navy and Air Corps specifications. All Donnelly men and equipment are U. S. Armed Forces certified. *That's why you can be sure Donnelly can do your toughest aluminum fabricating job better, cheaper, faster.*

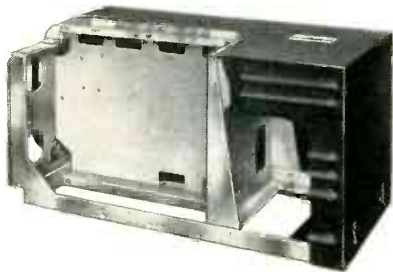

**DONNELLY DID IT!**

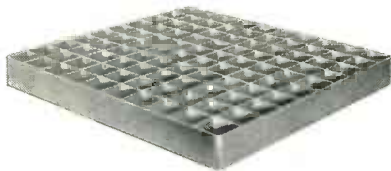

5-point superiority:

(1) Better engineering (2) Complete equipment (3) Unexcelled sheet metal "know-how" (4) Facilities for producing any type of finish (5) Greater economies thru improved methods.

# DONNELLY

**ELECT. AND MFG. CO.**

DIVISION OF

**JOHN DONNELLY & SONS**

1850—1950

3050 WASHINGTON ST., BOSTON

PLEASE SEND ME YOUR FOLDER, LISTING YOUR EQUIPMENT, FACILITIES AND EXPERIENCE IN SHEET METAL WORK.

NAME \_\_\_\_\_  
 DEPT. \_\_\_\_\_  
 COMPANY \_\_\_\_\_  
 ADDRESS \_\_\_\_\_  
 CITY \_\_\_\_\_ STATE \_\_\_\_\_

the Boella effect.

The Boella effect<sup>3,4</sup> theory states that the molecules of the resistance element are separated by minute insulators which form capacitors. This is, however, strictly a qualitative theory and would be extremely difficult to analyze on a quantitative basis. This effect may be neglected for values less than one megohm; higher values contain much more nonconducting material in their composition, thereby giving rise to an increased number of the minute capacitors mentioned above.

This experimental verification of the theoretical characteristics of resistances at high frequencies was described by George R. Arthur and Samuel E. Church of Yale University in a research report for the U. S. Signal Corps and presented orally by H. L. Krauss, also of Yale, at the 1950 IRE National Convention.

#### REFERENCES

- (1) G. W. O. Howe, *Wireless Engineer*, 12, June 1935.
- (2) L. H. Hartshorn, *Wireless Engineer*, 15, July 1938.
- (3) O. S. The Behavior of High Resistances at High Frequencies, *Wireless Engineer*, 12, p 303, June 1935.
- (4) Mario Boella, *Alta Frequenza*, 3, Apr. 1934.

### Wide-Range Electrostatic Generating Voltmeters

ELECTROSTATIC generating voltmeters find wide application in industrial and experimental applications, where a vectorial measurement of an electric field intensity, in volts per meter, is required.

By suitable distribution of several electrostatic generating voltmeters over the surface of a rocket projectile, it is possible to separate the field due to a charge on the rocket from that due to potential gradients already existing in regions above the earth. To evaluate these electric field components, several recent Aerobee and V-2 projectiles have carried electrostatic generating voltmeters. Figure 1 shows a drawing of the equipment used to measure fields from 1 to 10,000 volts per meter. The rotor consists of six blades, rotating at 5,000 rpm, while the stator is



a  
“live  
wire”  
for



hot

spots

**Vitrotex\* Magnet Wire** with Glass Fiber Insulation  
withstands temperatures of 130°C.

**Highly Flexible . . . Amazing Space Factor** — made possible by insulation of alkali-free glass, the insulation that's soft as silk and strong as steel!

**High Dielectric Strength and Smooth Surface . . .** resists moisture, acids, oils and corrosive vapors!

**Vitrotex Windings Give Tighter, Safer Coils** — for operation in confined spaces under high heat!

*Ask the Anaconda Sales Office nearest you for complete information on the entire ANACONDA Magnet Wire Line. Anaconda Wire & Cable Company, 25 Broadway, New York 4, N. Y., or 20 N. Wacker Drive, Chicago 6, Ill.*

\* Reg. U. S. Pat. Off.

50322

The right wire for the job **ANACONDA**<sup>®</sup>  
**WIRE AND CABLE**

# AIRBORNE High Frequency ANTENNAS are born in WORKSHOP LABORATORIES...

For the U. S. Air Force rocket program, Workshop engineers have developed a unique antenna system. Strategic placement of flush-mounted slot antennas around the rocket provides essentially isotropic radiation for optimum reception by ground stations. The related problems of frequency, power distribution and phasing were solved by Workshop engineers to make this notable achievement.

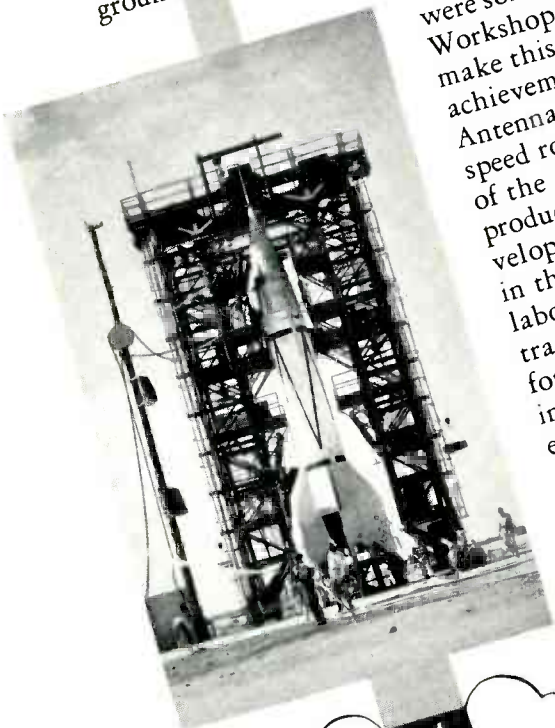

Antennas for high speed rockets are typical of the specialized products being developed regularly in the Workshop laboratories. Under contracts with the armed forces and private industry, Workshop engineers constantly work to solve the most difficult antenna problems.

Specialists in High Frequency  
**THE WORKSHOP ASSOCIATES, Inc.**  
84 NEEDHAM STREET, NEWTON HIGHLANDS 61, MASSACHUSETTS



Antennas

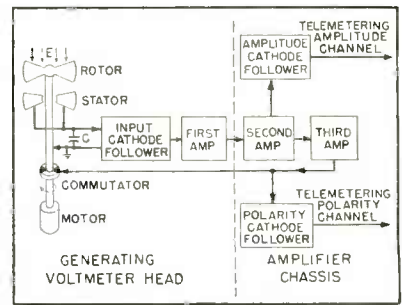

FIG. 1—Electrostatic generating voltmeter setup for covering a dynamic range of from 1 to 10,000 volts per meter

stationary but similarly shaped.

In describing the theory of operation in *Instruments*, November, 1949, John F. Clark, Jr., points out that the peak-to-peak value of voltage developed across the input capacitance  $C$ , as the uncovered stator area varies from zero to  $A$ , is  $K_0 AE/C$ , where  $K_0$  is the permittivity of free space ( $8.84 \times 10^{-12}$  farads per meter),  $A$  is the total stator area ( $6.0 \times 10^{-3}$  square meters),  $C$  is the input capacitance ( $1.0 \times 10^{-20}$  farads), and  $E$  is the incident electric field intensity in volts per meter.

In the above relationship,  $K_0$  is a universal constant, while  $A$  and  $C$  are constants of a given instrument. Thus the peak-to-peak amplitude of the saw tooth voltage is  $5.31 \times 10^{-4}$  volts for a field of 1 volt per meter, and varies linearly with the applied electric field.

The peak value of the fundamental component of the above voltage is  $4/\pi^2$  of this value, and its frequency 500 cps. Thus, the fundamental component of the developed voltage is  $2.15 \times 10^{-4} E \sin 1,000 \pi t$ . Measured values of developed voltage are generally about 90 percent of the calculated value. The difference is probably due to fringing of the electric field around the rotor.

### Equipment

The electrostatic generating voltmeter head, connecting cable, and associated amplifier and power supply are shown in Fig. 2. The dynamotor furnishes plate voltages, and the 12-volt tubes are connected in series pairs to operate from a 24-volt battery. Battery current drain is about 4 amperes. Despite extremes in physical operating conditions of shock, acceleration and



# ARE THESE GATES '50 DECADE PRODUCTS MAKING MONEY FOR YOU?



1



2

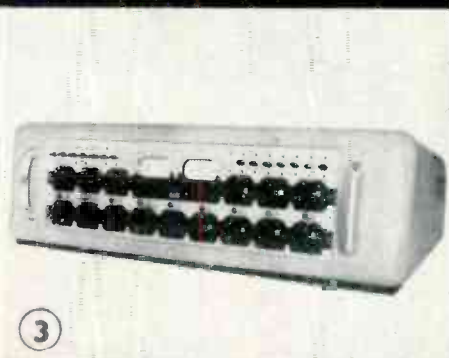

3

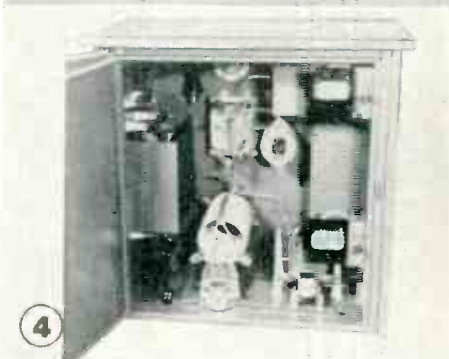

4

## GATES

  
**RADIO COMPANY**  
 QUINCY, ILLINOIS, U. S. A.



5



6



7



8

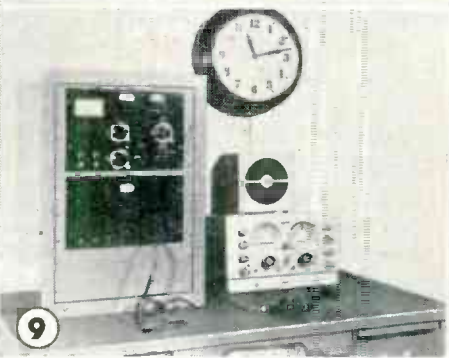

9

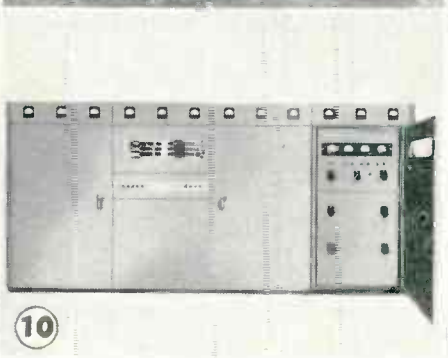

10

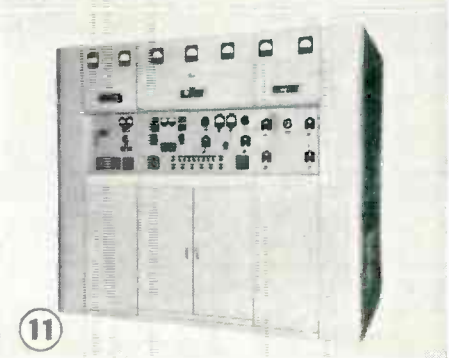

11

1. 52-CS Studioette Speech Console.
2. BC-1F Air-conditioned 1KW Broadcast Transmitter.
3. SA-50 Dual Channel Speech Console.

4. Gates Antenna Coupling Equipment.
5. Typical 4-Tower Centralized Phasing Cabinet.
6. HF5-10 High Frequency Phone and Telegraph Transmitter.

7. SA-40 Single Channel Speech Console on CB4 Control Desk.
8. GY-48 Complete 250-watt Radio Broadcasting Station.
9. 50-watt Telephone and Telegraph Communications Transmitter.

10. BC-5B 5KW Transmitter with Phasor.

11. HF-15 15,000-watt Telegraph Transmitter.

→ Quality **PLUS** makes **GATES** a **MUST** →

**Introducing**  
**THE NEW No. 5841**  
 Subminiature  
**CORONA REGULATOR**

★

**CHARACTERISTICS**

D.C. Starting Voltage.....(max.) 930 Volts  
 D.C. Regulating Voltage..... 900 ±15 Volts  
 Regulated Current Range..... 2-50  $\mu$ a  
 Voltage Regulation (2-50  $\mu$ a)...(max.) 1.5%  
 Life.....(min.) 1000 hrs.

**RATINGS**

Regulator Current.....(max.) 50  $\mu$ a  
 Relative Humidity.....(max.) 100%  
 Ambient Temperatures..... -65°C to 100°C.



The 5841 sub-miniature corona regulator now in production is another Victoreen component developed to make fine instrumentation finer. This regulator supplements other specially designed electron tubes required in radiation measurement and in the broader field of laboratory instruments.

... subminiature  
**ELECTRON TUBES**

Tube Type	Typical Service	Volts $E_{c1}$	Volts $E_{c2}$	Volts $E_b$	$\mu$ a $I_b$	$\mu$	$\mu$ hos $G_m$	Grid current Signal grid
*5800	** Elec-trometer Tetrode	+3.4	***-3	+4.5	12	1	15	$3 \times 10^{-15}$
*5803	Elec-trometer & D.C. Amp.	-1.7	----	+7.5	100	2.0	150	$10^{-14}$
*5828	D.C. Amp.	-1.0	----	45	250	17.5	450	$10^{-9}$

— — — and a complete line of counter tubes including the universally used 1B85, the 1B67 end window mica window tube, gamma ray counters, and sub-miniature counter tubes — — — not forgetting Victoreen hi-meg resistors vacuum sealed in glass, values 100—10,000,000 megohms.

Write for data sheets



**THE VICTOREEN INSTRUMENT CO.**  
**5806 HOUGH AVENUE CLEVELAND, OHIO**

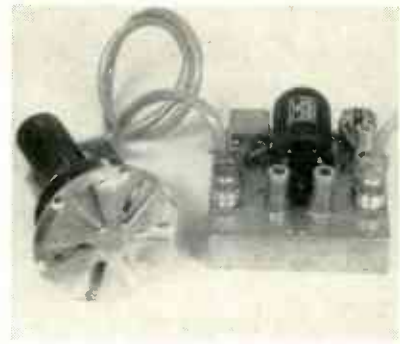

FIG. 2—Generating voltmeter head, amplifier and power supply weigh 17 pounds and require 100 watts from a 24-volt battery

vibration, there has been no evidence of malfunctioning of the generating voltmeters. On a recent flight, when a V-2 rocket reached a peak velocity in excess of 3,000 mph at an altitude of approximately 100,000 feet, two generating units were carried aloft, recovered upon completion of the flight, and subsequently reused.

The following requirements were fixed by limitations in telemetering facilities: (1) A dynamic range of 1 to 10,000 volts per meter had to be compressed to the telemetering voltage range of 0 to 5 volts. (2) Field changes had to be followed within 0.1 second.

Satisfaction of these requirements was obtained by use of the system shown in the block diagram, where the amplitude cathode follower provides an accurate indication of the larger field strengths, 50 to 10,000 volts per meter. The third amplifier, in conjunction with the commutator, operates as a synchronous amplifier. Either a positive or negative peak of amplified signal, depending on the polarity of the electric field, is momentarily switched to ground at the same instant each cycle, by the commutator. The a-c component of the resulting pulsating voltage is filtered by an R-C network at the grid of the polarity cathode follower. This circuit is a peak-reading voltmeter which gives a reliable measure of the amplitude of small fields from 1 to 50 volts per meter, and the polarity of any field strength greater than 1 volt per meter.

With the exceedingly wide dynamic range of the instrument as described, the absolute accuracies



# Announcing

## NEW MEMBER OF THE

# MYCALEX FAMILY

## 9 Pin Miniature Tube Sockets



Enlargement of the new 9 (NOVAL) pin miniature tube socket.

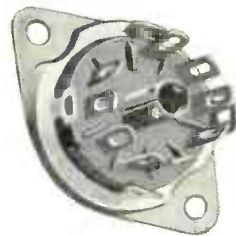

Above: Complete 9 pin miniature socket.  
Below: Precision moldings in MYCALEX actual size two views.

We are proud to announce the addition of a 9 pin (NOVAL) miniature tube socket to the MYCALEX line. It has all the electrical characteristics of the widely used MYCALEX 410 and 410 X 7 pin tube sockets and fully meets RMA standards.

The NOVAL is injection molded and produced in two qualities to satisfy different requirements.

Write us today and let us quote you prices on your particular requirements. We will send you samples and complete data sheets by return mail. Our engineers are at your disposal and would be glad to consult with you on your design problems.

### Mycalex Tube Socket Corporation

"Under Exclusive License of Mycalex Corporation of America"

30 Rockefeller Plaza, New York 20, N. Y.

MYCALEX 410 for applications requiring close dimensional tolerances. Insulation loss factor of .015 (at 1 MC) yet compares favorably in price with mica filled phenolics.

MYCALEX 410X for applications where general purpose bakelite was acceptable but with an insulation loss factor of only .083 (at 1 MC). Prices compare with lowest quality insulation materials.



## MYCALEX CORP. OF AMERICA

"Owners of 'MYCALEX' Patents"

Executive Offices: 30 Rockefeller Plaza, New York 20, N. Y.

Plant and General Offices: Clifton, N. J.

# HOT ASSIGNMENT

for this PROGRESSIVE fastener

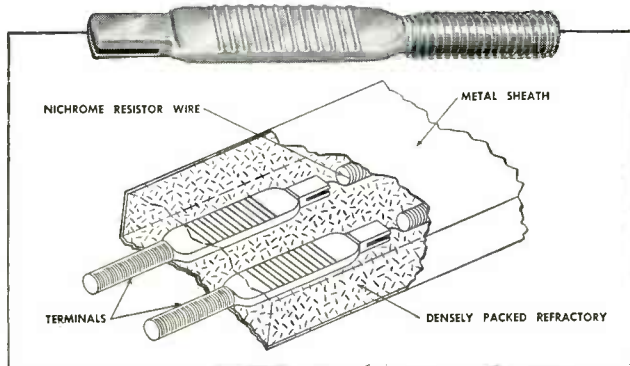

Edwin L. Wiegand Company uses this terminal pin on their versatile Chromalox seamless blade-type immersion heaters, which operate as high as 750°F. It is one of many special fasteners made by Progressive.

The design provides for electrical clearance between the pin and the metal heating blade casing — for secure fastening of the pin in the refractory — and for attaching electrical wiring connections.

Progressive is equipped to handle special fastener production with speed, precision and economy. Do what many leading manufacturers do — IF IT'S SPECIAL, see PROGRESSIVE.



WRITE FOR OUR CATALOG  
IT MAY SAVE YOU MONEY

## Other typical PROGRESSIVE "Specials"

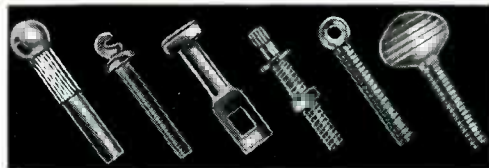

**THE PROGRESSIVE  
MANUFACTURING COMPANY**

50 NORWOOD ST., TORRINGTON, CONN.

SALES OFFICES: SAN FRANCISCO, LOS ANGELES,  
PORTLAND, DETROIT, PHILADELPHIA, CLEVELAND,  
SEATTLE, BOSTON, SYRACUSE, ST. LOUIS, CHICAGO.

obtainable may be of the order of 5 percent. However, for a restricted dynamic range application, with special attention paid to calibration, absolute accuracies of 1 percent should be readily obtainable.

## Aluminum Fins for Tubes

ALUMINUM radiators for high-power transmitting tubes were made feasible by an aluminum-to-steel molecular bonding process developed during the war. Previous designs failed because the fast oxidizing rate of aluminum rendered the soldering of aluminum directly to the copper anode impractical. Lightweight radiators of aluminum cut shipping costs and permit easier tube installation in the close quarters of a radio transmitter.

The new bonding process employs a hollow steel core that surrounds the copper anode, and is soldered easily to it. A muff of aluminum is cast and bonded to the steel. The 140 aluminum radiator fins are brazed to this muff, fanning out like a tissue-paper Christmas bell. The chemically bonded aluminum-to-steel junction offers no measurable resistance to the transfer of heat from the tube anode, and thus the advantages of the high conductivity of aluminum and an efficient fin design can be realized fully.

The difference in the expansion rates of the thick aluminum muff



This 25,000-watt Westinghouse radio transmitting tube with a laboratory-built aluminum radiator weighs 98 pounds, which is 56 percent less than conventional 225-pound copper-radiator tubes



# NEW INSTRUMENTS DEMONSTRATED

at the I.R.E. Show in  
New York City.

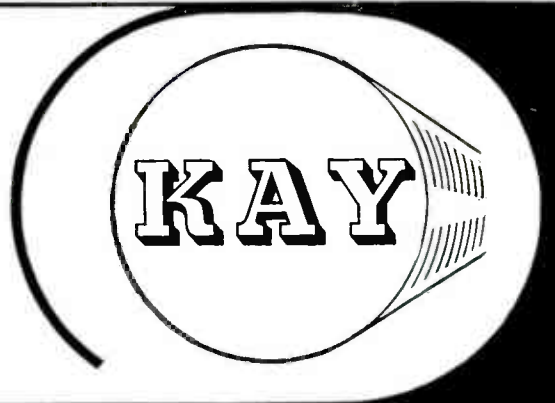

## THE DUAL MEGA-MARKER SR.

A Crystal-Controlled High Output TV RF Marker Generator Provides both sound and picture RF markers on each TV channel. Crystal Controlled 4.5 mc signal also available. Output Attenuators on RF and 4.5 mc signals. Carrier Frequency Accuracy 0.01% for Picture. Carrier Separation 4.5 mc  $\pm$ 500 cps. Price: \$350.00.



## WIDE BAND ATTENUATORS



Models 20 and 21  
Frequency Range—D.C. to 500 mc.  
Attenuation Steps—20, 10, 5, 3, 2, 1 DB: Fixed Insertion Loss 10 DB.  
Terminal Impedances: Model 20:50 ohms, Model 21:70 ohms.  
VSWR at Terminals—Very Low  
Attenuation Accuracy—0.1 DB/DB Loss at 500 mc. Better Accuracies at Low Frequencies.  
Price: \$50.00

## THE MICROWAVE MEGA-NODE

Random Noise Sources Covering Frequency Range 3000-12,500 mc.  
Available in Five Wave Guide Sizes—RG 48/U, 49/U, 50/U, 51/U, 52/U. Noise Power Available up to 16 db above "Johnson" Noise. Useful for Measuring Noise Figures—Effective Bandwidth and Receiver Gain  
Price: Standard Unit One Waveguide and Power Supply \$295.00  
Standard Unit plus two Extra Waveguides \$600.00



## THE MEGA-PIX



A 12 Channel Crystal Controlled TV Generator Useful for Final Air Check of Receivers on All Channels. Provides Both Carriers with Adjustable internal FM Sound Modulation and Adjustable Video Modulation from External Source. Carrier Frequency Accuracy—0.01% for Picture—Carrier Separation 4.5 Mc  $\pm$ 500 cps.  
Price: \$990.00.

## OTHER NEW INSTRUMENTS

### AUDIO

The SONACTOR—a speech pitch extractor

### AUDIO

The SONA-STRETCHER—A phonetic method of slowing down speech without altering frequency content.

### INDUSTRIAL

The ROTALYZER — An indicator of instantaneous rotational speed vs. time.

Write for complete catalog

All Prices F.O.B.

Factory 10% Higher Outside USA and Canada

ELECTRIC

KAY

COMPANY

25 Maple Avenue

Pine Brook, N. J.

Phone CAldwell 6-4000

# Here's What it Takes —

TO MAKE A  
CLOSE TOLERANCE,  
HIGH QUALITY CRYSTAL



- ✓ The **BEST** Research and Engineering
- ✓ The **BEST** Manufacturing Facilities
- ✓ The **BEST** Production "Know How"
- ✓ The **BEST** Testing Equipment

AND these are the reasons why Reeves-Hoffman Crystals are specified for—Government Uses, Television, Mobile Radio, Aircraft and Commercial Radio, Marine Radio, Test Equipment and Special Purpose Equipment.

Remember—"There's No Substitute For Quality." For the Crystal units you need insist on the best . . . call on Reeves-Hoffman.

**REEVES**  **HOFFMAN**  
**C O R P O R A T I O N**

Cherry and North Streets • Carlisle, Penna.  
Offices: NEW YORK • BALTIMORE • BUFFALO • CHICAGO • KANSAS CITY

and the thin steel core would ordinarily cause failure of the aluminum-to-steel bond. To prevent this, the aluminum muff is cooled in such a way as to pre-load the steel in compression so that the bond can withstand the severe thermal cycles experienced in normal use.

Additional field tests are necessary before aluminum radiator tubes can be made commercially available.

## Voice-Operated Busy Signal

CERTAIN special types of telephone networks use voice calling over a single speaker for a multiplicity of lines. The circuit shown in Fig. 1 enables the party at the called end to identify the particular line on which the voice call is being heard. The system is voice operated, and its sensitivity is such that low-level talking will light an appropriate lamp, but noise will not.

Since voice talking levels rarely exceed + 10 vu (10 milliwatts), and are often as low as - 30 vu (1 microwatt), an amplifier is required; and since line noise will also be amplified, some kind of frequency discrimination is required to prevent false operation. Another design factor is adjustment of release delay time, so that the busy signal will not flash between words or short pauses.

Input resistors  $R_1$  and  $R_2$  assist in providing high input impedance so that the transmission loss caused by bridging the busy signal across the line is small. With no input signal  $V_2$  is biased almost to cutoff by the voltage drop across  $R_3$ , and the relay is non-operated. When speech appears on the line, it is amplified by  $V_1$  and  $V_2$ . The output signal current of  $V_2$  flows mostly

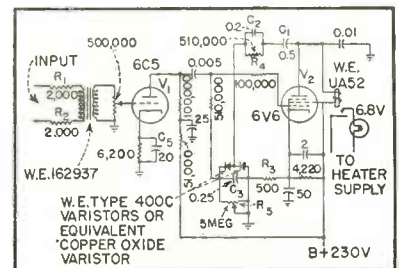

FIG. 1—Voice-operated busy signal operates on low-level speech, but ignores line noise



*Now!*  
**Get extra quality—  
 without extra cost—  
 in wire-wound  
 components!**

→ When you specify I-T-E for wire-wound products, you get components specially designed to meet the exacting and changing needs of the electronics industry. And all I-T-E units are engineered for extra quality—given the same thought in design, the same care in fabrication that the most complicated I-T-E Switchgear devices receive!

CHECK YOUR NEEDS AGAINST THIS LIST:

### I-T-E FOCUS COILS

Available in two types: The first utilizes an electro-magnet; the second combines a permanent magnet with an adjustable electro-magnet. I-T-E Focus Coils are made for use with tubes 10", 12", and 16" in size. Information required to manufacture: Type of tube; second anode voltage; focusing current; types of mountings and leads desired.



### I-T-E DEFLECTION YOKES

I-T-E Deflection Yokes are built to have uniform characteristics. During manufacture, wire size and quality are checked constantly. Coils are impregnated with a special moisture-resistant thermo-plastic material which has been properly cured to insure a firm coil with a minimum of losses. Deflection Yokes can be had with wire leads, resistors, and capacitors made to your specifications.



### I-T-E "METCLADS" (Metal-Clad Resistors)

Made of highest-grade resistance wire, wound on a special heat-resistant bakelite strip, and insulated by special phenolic coating. The resistance element is completely enclosed in a metal case of either brass- or zinc-plated steel. Brass terminals are securely anchored to the bakelite base strip and are tinned for easy soldering. I-T-E "Metclads" are available in lengths from 2" to 12"; in wattages from 7 to 42. Mountings can be made to your specifications.

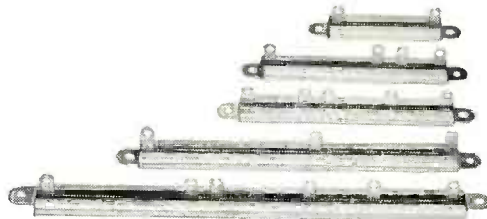

### I-T-E ENAMELED RESISTORS



STANDARD FIXED RESISTORS  
 from 5 to 200 Watts

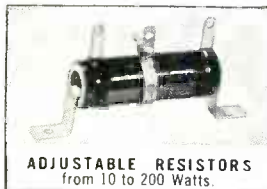

ADJUSTABLE RESISTORS  
 from 10 to 200 Watts

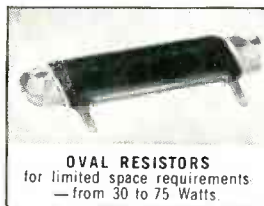

OVAL RESISTORS  
 for limited space requirements  
 — from 30 to 75 Watts

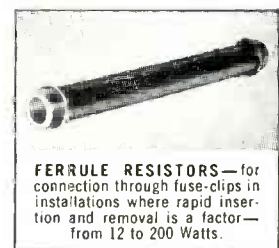

FERRULE RESISTORS—for  
 connection through fuse-clips in  
 installations where rapid inser-  
 tion and removal is a factor—  
 from 12 to 200 Watts



For complete information on any I-T-E wire-wound products, write, specifying your needs.

## RESISTOR DIVISION

I-T-E Circuit Breaker Company  
 19th & Hamilton Streets, Philadelphia 30, Pa.

I-T-E Wire-Wound Products: RESISTORS • DEFLECTION YOKES • FOCUS COILS • SPECIAL PRODUCTS

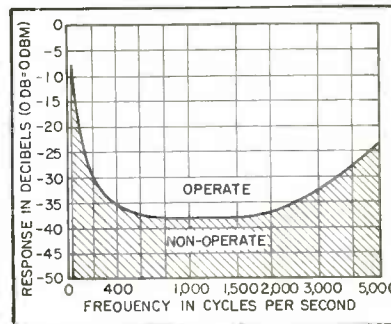

FIG. 2—Frequency response of the voice-operated busy signal

through the combination of  $C_1$ ,  $C_2$ , and  $R_1$ , since the relay winding has a very high impedance. The signal is rectified by the copper-oxide varistors and appears as a positive charge on the left side of  $C_3$ . This charge drives the control grid positive and the resultant increase in plate current operates the relay whose contacts are used to control a lamp or other indicator.

When speech ceases, the charge across  $C_3$  will leak off to ground through the back resistance of the rectifiers and  $R_5$ . When the plate current has decreased to the value of current at which the relay releases, the lamp or indicator is extinguished.

The release or holdover time of the relay is governed by the rate of discharge of  $C_3$ , which depends primarily on  $R_5$  and the back resistance of the rectifiers. By adjusting  $R_5$ , the release time may be varied from approximately three to ten seconds.

Discrimination between noise and signal is obtained by frequency weighting. This is accomplished in the voice-operated busy signal circuit by attenuating the frequencies below about 300 cycles in the input transformer, and by attenuating frequencies above about 3,000 cycles by by-passing them to ground through a 0.01- $\mu$ f capacitor. The input transformer is wound on the core of a G-type relay, and has a sufficiently low mutual inductance to suppress the low frequencies and yet have a satisfactory response in the middle voice-frequency range. The frequency response of the voice-operated busy signal is illustrated in Fig. 2.

The circuit described was developed by the Bell Telephone Laboratories for use by the Interstate

specify



AVOID LOSSES FROM  
**"BLOBBING"**  
 Not being an extruded plastic,  
 it eliminates the costly  
 "blobbing" of insulations under  
 heat of soldering irons

# "NOFLAME-COR"

the TELEVISION hookup wire

APPROVED BY  
 UNDERWRITERS  
 LABORATORIES AT

**90°** CENTIGRADE **600** VOLTS

Proven BEST, and specified regularly, by leading manufacturers of television, F-M, quality radio and all exacting electronic equipment. For maximum output and minimum rejects. Available in all sizes, solid and stranded. Over 200 color combinations.

PRODUCTION ENGINEERS: Specify "NOFLAME-COR" for absolute uniformity of diameter, permitting clean stripping of insulation without damage to the copper conductor...

NO NICKING OF CONDUCTORS  
NO CONSTANT RESETTING OF BLADES

RUBBER	75°
PLASTIC	80°
<b>"NOFLAME-COR"</b>	<b>90°</b>

- Flame Resistant
- High Insulation Resistance
- Heat Resistant
- Facilitates Positive Soldering
- High Dielectric
- Easy Stripping
- Also unaffected by the heat of impregnation — therefore, ideal for coil and transformer leads

COMPLETE DATA AND SAMPLES ON REQUEST

*"made by engineers for engineers"*

## CORNISH WIRE COMPANY, Inc.

605 North Michigan Avenue,  
 Chicago 11

15 Park Row, New York 7, N. Y.

1237 Public Ledger Bldg.,  
 Philadelphia 6

MANUFACTURERS OF QUALITY WIRES AND CABLES FOR THE ELECTRICAL AND ELECTRONIC INDUSTRIES



# 10 Times More Rugged-

*New Sylvania shock-tested tubes withstand shocks greater than 400 G's*

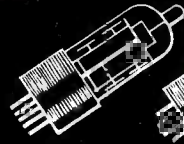
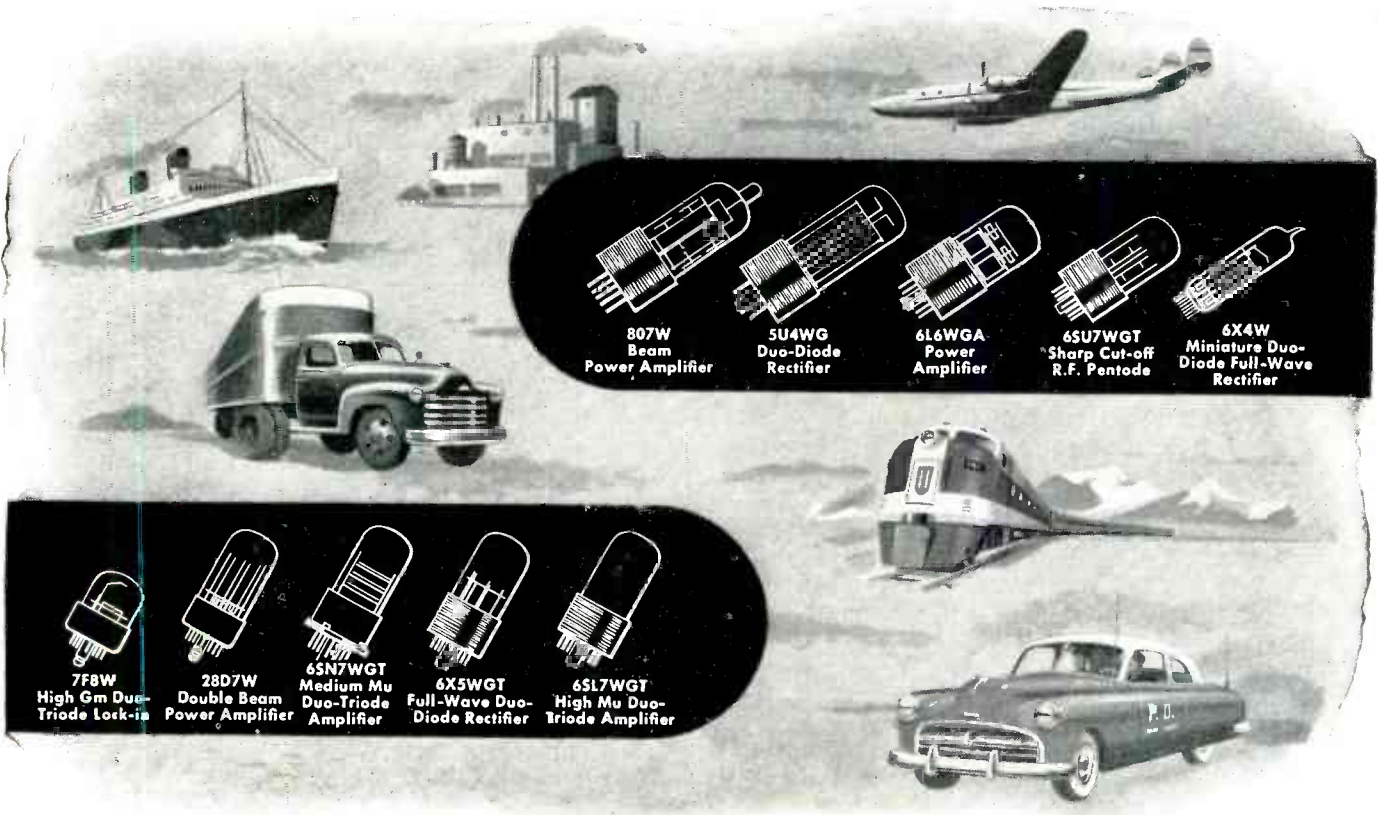

**807W**  
Beam  
Power Amplifier

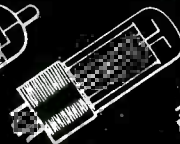

**5U4WG**  
Duo-Diode  
Rectifier

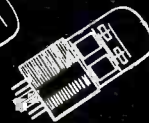

**6L6WGA**  
Power  
Amplifier



**6SU7WGT**  
Sharp Cut-off  
R.F. Pentode



**6X4W**  
Miniature Duo-  
Diode Full-Wave  
Rectifier



**7F8W**  
High Gm Duo-  
Triode Lock-in



**28D7W**  
Double Beam  
Power Amplifier



**6SN7WGT**  
Medium Mu  
Duo-Triode  
Amplifier



**6X5WGT**  
Full-Wave Duo-  
Diode Rectifier



**6SL7WGT**  
High Mu Duo-  
Triode Amplifier

**Ideal for industrial radio applications...  
for aircraft...buses...trains...police cars...  
or wherever shock and vibration are problems**

Troublesome problems of tube failure resulting from shock or heavy vibration are now being solved... for keeps... by these new Sylvania "Ruggedized" or "W" tubes. Originally designed to government specifications to withstand shock and vibration caused by artillery action, these tubes keep operating under vibration up to 2-1/2 G's... withstand shocks more than 400 times the force of gravity.

A dozen new design techniques have gone into the perfection of these tubes. More than that, they are precision-built from

precision parts. Exhaustive lab and field tests have definitely proved them as much as 10 times more rugged than ordinary tubes. Electrical characteristics are similar to those of standard types.

Note too, their reduced overall length and their straight glass bulbs... features which make possible smaller and more compact equipment design.

Maximum ratings and other characteristics of these new "Ruggedized" types are available from Sylvania Electric Products Inc., Dept. R2104, Emporium, Pa.

**✓ CHECK THESE 10  
"RUGGEDIZED" FEATURES  
for longer life and  
better performance**

1. Double thickness micas
2. Heavier side-rod supports
3. Shorter leads
4. Straight glass bulb
5. Flat, circular header
6. Fewer internal connectors
7. Shorter elements
8. Reduced overall height
9. Additional mount supports
10. Low-loss phenolic base

# SYLVANIA ELECTRIC

RADIO TUBES; CATHODE RAY TUBES; ELECTRONIC DEVICES; FLUORESCENT LAMPS, FIXTURES, SIGN TUBING, WIRING DEVICES; LIGHT BULBS; PHOTOLAMPS

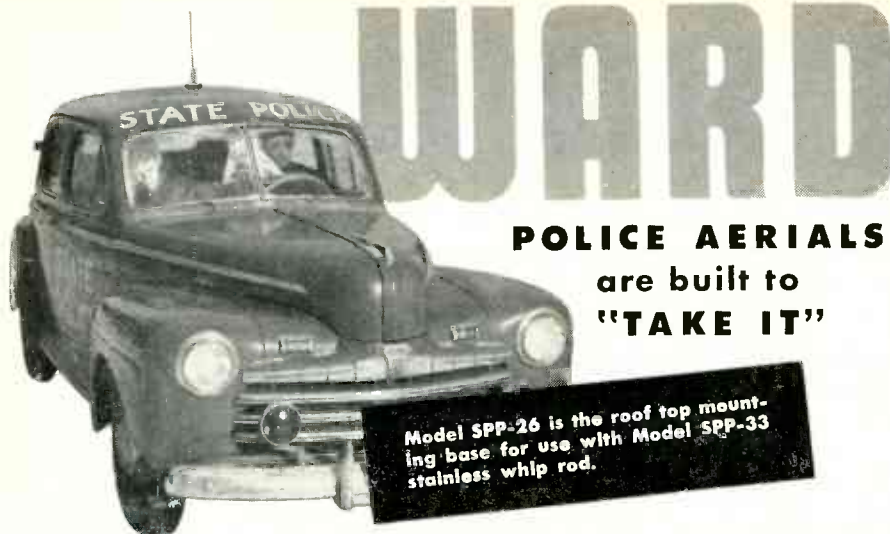

## POLICE AERIALS are built to "TAKE IT"

Model SPP-26 is the roof top mounting base for use with Model SPP-33 stainless whip rod.

Day in and day out operation on a 24-hour schedule of mobile 2-way police radio demands equipment that can stand the most rigorous conditions.

It is no mere coincidence that *more police and state highway patrol cars and motorcycles are equipped with Ward aerials than with any other kind.* Police officials know that Ward aerials always give maximum performance.

Scientifically designed Ward aerials are made of a special alloy to resist corrosive atmospheric conditions such as ice, snow, sleet, rain, and fog, because police vehicles must work a 24 hour-a-day schedule, 365 days a year.



For motorcycle use, the durable 42 inch whip rod is mounted in a heavy rubber shock mounting base. It is available in two styles—Model SPP-6 with Ring Tip or Model SPP-6A with Ball Tip.

**WARD PRODUCTS CORPORATION**  
1523 E. 45TH STREET, CLEVELAND, OHIO  
Division of the Gabriel Company

*Ward is the largest and oldest exclusive maker of auto radio and television aerials.*

## Another chapter in the "SUCCESS STORY OF THE MAGIC WAND ANTENNAS"

Ward Model TVS-59 was especially designed to provide better reception in fringe areas. Comparative tests with the best competitive antennas of this type prove that the new Ward TVS-59 *outperforms all others on all channels.* Write for our free booklet, "The Story of the Magic Wand." It contains interesting, authoritative information about TV and FM antennas.

**WARD PRODUCTS CORPORATION**  
1523 E. 45th STREET, CLEVELAND, OHIO  
Division of the Gabriel Company

*Ward is World's largest manufacturer of antennas for radio and television*

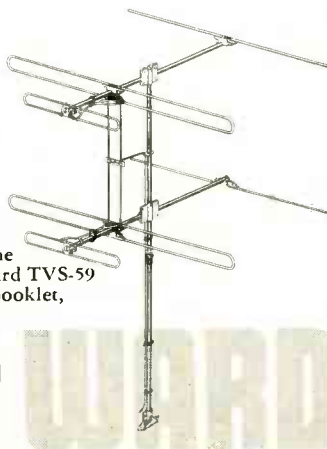

Airways Communications Stations of the CAA. It is presented in somewhat more detail in the Bell Laboratories Record for December, 1949, by E. C. Borman.

## SURVEY OF NEW TECHNIQUES

CATHODIC VACUUM ETCHING, developed by Ford Motor Co., involves placing the metal sample in a partial vacuum with argon and



applying 12,000 volts between the sample and an upper electrode. Resulting argon ions bombard the surface of the sample and knock off minute particles in such a way that flow lines can be examined under a microscope. These indicate direction of metal flow during forging, with detail not hitherto possible with chemical etching.

GLASS-ENCASED RESISTORS for d-c amplifiers and G-M circuits can be made essentially independent of humidity in values up to  $10^{12}$  ohms by cleaning the surfaces first with carbon tetrachloride, baking for several hours at 120 C and varnishing with GE varnish No. 9978. Details are given in an AEC report, "An Investigation of the Properties of High-Valued Resistors and Methods of Reducing Surface Leakage", now declassified and available at 10 cents from Technical Information Branch, Oak Ridge, Tenn. The technique was also successful on steatite and porcelain when higher temperatures and longer baking times were used.



# COPPER ALLOY BULLETIN

REPORTING NEWS AND TECHNICAL DEVELOPMENTS OF COPPER AND COPPER-BASE ALLOYS

Prepared Each Month by BRIDGEPORT BRASS COMPANY "Bridgeport" Headquarters for BRASS, BRONZE and COPPER

## Strong, Durable Wire Splice Uses Duronze III Jaws

Automatic electrical line splices, applied without solder, screw driver or wrench, reduce installation costs for outside overhead wiring jobs. Illustrated is the latest type made by Fargo Mfg. Co., Poughkeepsie, New York. Through copper-base alloys these units are corrosion resistant, and the splice is as strong as the conductor itself, and electrical conductivity is greater.

### Hard, Strong Material For Jaws

The stripped wire is merely pushed into the ends of the splice forcing the jaws of the chucks to open as they move back on the taper. The spring between the chucks keeps the teeth of

the taper, bores the recess and cuts off the part. The thread is cut on a tapping machine and the slots are milled in a hand miller after the four expansion holes are drilled.

On a dial feed press, a brass disc which acts as a stop to keep the wire from entering too deeply, is inserted in the counterbore and secured by turning the edges over in a die.

### Hard Drawn Copper Tubing; Phosphor Bronze Spring

The body or outer shell, which has an inside taper to correspond to the taper on the chuck, is made of hard-drawn copper tubing for its high elec-

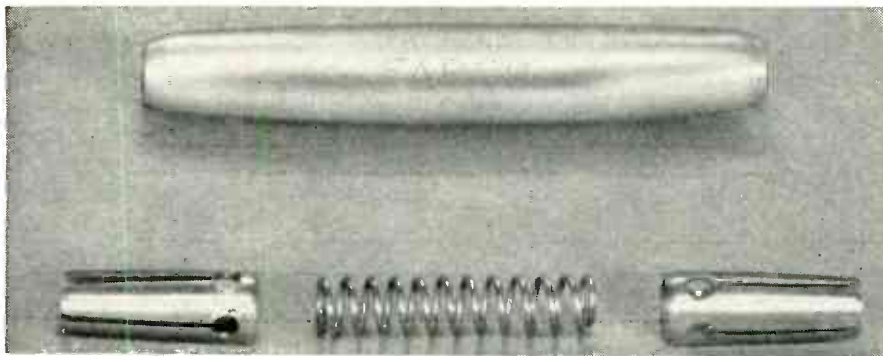

Automatic line splicer with internal parts—two Duronze III jaws with phosphor bronze separator spring. Courtesy Fargo Mfg. Co., Poughkeepsie, N. Y.

the collet type jaws in contact with the wire until they obtain a good grip. From that point on, the greater the tension, the tighter the jaws grip.

Since the chuck takes the brunt of the load, its jaws must be made from a strong, hard alloy as they are the vital elements of the connector. Duronze III, aluminum silicon bronze, answers this requirement exceptionally well. In the annealed condition it has the remarkably high tensile strength of 90,000 pounds per square inch, and a Rockwell hardness of B85.

The jaws are made from round rod on a screw machine which drills, forms

trical conductivity, excellent corrosion resistance and adequate strength. Since the spring, which holds the chucks against the shell tapers until the wire is engaged, is under constant compression and may be subject to deterioration from the elements, phosphor bronze has been chosen for maximum reliability and its high corrosion resistance.

Bridgeport's long experience in making high strength, corrosion resisting copper-base alloys containing various amounts of tin, silicon, aluminum, cadmium, phosphorus, arsenic, etc., is available for products that must meet modern high engineering standards.



## Did You Know... That Bridgeport Brass Once Made Coal Oil Lamps?

Although Bridgeport Brass is not anxious to claim the doubtful honor of being the maker of the oil lantern that Mrs. O'Leary's cow kicked over to start the 1871 Chicago fire, there is a possibility that Bridgeport's "Farmer Model" may have been the offender.

In 1859, six years before Bridgeport Brass was founded, the famous Drake Well at Oil Creek, Pennsylvania was brought in. This inaugurated the Age of Petroleum. Although it took some little time to swing over from candles and chimneyless lard oil and whale oil lamps, America took on a brighter outlook as more and more Bridgeport's Lincoln and National kerosene lamp burners invaded the homes. This was followed by Bridgeport Leader student lamps and finally by the famed Rochester lamps with the tubular wick and petticoat lamp shade.

With the advent of electric illumination, Bridgeport gave up the manufacture of kerosene burners and lamps and discarded the tools for making them. Today, these tools would have been invaluable to produce "genuine antique reproductions" of brass student lamps and Rochester lamps which gladden the hearts of home decorators.

BRASS • BRONZE • COPPER • DURONZE — STRIP • ROD • WIRE • TUBING

MILLS IN  
BRIDGEPORT, CONNECTICUT  
INDIANAPOLIS, INDIANA

In Canada:  
Noranda Copper and Brass Limited,  
Montreal



BRIDGEPORT BRASS COMPANY  
BRIDGEPORT 2, CONNECTICUT

Established 1865  
District Offices and Warehouses in Principal Cities

here's your answer to problems in

## OSCILLOSCOPE RECORDING!



### FAIRCHILD *Oscillo-Record* CAMERA

This new engineering tool is finding more and more use in—

1. Recording of electronic circuit performance.
2. Comparison of performance after changes have been made.
3. Study of complex high-frequency signals.
4. Comparison of two or more simultaneous phenomena.
5. Telemetering.
6. Analysis of high-speed transients.
7. Monitoring of random transients.
8. Maintenance of laboratory records.

A remote control connection plus dynamic braking makes it possible to start and stop the camera automatically by the signal itself, thereby making a complete record of irregularly occurring phenomena without wasting film and without any attention on the part of the operator. Other features include:

a) Sharp, clearly defined images on inexpensive 35mm film or paper; b) writing speeds up to 270 inches per microsecond; 20 seconds to 20 hours of recording on 100-ft. rolls of film, or 3½ minutes to 8½ days of recording on 1000-ft. rolls; d) no obstruction of oscilloscope controls; e) permits viewing of 'scope while photographing phenomena.

The Oscillo-Record Camera, designed by Fairchild in close cooperation with leading users and manufacturers of cathode-ray oscilloscopes, is the product of the world's foremost manufacturer of precision specialty camera equipment. It can be adapted to practically all 3-in. and 5-in. oscilloscopes.

Complete details may be obtained by writing to Dept. WS, Fairchild Camera and Instrument Corporation, 88-06 Van Wyck Boulevard, Jamaica 1, N. Y.



### NEW PRODUCTS

(continued from p 126)

meters is read on the range selector and the coefficient is read on the dial gage. It operates on any 110-volt, 60-cycle line.



#### Small Boat Radar

RAYTHEON MFG. CO., Waltham, Mass. The Mariners Pathfinder Jr. is a marine radar system specially designed for small craft. It operates on a wavelength of 3.2 centimeters. Minimum range is 75 yards and maximum, 20 miles. Range accuracy is within 2 percent and bearing accuracy is within 2 degrees. It is available for vessels equipped with 32-volt d-c, 110-volt d-c, 220-volt d-c or 115-volt a-c power systems. Power consumption in all cases is less than 750 watts.



#### Portable Radiation Detector

GENERAL ELECTRIC Co., Schenectady 5, N. Y., has announced a



**ANOTHER  
WESTINGHOUSE  
FIRST  
•  
ULTRA HIGH  
FREQUENCY**

# **STABILITY**

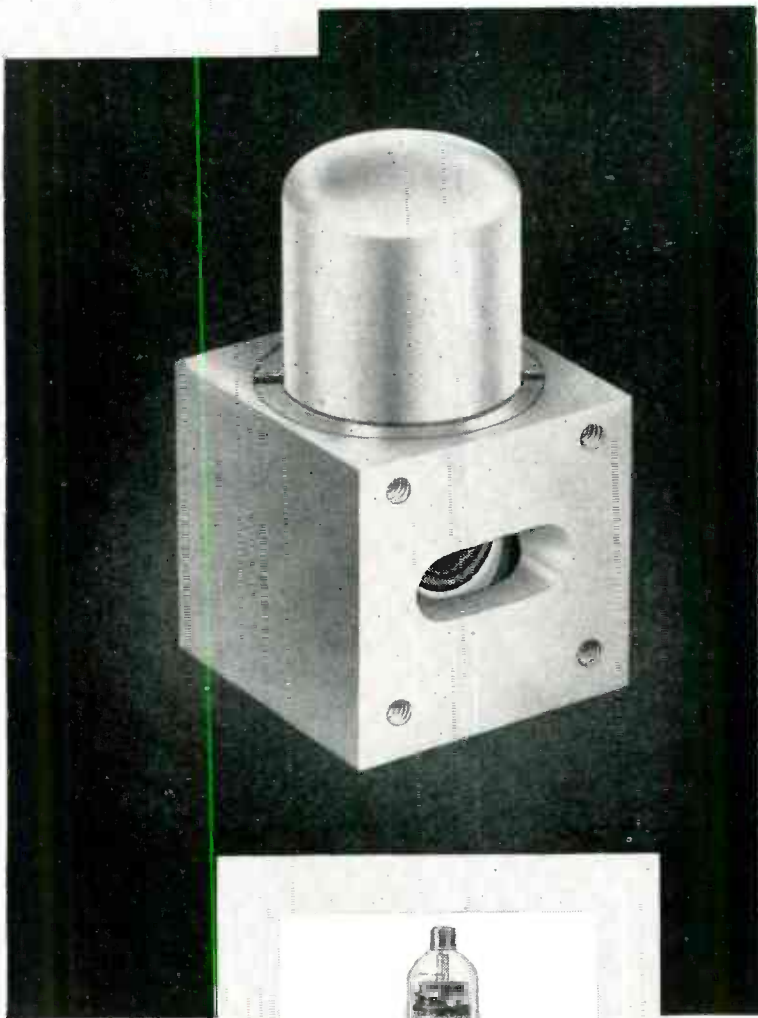

## **WESTINGHOUSE BEACON CAVITY 1Q SERIES GIVES TOP UHF CONTROL**

Typical of the leadership of Westinghouse Laboratories in the field of electronics is the performance of these new Reference Cavity tubes. Operating above 9000 megacycles, the frequency shift of this master control unit is maintained at less than *.5 of a megacycle* in the most extreme conditions of temperature, barometric pressure and vibration shock. Its outstanding precision and stability places it alone in the field of ultra high frequency control.

The research which is built into Westinghouse electronic products is your assurance of top performance for the job to be done—whether it be the latest advances in microwave techniques or the designing experience needed to meet extraordinary conditions of service and hard usage.

Write for information about the *complete* line of Westinghouse Tubes: Lamp Division, Westinghouse Elec. Corp., Bloomfield, N. J.



For many control applications, as in Resistance Welding, sturdy durability is a major requirement. With the WL-5796 Gas Thyratron, Westinghouse has engineered *more* ruggedness into a *smaller* tube—a development in space-saving and increased dependability.

**YOU CAN BE SURE...IF IT'S  
Westinghouse**

new portable radiation detector, the long-probe gamma survey meter, for measuring radioactivity from a distance. A detector located at the tip of a four-foot-long probe converts radioactive emanations into electrical energy. This detector consists of an electronic tube and a phosphor, and is powered by 1,000 volts induced from low-voltage batteries enclosed in a box that can be carried over the operator's shoulder.

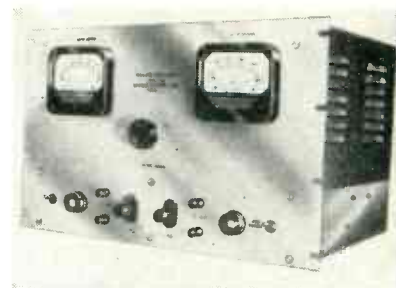

### Regulated Power Supply

CHATHAM ELECTRONICS CORP., 475 Washington St., Newark 2, N. J. Model EA-50A regulated power supply is a laboratory source of d-c power. It is continuously variable in output voltages from 0 to 500 volts. Ripple is less than 10 mv. Power input is 105 to 125 volts, 60 cycles. Regulation is 1 percent between 30 and 500 v, 2 percent between 10 and 30 v.



### Recorder Pen

BROWN INSTRUMENTS DIVISION, MINNEAPOLIS-HONEYWELL REGULATOR CO., Minneapolis, Minn. A solenoid-actuated pen which avoids ink-



FOR INDUSTRIAL RESEARCH  
FOR ECONOMIC PRODUCTION

## THE HYPERVAC 100

### Dean of Mechanical Pumps

produces extremely high vacuum at high speeds. It is the highest capacity pump of its kind that reaches an ultimate vacuum of better than 0.1 micron, often 0.02 micron of mercury. At 1 micron, the speed is 11 liters per second.

Here is a unit that backs diffusion pumps, or for purposes within the range of 0.1 micron performs reliably without a second stage. Applicable to evacuating vacuum spectrographs, lens and mirror coating, vacuum furnaces, etc. Quiet operation and long service are assured.

Write Dept. B. I for Engineering Bulletin 10B describing Cenco High Vacuum Pumps, Gages and accessory equipment, including prices.

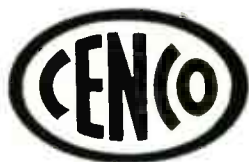

## CENTRAL SCIENTIFIC COMPANY

*Scientific Apparatus • Instruments • Chemicals*

Main Office and Plant • 1700 Irving Park Road • Chicago 13, Illinois

### BRANCHES

79 Amherst Street  
Cambridge 42, Boston, Mass.

441 Clinton Avenue  
Newark 8, New Jersey

146 Kendal Avenue  
Toronto 4, Ontario

7275 St. Urbain Street  
Montreal 14, Quebec



Presenting...

New Additions to the

**Seleton**

SELETRON RECTIFIER

Family



Joining the More than  
2,000,000 in Service  
in Radio and Television!

Designed Especially for Power and Bias Supplies  
in TELEVISION

MODEL NO.	PLATE SIZE	STACK THICKNESS	MAX. INPUT VOLTAGE R.M.S.	MAX. PEAK INVERSE VOLTAGE	MAX. D.C. OUTPUT CURRENT
1M1	1" sq.	3/8"	25	75	100 MA
8Y1	1 1/2" sq.	1 1/8"	130	380	20 MA
16Y1	1 1/2" sq.	1"	260	760	20 MA
5M4	1" sq.	1 1/8"	130	380	75 MA
5M1	1" sq.	7/8"	130	380	100 MA
5P1	1 1/8" sq.	7/8"	130	380	150 MA
6P2	1 1/8" sq.	1 1/8"	156	456	150 MA
5R1	1 1/2" x 1 1/4"	7/8"	130	380	200 MA
5Q1	1 1/2" sq.	1 1/8"	130	380	250 MA
6Q1	1 1/2" sq.	1 1/8"	156	456	250 MA
6Q2	1 1/2" sq.	1 3/8"	156	456	250 MA
5QS1	1 1/2" x 2"	1 1/8"	130	380	350 MA
6QS2	1 1/2" x 2"	1 3/8"	156	456	350 MA
5S1	2" sq.	1 1/8"	130	380	500 MA
6S2	2" sq.	1 3/8"	156	456	500 MA

SELETRON Selenium Rectifier miniatures have long been widely used with complete satisfaction by manufacturers in the Radio, Television and Electronics industries for receivers and other equipment.

Now SELETRON brings you these two new models ideally suitable in size and rating: No. 5S1 at 500 Mils—No. 8Y1, the "baby" of them all, measuring only 1/2" square and rated at 20 Mils, 130 volts. While these rectifiers are designed to meet television needs, engineers will find many applications for them in other electronic circuits. Other bias type rectifiers rated up to 250 volts will also be available.

A new leaflet on Bias Type 8Y1, describing its circuit possibilities is available. For your copy, write Dept. ES-28.

**RR SELETRON DIVISION RR**  
**RADIO RECEPTOR COMPANY, INC.**  
Since 1922 in Radio and Electronics

Sales Department: 251 West 19th St., New York 11, N. Y.

Factory: 84 North 9th St., Brooklyn 11, N. Y.

## The case of the Troublesome Coils

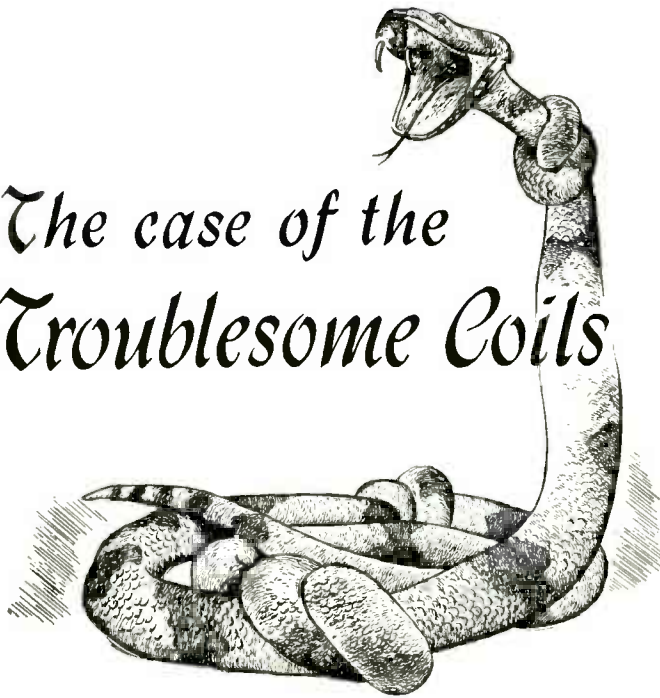

### A True Detective Story

**THE VICTIM:** A concern whose product is handled in large measure by automatic vending machines which refused to vend with regularity.

**THE VILLAINS:** Coil windings which apparently met original specifications but broke down in service.

**THE REMEDY:** New coil windings, designed and wound by Coto-Coil, with special insulation to withstand humidity, low temperatures and difficult working conditions.

**CASE CLOSED:** No more trouble. With the new coils, the vending machines resumed uninterrupted vending.

### WE ARE SPECIALISTS

For 32 years we have produced nothing but coils, designing and winding them for leading manufacturers. If you are troubled by coil failure, send us your specifications. We can serve you well.

**COTO-COIL CO., INC.**



COIL SPECIALISTS SINCE 1917

65 PAVILION AVE.  
PROVIDENCE 5, R.I.

throwing while providing speedy recording has been developed for use on circular chart electronic potentiometers. The V-type pen uses an amplifying linkage designed so that the solenoid's high velocity reaction is almost spent before the pen is picked up and moved. It is used for such applications as thermal limit recording in continuous pasteurizing processes and for temperature measurements on tire presses or rubber curing and plastic molding.

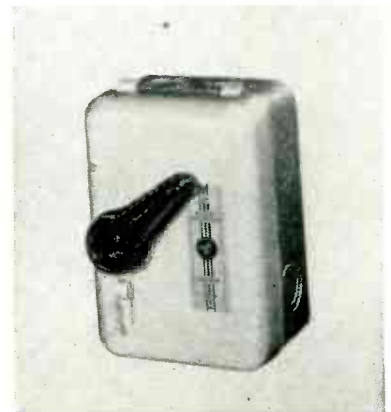

### Motor Controller

HEINEMANN ELECTRIC Co., Trenton, N. J., has announced a manual motor controller and enclosed general-purpose circuit breaker which is fully magnetic in operation. It is available in single, two and three-pole construction. Maximum ratings are: 50 amperes, 250 volts, a-c; 7.5 h-p, single phase, 60 cycles; 10 h-p, three phase, 60 cycles; 5,000-ampere interrupting capacity.



### Variable Transformers

THE SUPERIOR ELECTRIC Co., Hannon Ave., Bristol, Conn., announces



# Announcing the **NEW** Magnecorder

## PT7

### NOW ALL 3!

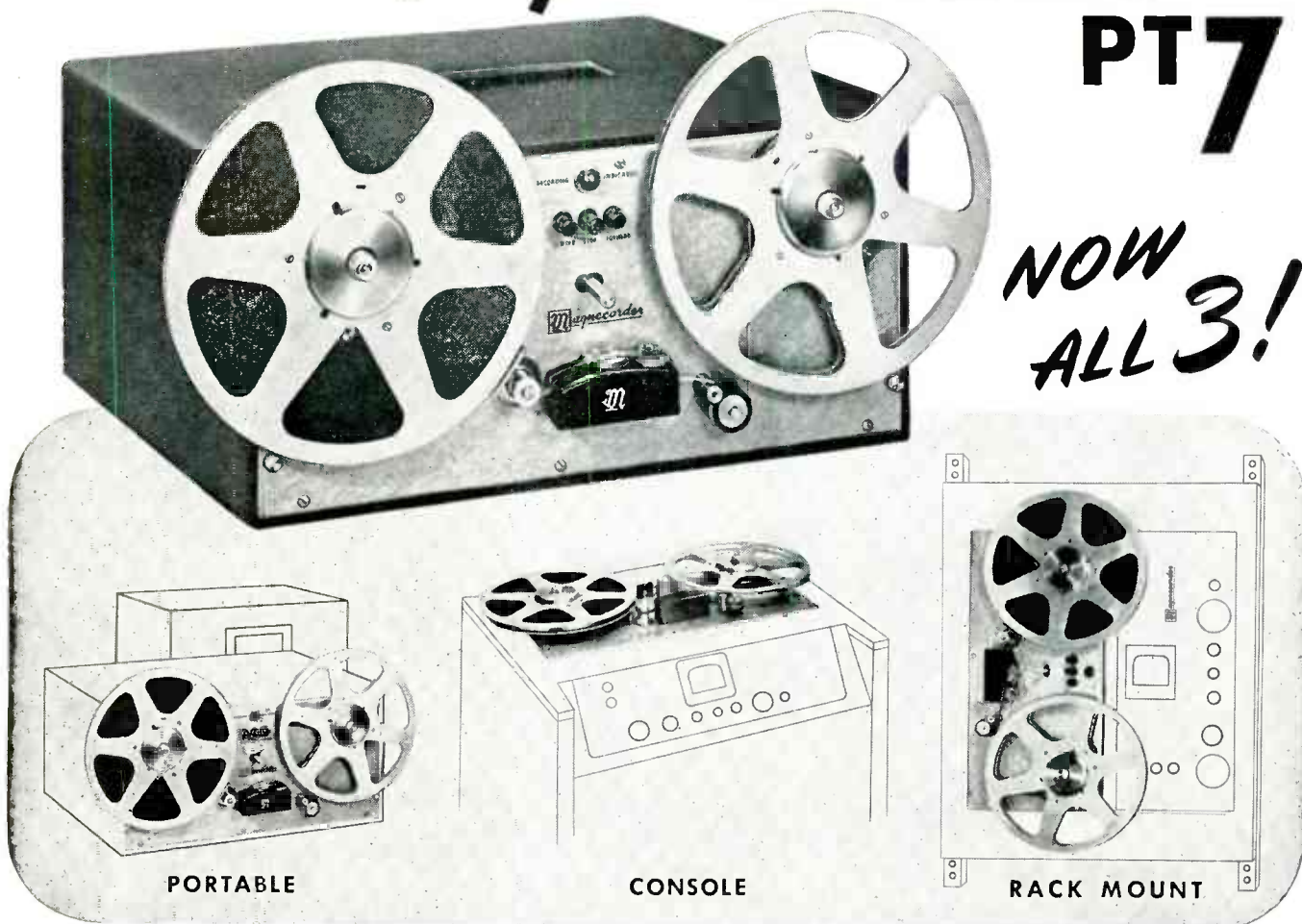

PORTABLE

CONSOLE

RACK MOUNT

### NEW POSITIVE DRIVE

Two-speed hysteresis synchronous motor prevents timing errors, lost program time.

### N.A.B. 10<sup>1</sup>/<sub>2</sub>" REELS

Now get long playing time even on portable equipment. No overlap on rack mount.

### PT7's Greater Flexibility Means Greater Value

The PT7 Recorder Mechanism and Amplifiers incorporate Magnecord's exclusive Unit Construction. The same equipment can be used in console cabinet, rack mount, or for portable operation. New PT7-P amplifier features high-level mixing for 3 high impedance microphones.

#### Write For Detailed Information

Revolutionary new PT7 specifications have just been released. Write for your copy today.

**Magnecord, INC.**

360 N. MICHIGAN AVENUE • CHICAGO 1, ILLINOIS

### 3 HEADS

Separate heads for Erase, Record, and Playback now allow monitoring off the tape.

### PUSHBUTTON CONTROLS

Separate buttons for "Forward," "Rewind," and "Stop" can be operated by remote control.

World's Largest and Oldest Manufacturers of Professional Magnetic Recorders

# DOUGLAS AND MACADIE

## Automatic COIL WINDERS

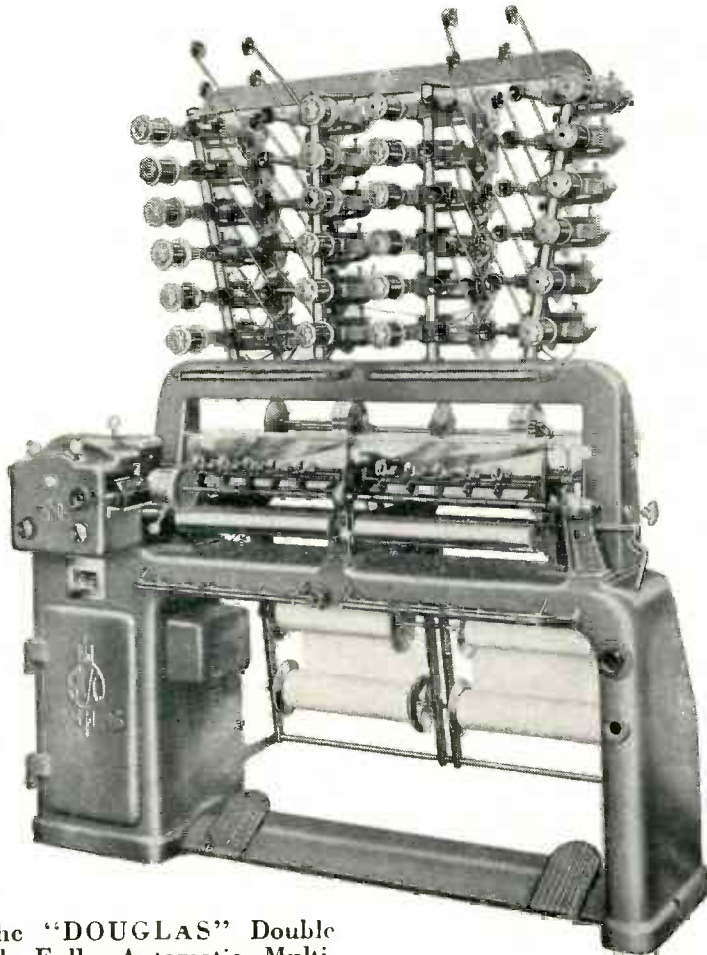

The "DOUGLAS" Double Bank Fully Automatic Multi-Winder is eminently suitable for the high-speed production of large quantities of coils with or without paper interleaving.

It will wind round, square or rectangular coils from 1-inch (25.4 mm.) to 5-inches (127 mm.) in length and up to 4-inches (102 mm.) diameter or diagonal. As many as 24 coils can be wound simultaneously (depending on the gauge of wire

being used), the total winding length of the machine being 30-inches (762 mm.).

Wires from 42 to 30 a.w.g. can be handled at variable head-stock speeds of between 600 and 2,000 r.p.m., the machine being fitted with a specially designed rapid-change gear box and a variable speed totally enclosed motor.

The machine, which incorporates the most up-to-date refinements is supplied complete with a special sliding seat which enables the operator to effect complete control without undue effort.



Our complete catalogue contains illustrations of numerous other Coil Winding and Taping Machines. A copy will be sent to interested executives on application.

**THE AUTOMATIC COIL WINDER & ELECTRICAL EQUIPMENT CO., LTD.**

Winder House • Douglas Street • London • S.W. 1 • England. Cables: "Autowinda, Sowest, London", Code: A.B.C. 5th

NEW PRODUCTS

(continued)

the new design of Powerstat types 116 and 216 variable transformers. Type 116 operates from a 115-volt, 50 or 60-cycle source to deliver 0 to 135-volt, 7.5-ampere output. Type 216 has an output of 0 to 270 volts, 3.0 amperes from 230 volts, 50 or 60 cycle, single phase. The new design makes the unit more rugged, protecting it against the abuses of constant use and rough shipping treatment.



### Vacuum Gage

HASTINGS INSTRUMENT CO., INC., Box 1275, Hampton, Va., has announced a vacuum gage for measurements in the 1 to 1,000-micron range. Embodying a noble-metal thermopile and a dependable bridge circuit, the gage consists of an accurate electrical indicator and a small rugged pickup which screws into a  $\frac{1}{8}$ -in. tapped hole in the vacuum system. The unit operates on 115 volts a-c and is adaptable to such processes as vacuum tube manufacture, vacuum distillation and vacuum dehydration.

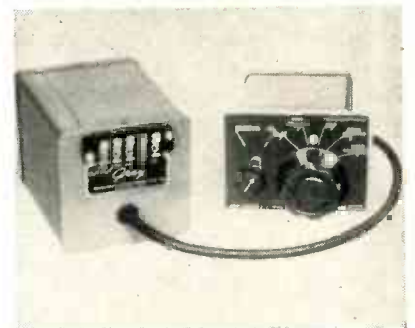

### Equalizer

GRAY RESEARCH AND DEVELOPMENT Co., INC., Hartford 1, Conn. Model 603 equalizer supplements the fea-



# Mr. Businessman!

## WHAT WILL THE 1950 CENSUS DO FOR YOUR BUSINESS?

### CONSUMER MARKET INFORMATION

The 1950 Census will provide a huge amount of information about the characteristics of the consumer market. It will tell you what kind of income groups live where . . . what they have and what they need in the way of commodities from automobiles to television sets down to plumbing fixtures. The Census is an accurate survey of economic conditions in your market area. It will not only tell you *where* your customers are, but *what they need that you have to sell them!*

It will show where improved transportation and shipping facilities are needed . . . better harbors and waterways . . . stepped-up Public Service.

That is why the 1950 United States Census is vital to your business!

### COOPERATION

You know that the Census-Taker is not just "counting heads." He's actually making a survey of existing conditions in industry, business, employment, housing, education. You know census information is as confidential as the vote you cast! Because you know all these things you'll cooperate with the Census-Taker in every way when he calls on you.

### WHAT ABOUT THE OTHER FELLOW?

But! What about the people who work for you? The man in the shop . . . your own secretary . . . the fellows in the shipping room. Do they know all this about the Census? Chances are some of them do, so the idea is to get the right information across to those who don't!

### WHAT'S THE BEST WAY?

If it's possible, call everyone together and talk about it . . . ask questions . . . exchange ideas. If your outfit is

too big for that, direct a Census information memorandum to all your employees. Post information on the bulletin boards. Run a Census story in the company house organ. Talk about it. *Every way you can . . . get the people who work for you to cooperate with the Census.*

### WHAT DOES THE 1950 CENSUS MEAN TO YOUR EMPLOYEES?

Better schools . . . school buses . . . school lunches. It means finer roads, bridges and highways . . . increased transportation facilities . . . improved safety regulations. It creates more efficient Public Service and furthers adequate distribution of utility services such as telephones, gas, water and electric power. It will help your community plan better parks, playgrounds, recreation areas and housing. It will mean higher living standards and accurate congressional representation. The Census is *everybody's voice in America's future!*

### YOU OWE IT TO YOURSELF . . .

Mister Businessman . . . to your business and your community! Put your efforts behind the 1950 United States Census for an even better country to live in . . . the *best* country to do business in!

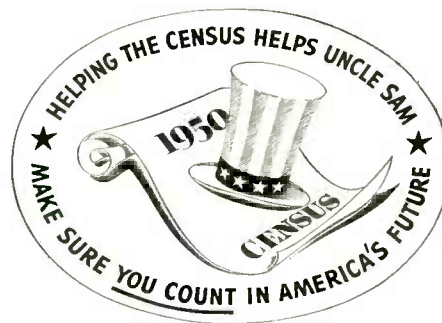

Published in the public interest by:

# McGRAW-HILL PUBLICATIONS



# ECONOMY ACCURACY STABILITY COMPACTNESS



## Have your Cake . . . and Eat it, too, with JELLIFF ALLOY 1000 RESISTANCE WIRE

The new high in Resistivity—100 ohms/cm—plus an impressive array of important electrical and physical characteristics, make our new ALLOY 1000 the most desirable material for windings in compact, precision resistors of all types. And the best thing about it is that you don't gain one characteristic at the cost of serious losses elsewhere. Write today for Bulletin 17, with the full story and technical data on JELLIFF ALLOY 1000 RESISTANCE WIRE



All you need . . .



for complete oscillographic recording

The S-8 Oscillograph, long the standard of oscillographic recording, has been improved to meet the expanding demands of modern research. The NEW Type S-8 Oscillograph has all the inherent capabilities you need to record rapidly changing phenomena such as vibration and dynamic strain.

### A few of the newest features are:

**QUICK-CHANGE TRANSMISSION**—16 record speeds over range of 120:1  
**FULL RESILIENT MOUNTING** makes possible use of super-sensitive galvanometers

**CHART TRAVEL INDICATOR** provides continuous indication of chart motion  
**NEW GALVANOMETER STAGE** takes all Hathaway galvanometers for recording milliamperes, microamperes, and watts.

**NEW RECORD-LENGTH CONTROL** and **NUMBERING SYSTEM** for long, trouble-free service

All the other valuable features characteristic of the S-8 are retained. Investigate the NEW Type S-8 and its 170 types of galvanometers.

Write for Bulletin 2B1 A-G

*Hathaway*  
INSTRUMENT COMPANY.  
1315 SO. CLARKSON STREET • DENVER 10, COLORADO

## IN PRECISION RESISTORS

## JOHNSON VARIABLE CONDENSERS

.. Always a Perfect Choice

Available in a wide range of types, in capacities and voltage ratings to meet every need. All incorporate latest design, finest materials and workmanship — your assurance of perfect satisfaction always. Here are just a few in the JOHNSON line.



### TYPE M MINIATURE

Tiniest, with dime sized plates, but proving ever so important for VHF applications such as TV, FM and others. Precision engineered and manufactured for exacting uses. Made in Single (180 degrees rotation) and Differential types up to 19.3 mmfd. maximum and Butterfly type up to 11 mmfd. maximum. Air gap .017", end plate 5/8" x 3/4".



### TYPE L

Newest development, employing metal to ceramic soldered joints — not a rivet or eyelet used. Utmost stability and strength, ideal for peak performance under severe conditions such as portable — mobile operation. 15 standard sizes with .030 plate spacing; single section up to 200 mmfd., Dual Section up to 100 mmfd., Differential up to 51 mmfd., and Butterfly up to 51 mmfd., .080 spacing also available. End plate only 1-3/8" square.

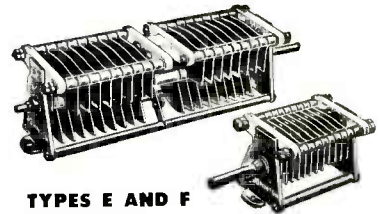

### TYPES E AND F

For medium and low power transmitters. Proved over many years use. Unusually compact. 45 standard sizes in air gaps of .045" (up to 500 mmfd. maximum capacity), .075" (up to 350 mmfd.), and .125" (up to 250 mmfd.). Single and Dual Section Types. Panel space "E" about 2-5/8" square, "F" about 2" square.

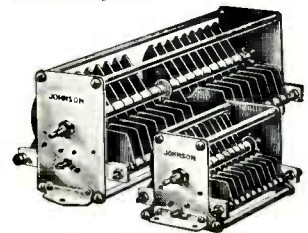

### TYPES C AND D

Rugged condensers with heavy, well rounded plates and exceptionally long steatite insulators for higher voltages. 52 standard sizes in air gaps of .080" (up to 500 mmfd.), .125" (up to 300 mmfd.), .175" (up to 500 mmfd.), .250" (up to 350 mmfd.), .350" (up to 250 mmfd.) and .500" (up to 100 mmfd.). Special spacings and capacities easily provided. Single and Dual Section types. Panel space, "C" about 5-1/2" square, "D" about 4-1/4" square.



Variable Condenser Catalog No. 701, free on request.

**E. F. JOHNSON COMPANY**  
WASECA, MINNESOTA



tures of model 602 by providing a greater range of response curves and additional compensation to accommodate pickups of different characteristics. The high-frequency characteristics obtainable comprise 5 steps, ranging from flat response to a heavy roll-off for worn records. A selection of 150 or 200-ohm output can be made by making appropriate connections to the terminal board.



### D-C Amplifier

C. G. S. LABORATORIES, INC., 36 Ludlow St., Stamford, Conn. The d-c amplifier illustrated has an output of 200  $\mu$ a or 3 volts across 15,000 ohms, for an input of 500  $\mu$ v; a multiplier switch extends this input to 5 mv, 50 mv, and 500 mv. Input impedance is one megohm. Noise generated in its air-coupled chopper is equivalent to 2 to 3- $\mu$ v input signal. Use of an electronic ripple filter and paper capacitors assures satisfactory operation over an ambient temperature range from -55 C to +85 C.



### Vibrator Inverter

CORNELL-DUBILIER ELECTRIC CORP., South Plainfield, N. J. The Power-con line of d-c to a-c inverters is

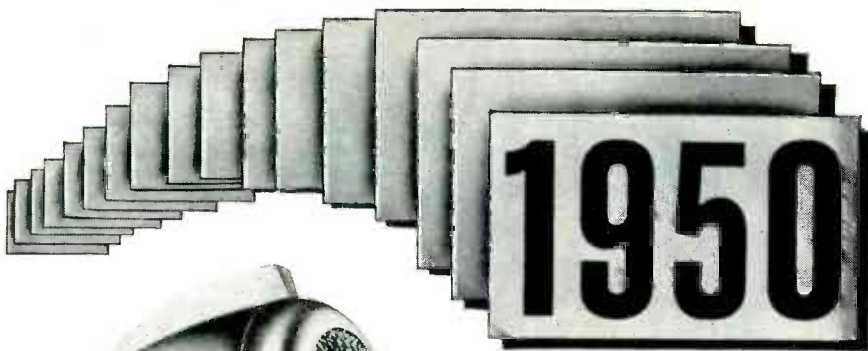

*A Sound Performer*  
**YEAR AFTER YEAR**

### THE TURNER MODEL 22

● Twelve years have rolled by since the Turner Model 22 was introduced. A "best seller" from the start, its popularity must be deserved.

Write for Complete Microphone Literature

Welcome to  
509A  
Our headquarters  
at the Stevens  
during the  
Parts Show  
MAY 22-25

### THE TURNER COMPANY

905 17th Street N. E. • Cedar Rapids, Iowa

IN CANADA:

Canadian Marconi Co., Montreal, P. Q., and Branches

EXPORT:

Ad. Auriema, Inc., 89 Broad Street, New York 4, N. Y.

*Microphones* **BY TURNER**



Crystals licensed under patents of the Brush Development Company

*Now Terminals Can Be  
**ATTACHED & SOLDERED**  
in ONE Automatic Operation!*

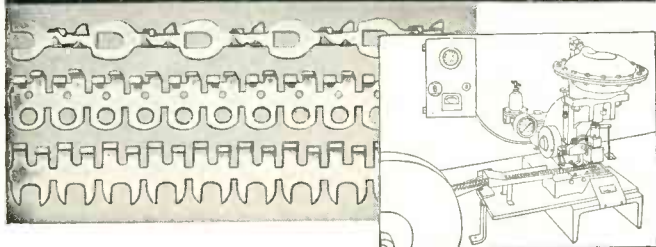

**New Terminal Attaching Machine**

attaches and solders various sizes and types of pre-soldered tandem terminals (supplied on reels) at rates up to 1200 per hour. Machine cuts off, clinches and solders terminals in one instantaneous operation. Eliminates handling of loose terminals, solder and flux to increase production and lower costs on long runs. Standard types available. Strong, perfectly soldered joints are assured, as absolute control of heat is maintained. Send for detailed information, enclose sample of wire and terminal now used. Address Dept. E.

*For ordinary runs in moderate quantity we continue to produce.*

**SEPARATE TERMINALS for ELECTRIC WIRES**

We also make **SMALL METAL STAMPINGS**, exact to Customer's Prints. Modern Plant, Equipment and Methods. Precision Work. Moderate Die Charges. Prompt, Dependable Service.

**PATTON-MacGUYER COMPANY**  
17 Virginia Avenue, Providence, R.I.

**SYNTHESIS**  
IS A HIGH CLASS WORD  
FOR DESIGNING  
SERVO MECHANISMS



**... SERVOSCOPE IS A HIGH CLASS INSTRUMENT FOR SERVO SYNTHESIS!**



**WRITE FOR INFORMATION**

- MEASURES** amplitude & phase vs. frequency
- CARRIERS** accepted, 50 to 800 cps
- MODULATES** chosen carrier, 0.1 to 20 cps
- ANALYZES** D.C. or A.C. automatic controls
- SUB-AUDIO** sine generator, 0.1 to 20 cps
- SQUARE WAVE** generator, 0.1 to 20 cps
- PHASE READING** to 1° accuracy, 2 methods
- LINEAR SWEEP** for external use, 0.1 to 20 cps

**SERVO CORP. OF AMERICA**  
**NEW HYDE PARK, N. Y.**

New Books in the  
**NATIONAL NUCLEAR ENERGY SERIES**

**The Characteristics of Electrical Discharges in Magnetic Fields**

1. This volume collects the results of studies carried out in the California Radiation Laboratory on the characteristics of electrical discharges in magnetic fields. Primary emphasis is placed on the case of electrical discharges in the vapors of uranium compounds. By A. Guthrie and R. Wakerling, Univ. of Cal. \$3.50.

**Vacuum Equipment and Techniques**

2. A compilation of observations made in the course of developing high vacuum equipment for use in electromagnetic separation plants. Noteworthy is the book's discussion of the use of the vacuum analyzer and helium leak detector. By A. Guthrie and R. Wakerling, Univ. of Cal. \$2.50.

Two distinguished books in the  
**RADIATION LABORATORY SERIES**

**Threshold Signals**

3. Provides an analysis, both theoretical and experimental, of the factors which affect the perception of desired signals in the presence of various kinds of interference, principally inherent receiver noise. In addition to signals which consist of trains of pulses, a treatment is given of pulse trains which are amplitude modulated in some desired way. By J. Lawson, Gen. Elect. Research Lab., and G. Uhlenbeck, Univ. of Mich. \$5.00.

**Vacuum Tube Amplifiers**

4. Brings you modern research findings on the principles, constructional techniques and special problems of vacuum tube amplifiers. The amplifiers discussed are designed to have extreme values in one of several of the pertinent characteristics: bandwidth — sensitivity — linearity — constancy of gain over long periods of time, etc. By G. E. Valley, Jr., M.I.T., and H. Wallman, M.I.T. \$10.00.

**10 DAYS' FREE EXAMINATION**

McGraw-Hill Book Co., Inc., 330 W. 42 St., NYC 18  
Send me book(s) corresponding to numbers enclosed below for 10 days examination on approval. In 10 days I will remit for these books, plus few cents for delivery, or return book(s) postpaid. (We pay for delivery if you remit with this coupon; same return privilege.)

1                      2                      3                      4

Name.....

Address.....

City..... Zone..... State.....

Company.....

Position..... L-4-50

This offer applies to U. S. only



generally used to create 110-v, 60-cycle a-c from battery or other d-c sources. All for use with radio or tv equipment are filtered for clear reception and are capable of starting under full load without the necessity of starting the converter first and then applying the load. Information on various models is available.

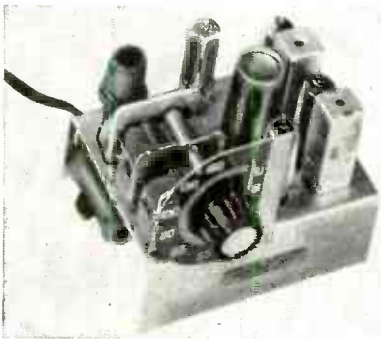

**Superhet Tuner**

APPROVED ELECTRONIC INSTRUMENT CORP., 142 Liberty St., New York 6, N. Y. Model A-600 broadcast superhet tuner is completely filtered and hum free. It is designed for use in public address systems, portable amplifiers, record players, wire and tape recorders and motion picture sound projectors. Output is adjustable in 3 steps of 10 v, 5 v and 1 v. The unit has a self-contained 115-volt a-c/d-c power supply.

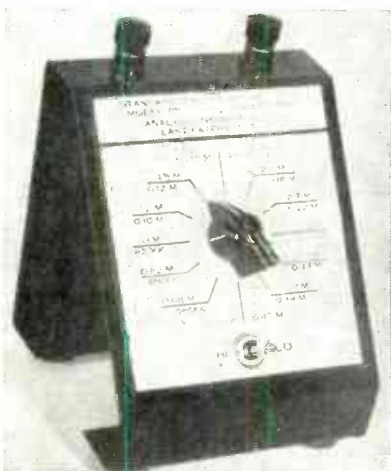

**Resistance Box**

ANALYSIS INSTRUMENT Co., P.O. Box 231, East Paterson, N. J., is now offering a resistor decade for



**here's your  
one-stop source  
for fastening service**

1849

1950

*Slotted or Phillips head machine screws, wood screws, stove bolts, tapping screws, special headed products; nuts, rivets, chaplets, wire forms, screw machine products . . . in steel, stainless steel, copper, brass, bronze, everdur, nickel, nickel silver, monel, aluminum . . .*



**THE BLAKE & JOHNSON COMPANY, WATERTVILLE 48, CONN.**

Please send me your new catalog containing full data on the complete line of Blake & Johnson fastenings.

Name .....

Title .....

Company .....

Address .....

E-4

a **+** value for industry  
Development and Production of

# SPECIAL PURPOSE VACUUM TUBES BY ECLIPSE-PIONEER

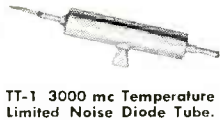

TT-1 3000 mc Temperature Limited Noise Diode Tube.



Y-Type Position Convectron—Vertical Sensing Tube.



Chronotron Thermal Time Delay Tube.

We're not in the standard vacuum tube business. But we are definitely in the business of developing and manufacturing special purpose vacuum tubes — tubes that are not generally available. During the past three years, for example, our facilities have produced, such devices as the Chronotron thermal time delay tube, the Convectron\* vertical sensing tube, the TT-1 3000 mc temperature limited noise diode tube, counter tubes, glass enclosed spark gaps, and phono pickup tubes. Quantities of all these are now serving many phases of industry in a wide variety of applications. We invite your use of our facilities to develop and produce your requirements of special purpose vacuum tubes. Your inquiries concerning the scope of our facilities or details of any of our tubes will be given immediate attention.

\*REG. U.S. PAT. OFF.

Eclipse-Pioneer Division of  
TETERBORO, NEW JERSEY



Export Sales—Bendix International Division, 72 Fifth Avenue, New York 11, N. Y.

When the situation  
calls for **BETTER**  
**COILS.....**



## PRECISION PAPER TUBES

Provide the **BASE!**

Precision Paper Tubes assure better coils by providing a superior coil base of finest dielectric Fish Paper, Cellulose Acetate, or combination, that improves insulation, has lower moisture absorption. Spirally-wound and heat-treated for greatest strength, they're lighter; afford greater heat dissipation.

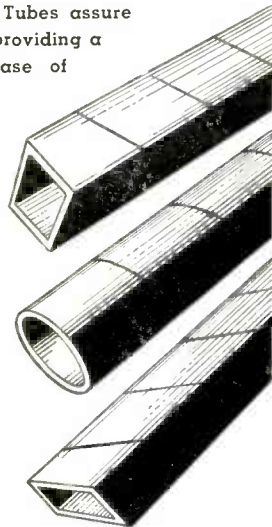

Whether your coils be round, oval, square, rectangular or other shape—regardless of their length, ID or OD—we can supply a Precision Coil Form made exactly to your specifications. Write or wire today for new Mandrel List of over 1,000 sizes. Ask about new Precision Di-Formed Paper Tubes that allow making more compact coils at no extra cost.

**PRECISION PAPER TUBE CO.**

Also makers of Precision Coil Bobbins

2041 W. Charleston St., Plant #2, 79 Chapel St.,  
Chicago 47, Ill. Hartford, Conn.

—more compact, higher accuracy!

TYPES WL  $\frac{5}{8}$  and WLA  $\frac{5}{8}$



**1/2 WATT  
INDUCTIVE**  
MAX. RES.: .01 to 7,500 ohm (331 Alloy)  
.01 to 4,000 ohm (Nichrome)  
.01 to 1,250 ohm (Manganin)  
BODY SIZE:  $\frac{5}{8}$ " lg. by  $\frac{3}{16}$ " diam.  
TOLERANCE: STANDARD 1%

TYPES WL and WLA



**1 WATT  
INDUCTIVE**  
MAX. RES.: .01 to 15,000 ohm (331 Alloy)  
.01 to 8,000 ohm (Nichrome)  
.01 to 2,500 ohm (Manganin)  
BODY SIZE: 1" lg. by  $\frac{3}{16}$ " diam.  
TOLERANCE: STANDARD 1%

Can be supplied non-inductive with one-half indicated maximum resistance.

### Economical in Cost

IN-RES-CO WL series resistors were designed to meet increasing demands for a compact resistor of high accuracy priced for general use. They meet the most critical requirements—close tolerance, ability to withstand overload, long life. Write today for catalog describing the full line of quality IN-RES-CO resistors.

**IN-RES-CO**  
APPLICATION-DESIGNED  
**RESISTORS**



**INSTRUMENT RESISTORS CO., 1056 COMMERCE AVE., UNION, N. J.**



electronic production and laboratory use. Model 101 contains all RMA 10-percent resistance values from 47,000 ohms to 2.7 megohms, ½-watt dissipation and 10-percent accuracy; model 102, values from 680 ohms to 39,000 ohms. These decades make it possible to place RMA resistor values in a circuit without drawing a number from stock for trial. It also eliminates the potentiometer-ohmmeter method of first approximation of circuit values.



**Miniature Receiving Tube**

GENERAL ELECTRIC Co., Syracuse, N. Y. Type 6CB6 miniature receiving tube can be used as a wideband amplifier in the i-f or r-f stages of television and f-m receivers. This sharp-cutoff pentode has a trans-conductance of 6,200 micromhos and a plate current of 9.5 ma under typical operating conditions. The suppressor and cathode of the tube are brought out on separate base pins to allow greater flexibility in design.

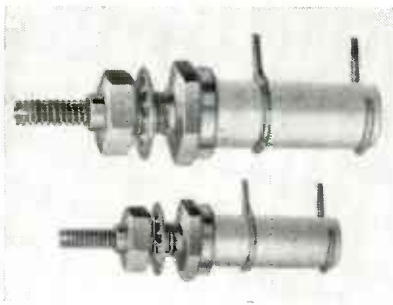

**Ceramic Coil Forms**

CAMBRIDGE THERMIONIC CORP., 437 Concord Ave., Cambridge 38, Mass.,



**A WIDE RANGE portable TV scope**

- ✓ Response Flat to 5 Mc.
- ✓ Triggered Time Base
- ✓ Built-in 2-microsec. Delay Line
- ✓ Intensifying and Blanking Amplifier

• Truly a laboratory instrument, the WO-79B 3-inch oscilloscope is outstanding for a wide range of research and industrial applications. It is particularly useful for the observation and measurement of phenomena such as TV synchronizing and deflecting voltages, ignition waveforms, pulses, and radar signals. The WO-79B will accurately display 1-microsecond pulses and other waveforms which have extremely steep leading edges, such as are encountered in photo-flash devices and electro-mechanical relays.

The WO-79B features a triggered saw-tooth sweep with a delay network, two-to-one trace expansion, vertical amplifier flat from 10 cycles to 5 Mc, calibrating meter for voltage measurements, high voltage for photography of transients, wide-range centering controls, and re-

tractable light shield. It is shipped complete with compensated attenuating cable, and with a direct probe cable.

Ask your local RCA Test Equipment Distributor for further details, or write RCA, Commercial Engineering, Section D42Y, Harrison, N. J.

SPECIFICATIONS	
Frequency Range	Vert. Amplifier... ±20%, 10 cycles to 5 Mc/sec
	Horiz. Amplifier... ±10%, 10 cycles to 500kc/sec
Deflection Factor (for 1100 volts at second anode)	Vert. Amplifier... 10.18 RMS volt/inch
	Vert. Amplifier... 10.5 peak-to-peak volt/inch
Sweep Frequency Range	... 20 cycles to 250 kc/sec
Triggered-sweep Repetition Rate	... up to 50 kc/sec
Blanking	... Return trace blanked on triggered deflection
Power Supply	... 105/125 volts, 50/60 cycles
Power Consumption	... 200 watts
Dimensions	... 14½" high, 8¼" wide, 15¼" deep
Weight	... 42 lbs.
	*For Sine Waves

Available from your RCA Test Equipment Distributor



**RADIO CORPORATION of AMERICA**  
TEST EQUIPMENT

HARRISON, N. J.

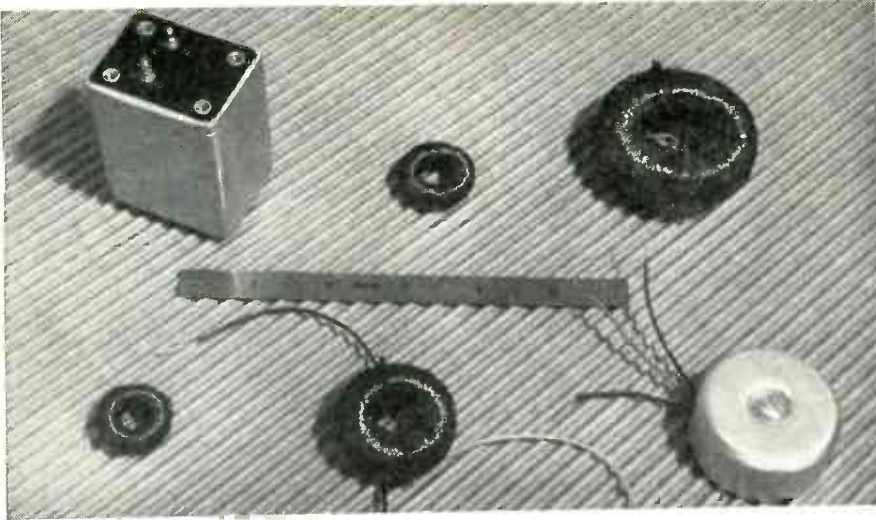

## TOROIDS—*for Performance*

Close tolerance toroidal coils wound on  $\frac{3}{4}$  inch diameter, or larger, cores. Inductance tolerances can be maintained to 0.1%. Available with balanced windings, taps and close-coupled secondaries.

Where a wide frequency range of operation is required, coils with extremely low distributed capacity are available.

*Lenkurt knows how*

**LENKURT ELECTRIC CO.**  
SAN CARLOS • CALIFORNIA

*Lenkurt*

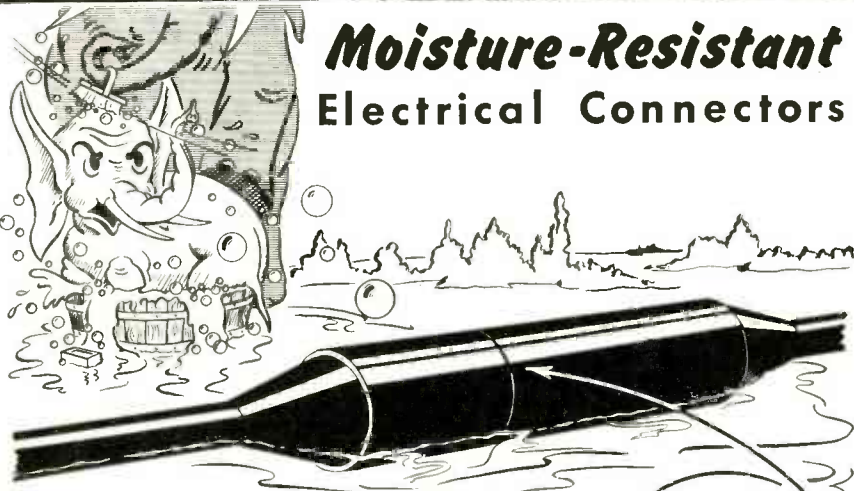

## Moisture-Resistant Electrical Connectors

No question about it . . . JOY plugs and sockets are today's outstanding electrical connector value! Molded as one-piece Neoprene units and factory vulcanized to cords, they won't crack or shatter under hard blows—are surprisingly immune to climatic changes—and are trim, safe and easy to handle. Whenever advantageous, JOY Connectors are equipped with the famous MINES "Water-Sealing" face. Cut-away illustration in circle shows how close fitting segments on mating Male and Female plugs positively "Seal-out" dirt and moisture by enclosing contacts in a resilient rubber housing. Ask for a complete description on this and other advantages that only JOY Connectors provide.

A wide variety of sizes, shapes and pin combinations are available to meet the portable power requirements of TV, FM, AM or PA Circuits. Illustrations show JOY'S No. 2C156M Portable Male Plug and No. 2C156F Portable Female.

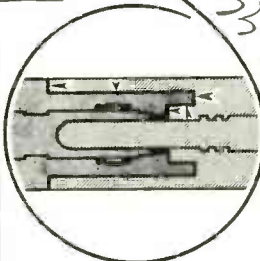

MALE & FEMALE PLUG ENGAGED  
Note 5-way WATER-SEAL (arrows)

ME-150.3

MINES EQUIPMENT — MINES — Division

**JOY MANUFACTURING COMPANY**

HENRY W. OLIVER BLDG., PITTSBURGH 22, PENNA.

# COSSOR *for* QUALITY

## TWIN-BEAM OSCILLOSCOPES



MODEL 1035 Provides **FAST SWEEPS**, from 150 Millisee. to 5 Microsec., and **Video Frequency Amplifiers**, Stepped -VE Feedback Type, with Gain of 3 at 7 Mc. Bandwidth to Gain of 3000 at 80 Kc. Bandwidth,  $\pm 1.5$  DB. **PLUS** Triggered Sweeps, Suppressed Flyback,  $\pm$  VE Sync.

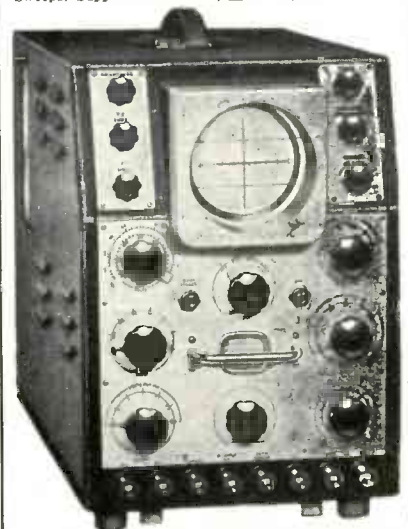

MODEL 1049 Provides **SLOW SWEEPS** from 1.5 Sec. to 50 Microsec., and **D.C. Amplifiers** Completely Stabilized Throughout. Response 0-100 Kc.  $\pm 1.5$  DB. Gain 900, **PLUS** Beam Blanking Circuits, Triggered Sweeps,  $\pm$  VE Sync.

**PLUS**

Unique **TWIN BEAM** Flat Face CRT in **BOTH** Instruments Providing Instant Directly Calibrated Measurement for Accurate Voltage, Time and Phase Comparisons.

WRITE TODAY FOR LITERATURE  
AND DEMONSTRATION

**COSSOR (CANADA) LIMITED**  
WINDSOR ST., HALIFAX, N.S.

**BEAM INSTRUMENT CORP.**  
Room 208, 55 W. 42nd St., New York 18



recently announced two new ceramic coil forms. Coded LS-5 and LS-6, they are made of silicone impregnated ceramic (grade L-5, JAN-I-10) for high resistance to moisture and fungi. The LS-5 is  $1\frac{1}{8}$  in. high and  $\frac{3}{8}$  in. in diameter; LS-6 is  $\frac{1}{2}$  in. high and  $\frac{1}{8}$  in. in diameter. Ring terminals are adjustable. Both sizes are provided with a spring lock for the slug, and both are available with high, medium or low-frequency slugs.

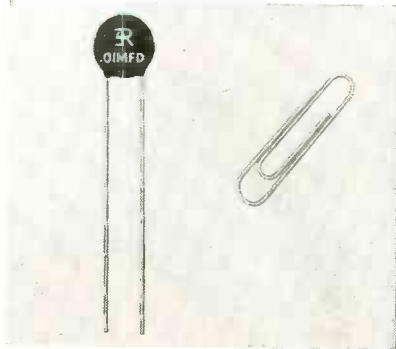

### Midget Capacitor

ERIE RESISTOR CORP., Erie, Pa., is now manufacturing a 0.01- $\mu$ f disc Ceramicon capacitor which is  $19/32$  in. in diameter. Voltage rating is 400 volts d-c, which is based on a life test of 800 volts d-c at 85 C for 1,000 hours. Power factor is 2.5 percent maximum at 1 kc at not more than 5 volts rms. Insulation resistance is 7,500 megohms minimum.



### Precision Switch

W. L. MAXSON CORP., UNIMAX SWITCH DIVISION, 460 W. 34th St., New York 1, N. Y. Type SXX snap-acting precision switch is rated at 15 amperes, 250 volts a-c; 20 amperes, 125 volts a-c;  $\frac{1}{2}$  h-p

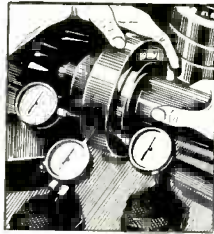

### with BALL BEARINGS

— the small extra first cost of test samples pays off in assurance of efficiency and durability of the finished mechanism.

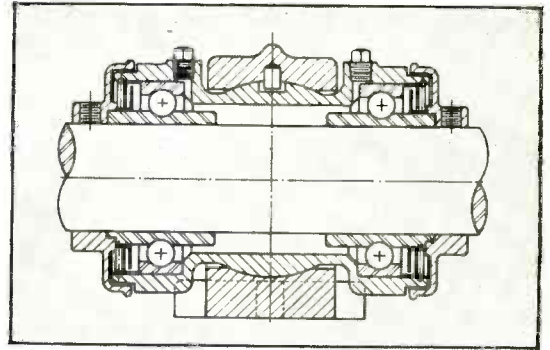

### with TRACING CLOTH . . .

The small extra first cost of Arkwright Tracing Cloth, over that of tracing paper, repays many times over in the efficiency and durability of valuable drawings.

Through continued research and development plus skilled manufacturing processes, Arkwright Tracing Cloths meet every requirement of exacting draftsmanship. You'll find no pinholes, stains or other imperfections to detract from drawing quality — nor smudging or feathering after repeated erasures. Most of all, you'll have highly transparent, long lasting usefulness that perishable tracing paper can never match.

For every drawing worth keeping for future use — specify permanent Arkwright Tracing Cloth. Send now for generous working samples. Sold by leading drawing material dealers everywhere. Arkwright Finishing Company, Providence, R. I.

#### The Big Six Reasons Why Arkwright Tracing Cloths Excel

1. Erasures re-ink without feathering.
2. Prints are always sharp and clean.
3. Tracings never discolor or go brittle.
4. No surface oils, soaps or waxes to dry out.
5. No pinholes or thick threads.
6. Mechanical processing creates permanent transparency.



**ARKWRIGHT**  
**TRACING CLOTHS**  
 AMERICA'S STANDARD FOR OVER 25 YEARS

# IMPROVED ULTRA-SENSITIVE DC AMPLIFIER



1. This new and improved DC amplifier of the General Motors breaker type offers many advantages in the measurement of DC and low frequency AC voltages in the micro-volt and fractional microvolt regions. It is useful for the amplification of low level thermocouple voltages, infra red detectors, photovoltaic cells and the like. It can be used to replace suspension galvanometer systems.
2. This new amplifier (Model 10) features very high immunity to the effects of AC pickup in the input circuit. The discrimination ratio against 60 cycle pickup is over 1000. It has an improved life breaker. Convenient and accurate coarse and fine gain controls, zero position controls and calibration signals are provided.
3. This instrument has a zero stability of better than .005 microvolts per day after warm up. The noise level approaches the limit imposed by the Johnson noise of the external circuit. This amplifier is available for operation with input circuits from 0 to 1 megohms. The DC output of the amplifier is sufficient to operate standard recorders, milliammeters and DC relays. For 110 volts, 60 cycle operation.

Price \$580.00

For complete information, write

## LISTON-FOLB

Division of Atlas Coil Winders, Inc.

DEPT. M  
STAMFORD

P.O. BOX 1334  
CONNECTICUT



# NATIONAL

- Proven
- Dependable
- Quality



## RECEIVING TYPE CONDENSERS

National's famous receiving-type condensers are available with either straight-line wave-length plate shape or straight-line capacity plate shape. Special features can be supplied in quantity, such as serrated rotor plates, staked rotor and stator plates, shaft extensions for ganging and special capacities as high as 335 mmf. for single-section and 100 mmf. per section for dual condensers. Commercial inquiries invited.

# EISLER Television Tube MACHINERY

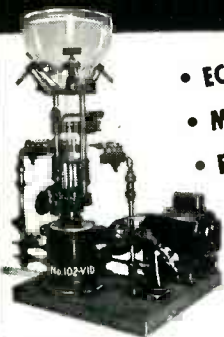

No. 102-VID



No. 57-VID

- ECONOMICAL
- MODERN DESIGN
- PRODUCTION ENHANCING

EISLER'S Electronic Equipment is especially Designed and Built to your exact requirements.

From 5" to huge 24" Television Tube

EISLER specializes in GLASS WORKING MACHINERY for the manufacture of: Cathode Ray; Radio Tubes (Standard, Miniature, Sub Miniature); Fluorescent Lamps; Glass Ampoules; Vials; Incandescent Lamps.

- Consultation without any obligation on your part is cordially invited.

## EISLER ENGINEERING CO., INC.

751 SOUTH 13th ST. • NEWARK 3, NEW JERSEY

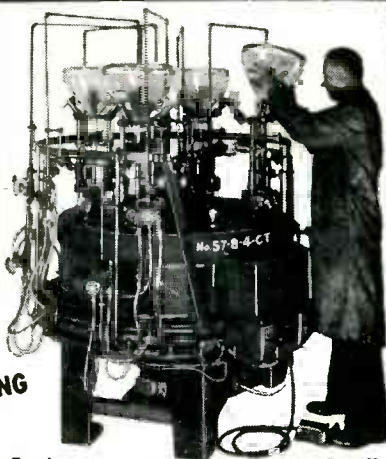

No. 57-8-4-CT



RESISTANCE  
WELDERS

1/4 to 300 KVA



EISLER TRANSFORMERS  
STANDARD • SPECIAL  
Air, Oil or Water  
Cooled

Sizes From 1/4 to 500 KVA





125, 250 and 460 volts a-c. Force and movement specifications are as follows: operating force—9 to 13 oz; release force—4 oz minimum; movement differential—0.005 in. maximum; pretravel—0.025 in. maximum; overtravel—0.005 in. minimum.

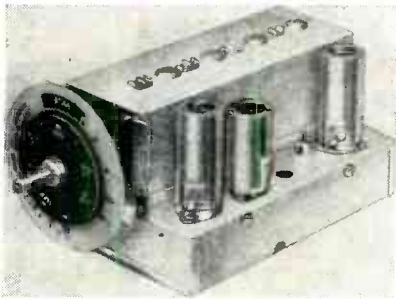

### Inputuner

ALLEN B. DU MONT LABORATORIES, INC., 35 Market St., East Paterson, N. J., has introduced the four-section Inputuner, incorporating the latest spiral-type Inductuner. Tuning range is continuous from 54 to 216 mc, inclusive, covering the tv channels 2 to 13 as well as the f-m band. It requires only 5.9 turns of tuning motion as against 10 turns for previous models. It operates efficiently on either 300 or 72-ohm antenna systems by means of an input transformer.



### Nylon Lacing Cord

HEMINWAY & BARLETT MFG. CO., Watertown, Conn., has developed a new Nylon lacing cord for winding around the leads and wires of electronic equipment to bind them firmly together and prevent their fouling with working parts. Its coating resists mold and micro-organisms and, at the same time, retains malleability. Tensile

## WEBSTER ELECTRIC Quality Cartridge MODEL A

- No Installation Problem
- No Servicing Problem
- Positive Tracking at all Speeds



Furnished with complete twist mechanism for mounting in tone arms.

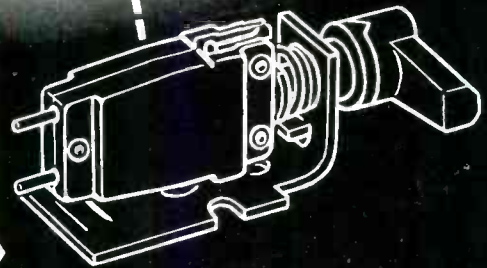

### Fits All Standard Tone Arms

Plays 33 $\frac{1}{3}$  and 45 RPM or 78 RPM Records

Webster Electric Cartridge Model A is a versatile, miniature-size cartridge which is furnished complete with brackets permitting its use in nearly every record changer tone arm on the market today. Designed to play 33 $\frac{1}{3}$  and 45 RPM or 78 RPM records, it tracks at only 7 grams. Its extremely light weight simplifies counter-balancing problems. Its small size and simplified, foolproof mechanism make it the ideal cartridge for three-speed record changers.

Write us for complete information, prices or samples for tests.

**WEBSTER**  **ELECTRIC**

Webster Electric Company, Racine, Wisconsin • Established 1909

"Where Quality Is a Responsibility and Fair Dealing an Obligation"

# POLARAD LABORATORY Equipment

for studio • laboratory • manufacturer

## 20 MC VIDEO AMPLIFIER Model V

- Flat frequency response from 100 cps to 20 mc  $\pm$  1.5 db.
- Uniform time delay of .02 micro-seconds.
- Gain of 50 db.
- Frequency compensated high impedance attenuator calibrated in 10 db steps from 0-50.
- Fine attenuator covers a 10 db range.
- Phase Linear with frequency over entire band.

This unit is designed for use as an oscilloscope deflection amplifier for the measurement and viewing of pulses of extremely short duration and rise time, and contains the Video Amplifier Unit, Power Unit and a low Capacity Probe.

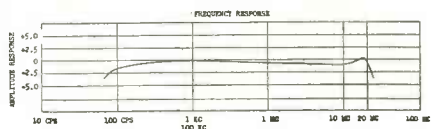

### Specifications

Input Impedance: Probe—12 mmf + 470,000 ohms; Jack—30mmf + 470,000 ohms; Output Impedance 18mmf + 470,000 ohms each side push pull; Max. Input Volts 500 peak to peak with probe; Max. Output Volts 120 volts peak to peak (push pull); Power: 115 volts 50/60 cps AC Line; Size 19 1/4" x 22" x 14 3/4".

# Polarad

Electronics Corporation

100 Metropolitan Ave. Brooklyn 11, N. Y.

TELEVISION ENGINEERS and CONSULTANTS to the Nation's Leading Television Stations

## CUT COSTS

### IN FREQUENCY CONTROL DESIGN . . . with STANDARD Type 20

$\pm$ .002 %  
-55°C to +90°C

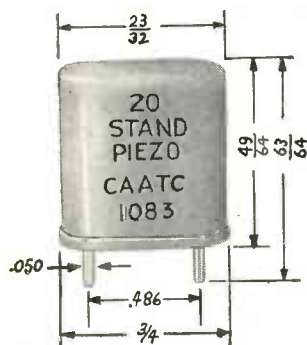

Improved processing of our hermetically sealed TYPE 20 Unit has made it possible to eliminate the cost of temperature control.

Type 20 meets all government specifications.

Lower power requirements, reduced weight, compactness, aging, ruggedness, and dependability in our improved TYPE 20 is your answer for reducing costs and increasing sales.

For complete details, write for Engineering Data.

# Standard Piezo Company

CARLISLE, PA.



**B**UILDERS OF COMMUNICATIONS EQUIPMENT, MEASURING INSTRUMENTS FOR COMMERCIAL AND INDUSTRIAL USE, AND OTHER ELECTRONIC DEVICES — PRODUCTS WHERE PRECISION PERFORMANCE LARGELY DEPENDS UPON TIME AS A FACTOR OF CONTROL — KNOW THEY

can rely on

# Cramer

DESIGN  
QUALITY  
ACCURACY



### RUNNING TIME METERS

Synchronous motor driven. Register automatically and cumulatively total operating or idle time on circuits, machines, systems.



### TIME DELAY RELAYS

Provide adjustable or fixed time delay between operation of a control circuit and subsequent opening or closing of a load circuit.



### SYNCHRONOUS MOTORS

Permanent magnet type for applications requiring a constant speed at a given frequency. Small size. 30" ounce torque. Twenty-eight speeds from 60 rpm to 1/24 rph.

For a wide range of standard timers and controls . . . or special adaptations for specific applications . . . consult R. W. CRAMER CO., Box No. 3, Centerbrook, Conn.

# Cramer

SPECIALISTS IN TIME  
AS A FACTOR OF  
CONTROL

INTERVAL • DELAY • CYCLE • IMPULSE • PERCENTAGE



strength is 52 lb. The synthetic resin finish has a melting point over 190 F.

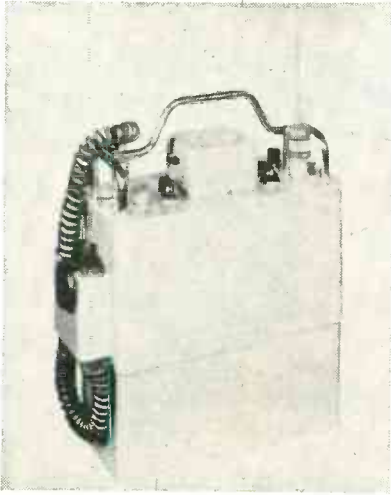

### Pack Set

MOTOROLA INC., 4545 Augusta Blvd., Chicago 51, Ill., has designed a new f-m 2-way pack radio for law enforcement agencies, fire departments, construction outfits, forestry services and similar organizations. The unit uses a 16-tube receiver and an 8-tube transmitter. Power output is 500 mw in the 25 to 50-mc band; and 250 mw in the 152 to 174-mc band. It is designed for operation from pack set to pack set, with a nominal range of 2 to 5 mi; from pack set to mobile unit, with a range of 7 to 10 mi. Subminiature tubes and cellular construction with individual plug-in stages are used.



### Frequency-Deviation Monitor

MOTOROLA INC., 4545 Augusta Blvd., Chicago 51, Ill., has announced for operators of two-way f-m radio systems a unit which measures: (1) the relative strength

# always ahead WITH THE NEWEST AND THE BEST IN PLUGS



### RADIO TERMINAL SERIES (left)

for radio chassis installations where low separation force is required. Leaf type contacts, with eyelet on terminal of plug side; crimp or solder holes on receptacles. Available in more than 5 sizes, for 18 or 20 wire; 5-amps; 2500 volts min. flashover.

### HERMETICALLY SEALED SERIES (right)

The "GS" or glass-sealed types are built for special equipment requiring a hermetic seal. AN-type layouts in limited selection for No. 12 wire or smaller; steel shell and contacts. Available with coupling nut (GS06 types) as well as GS02.

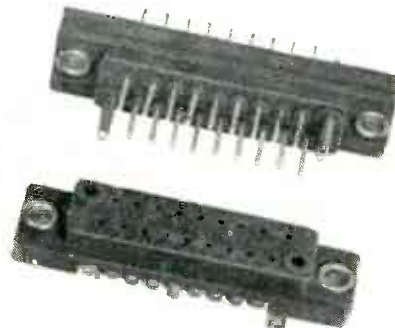

### RUBBER SEALED TYPES FOR RELAYS (right)

The "RS" types are rated as AN-"D" seal, which allows a minimal leakage. Used with relays, and carries standard AN inserts and coupling nuts.

Write to Cannon Electric Development Co., Division of Cannon Manufacturing Corp., 3209 Humboldt St., Los Angeles 31, Calif. Canadian offices and plant: Toronto, Ontario. World Export: Frazar & Hansen, San Francisco.

### DPM RACK AND PANEL TYPES (left)

Smaller than standard "DP" types with similar contact arrangement for mounting where dimensions must be kept at a minimum. Phenolic insulators; 120 volt, 10 and 5-amp. contacts. Fourteen and twenty contact arrangements available.



SINCE 1915

CANNON



ELECTRIC

REG. U.S. PAT. OFF.



# Flexible-Shaft Couplings

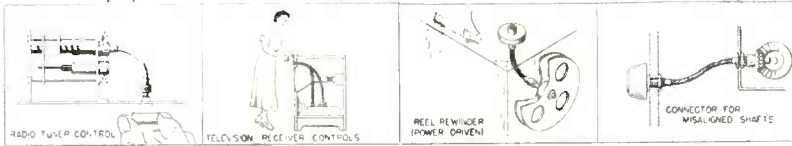
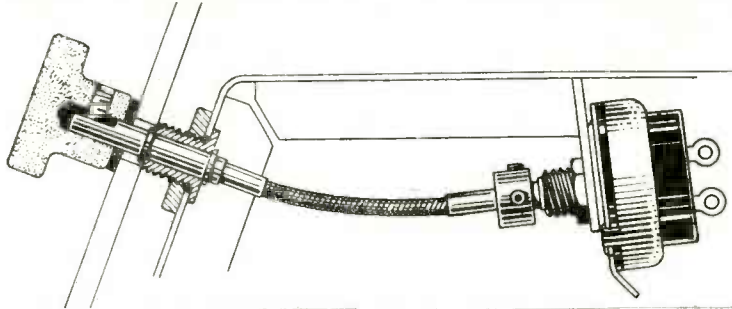

- MORE LIBERAL MANUFACTURING TOLERANCES
  - CUSTOM BUILT FROM STANDARD COMPONENTS
  - SHAFTING AVAILABLE IN DIFFERENT SIZES
  - ECONOMICAL TO USE
  - GREATER FREEDOM OF DESIGN
  - STANDARD END FITTINGS
- Write for bulletin showing
- DESIGN DATA
  - STANDARD END FITTINGS
  - TYPICAL FLEXIBLE SHAFT PROPERTIES

## WIRE SHIELDING & PUSH-PULL CONTROLS



### KUPFRIAN MANUFACTURING CO.

218 PROSPECT AVE. BINGHAMTON, N. Y.  
FORMERLY A DIVISION OF ELLIOTT MANUFACTURING COMPANY



**"PEL-X is  
BEST by TEST!"**

"Recently, one of our customers sent us, *unsolicited*, the findings on a test he conducted. In this experiment, PEL-X was tested along with seven similar tracing cloths and when the results were in, PEL-X topped the list on every count including evenness of pencil lines and workability — and by a substantial margin, too!"

This is proof that PEL-X can do everything as well as any other tracing cloth and some things better.

Find out for yourself just how good PEL-X really is by trying it on your drawing board. Put it to any test against any competitive tracing cloth and compare the results. We're sure you'll want to switch to PEL-X. Write for generous sample. \*Name on request.



## THE HOLLISTON MILLS, INC.

NORWOOD, MASS.

NEW YORK PHILADELPHIA CHICAGO

★ PEL-X is backed by Holliston's 50 years of leadership and experience in developing special purpose cloths for industry.

# NEW-

## THE HI-GAIN Industrial POCKETSCOPE

BY WATERMAN

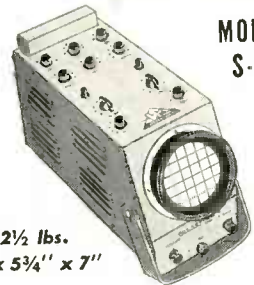

MODEL  
S-14-A

Wt. 12½ lbs.  
12" x 5¼" x 7"

A portable oscilloscope engineered to the exacting requirements of the electronic designer . . . a precision instrument that sacrifices nothing in performance characteristics or dependability because of its portable size or budget price . . . A giant in performance, a midget in size, the S-14-A POCKETSCOPE invites critical comparisons!

Identical Vertical and Horizontal channels with 10 mv/in sensitivity, response from 0 to 200KC within -2DB . . . Non frequency discriminating attenuators and gain controls . . . Internal calibration of trace amplitude . . . Linear time base oscillators with ± sync for either repetitive or trigger sweeps, from ½ cycle to 50KC . . . Trace expansion . . . Filter screen . . . Mu metal shield . . . and a host of other features.



WATERMAN PRODUCTS CO., INC.  
PHILADELPHIA 25, PA.

Waterman products include . . .

- |        |            |                    |
|--------|------------|--------------------|
| S-10-B | GENERAL    | <u>POCKETSCOPE</u> |
| S-11-A | INDUSTRIAL | <u>POCKETSCOPE</u> |
| S-14-B | WIDE BAND  | <u>POCKETSCOPE</u> |
| S-15-A | TWIN-TUBE  | <u>POCKETSCOPE</u> |

Also, RAKSCOPES, Linear Amplifiers, RAYONIC tubes and other equipment.



of signals being transmitted, (2) the magnitude of frequency modulation, and (3) error displacement of the signal from assigned center frequency. Designed for 117-v, 60-cycle operation, the unit monitors up to five carrier frequencies in either the 20 to 50-mc or 152 to 174-mc band. Other frequencies may be monitored by exchange of control crystals. These temperature-compensated crystals introduce an error of less than 0.00005 percent.

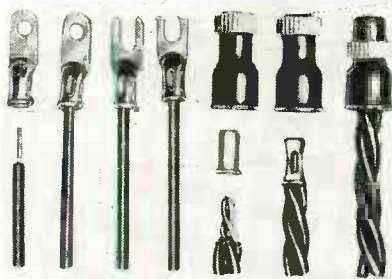

### Solderless Terminal Lug

BUCHANAN ELECTRICAL PRODUCTS CORP., 1290 Central Ave., Hillside, N. J. The new Termend solderless lug can be installed on all wire sizes from No. 16 to No. 8 AWG with a single crimping tool. These features enable considerable economy through allowing purchase, stocking and handling of fewer items. The lugs are available in ring, spade and locking spade-tongue styles.



### Attenuators

KAY ELECTRIC CO., Pine Brook, N. J. Two new attenuators provide low signals and attenuating signals by known amounts, and cover the frequency range of 0 to 500 mc. Model 20 has constant input and output impedance equal to 53.5 ohms and

# TOROIDAL COMPONENTS

## PRECISION TUNED CIRCUITS FOR YOUR SELECTIVE AMPLIFIER



ACTUAL SIZE

High Q precision tuned resonant circuits, accurately adjusted to your specified frequency. Toroid coil and capacitor are permanently protected by tough thermosetting plastic. Pigtail leads and light weight allow direct or terminal board mounting.

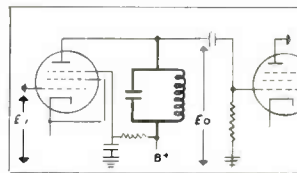

TYPICAL APPLICATION

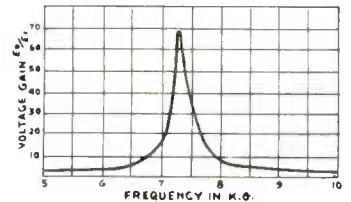

## CUSTOM MADE TOROID COILS

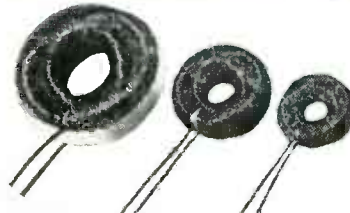

Toroid coils, transformers and discriminators in a large range of inductances, frequencies and power levels. Permalloy dust cores. Uncased, mounted in hermetically sealed cans or coated with thermosetting plastic. Close tolerances with taps at any point. Multiple windings. Up to 2 Henries on wedding ring size. Larger sizes to 50 Henries.

## MINIATURE TOROID FILTERS



1 1/2" x 1 1/4" x 2" HIGH

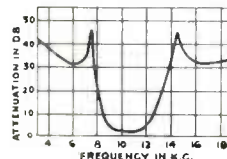

Specialized design and complete production facilities for your filter requirements. Where space is critical, miniature filters with wedding ring toroids and special capacitors. Supplied in standard units, or designed to your specification. A miniature band pass filter and curve are shown.

RAPID PRODUCTION DELIVERY. Engineering requirements given special attention. Wire, phone or write complete specifications.

# COMMUNICATION ACCESSORIES

*Company*

HICKMAN MILLS, MISSOURI

**Bendix-Pacific**

**RELIABLE TELEMETERING**



Bendix-Pacific offers the aircraft industry the fully tested and proven AN/DKT-3 Subminiature Telemetering System.

The complete Telemetering Services offered by Bendix-Pacific include:

1. Application engineering to adapt the Bendix-Pacific System to each specific instrumentation problem.
2. Standard and special FM/FM sub-miniature components and assemblies.
3. Installation engineering and calibration services.
4. Aircraft and missile antenna design.
5. Flight testing, providing ground station facilities and reduction and analysis of data.

Indicative of the engineering leadership which Bendix-Pacific has attained is the fact that a typical six-channel teletesting system complete with power supply weighs 12 pounds and occupies only 130 cubic inches. Equipment now available to provide line of sight ranges up to 100 miles or more for Bendix-Pacific Telemetering Systems. Inquiries from qualified companies and agencies for complete engineering data are invited.

Plug-in components provide the utmost in flexibility for the instrumentation engineers in your company.

TO MEASURE • TO INDICATE • TO WARN ... AT A DISTANCE



**DUAL CONTROL**

- ★ Series 37, linear and tapered resistance, 1000 ohms min. to 5 meg. max.
- ★ Series 43, 10,000 ohms max. linear. Limited tapers available.
- ★ Resistance values within 10% plus/minus, standard, on Type 43. 20% plus/minus on Series 37 under 100,000 ohms. 30% plus/minus over 100,000 ohms (RMA Standard).

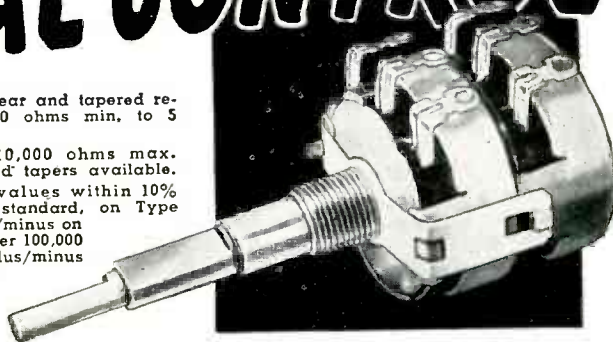

**CONCENTRIC-SHAFT TANDEM**

★ Concentric dual knobs control two independent circuits independently. Typically Clarostat's s-m-o-o-t-h rotation, thanks to centerless-ground concentric shafts. With Series 37

(composition-element) or Series 43 (wire-wound) 1 1/8" dia. controls. With switch if desired. Reinforcement strap for rigid tandem assembly.

WRITE FOR BULLETINS 112 AND 116. LET US QUOTE!

CLAROSTAT



*Controls and Resistors*

CLAROSTAT MFG. CO., INC. • DOVER, NEW HAMPSHIRE • In Canada: CANADIAN MARCONI CO., LTD. Montreal, P. Q., and branches

**Gold-Plated  
TUNGSTEN  
and  
MOLYBDENUM  
GRID WIRE**



Made to meet your specifications... for gold content, diameter and other requirements.

Write for details and list of products

**SIGMUND COHN CORP.**  
44 GOLD ST. NEW YORK

SINCE 1907





model 21 equal to 70 ohms. A fixed insertion loss of 10 db and switchable insertion loss in 1-db steps to a total of 41 db are provided.

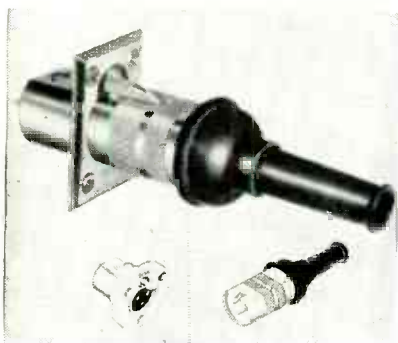

### Audio Connectors

CANNON ELECTRIC, 3209 Humboldt St., Los Angeles 31, Calif. Designed and manufactured to meet RMA standards, the UA series of audio connectors consists of two plugs and four receptacles, carrying three 15-ampere contacts rated at 1,500 volts minimum flashover. Cable entry is  $\frac{1}{2}$  inch. Rubber bushings and cable relief collar protect the connectors from shock and moisture. Bulletin UA-1 is available on request.

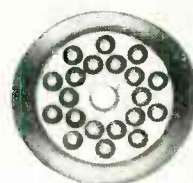

### Ultra-High-Speed Relay

STEVENS-ARNOLD INC., 22 Elkins St., South Boston 27, Mass. The Millisec relay now offered has an operating time as short as  $\frac{1}{3}$  millisecond, is hermetically sealed and is available in 6-pole double-throw construction. Contact rating is 110 volts d-c, 0.5 ampere. Life ex-

# NOW R. F. ATTENUATION NETWORK FOR YOUR WORK

To meet the increasing needs for accurate, dependable instruments to attenuate UHF, The Daven Company now offers RF attenuation boxes. These units are notably compact, provide a wide range of attenuation and are moderately priced.



Series 640

### —SPECIFICATIONS—

CIRCUIT: Pi network.  
 STANDARD IMPEDANCES: 50 and 73 ohms. Other impedances on request.  
 RESISTOR ACCURACY:  $\pm 2\%$  at D. C.  
 IMPEDANCE ACCURACY: Terminal impedance of loss network essentially flat from 0—225 MC.  
 RECEPTACLES: A/N Types UG-58/U or UG-185/U.  
 CABLE PLUGS: May be secured at additional cost.  
 NO. OF STEPS: Types: 640, 641, 642, 643 ..... 8 Push Buttons  
 Types: 650 and 651 ..... 10 Push Buttons

SERIES	IMPEDANCE	RANGE
640 & 641	50 $\Omega$ or 73 $\Omega$	80 Db Total in 1 Db Steps
642 & 643	50 $\Omega$ or 73 $\Omega$	100 DB Total in 2 DB Steps
650 & 651	50 $\Omega$ or 73 $\Omega$	100 DB Total in 1 DB Steps

### —APPLICATIONS—

- In signal and sweep generators.
- In field strength measuring equipment.
- Nucleonic and atomic research.
- Television receiver testing.
- Wide-band amplifiers.
- Pulse amplifiers.
- Any application where attenuation of UHF is required.

For Additional Information Write to Dept. E-1

"DAVEN—one of "Electronics!" charter advertisers 20 years ago congratulates "ELECTRONICS" on its 20th anniversary."

THE **DAVEN** CO.

191 CENTRAL AVENUE  
 NEWARK 4, NEW JERSEY

*Announcing!*

# The FURST WIDE BAND D. C. AMPLIFIER MODEL 120

A precision instrument designed for use as a preamplifier in conjunction with an oscilloscope, vacuum tube voltmeter or other instruments.

## SPECIFICATIONS

**Frequency Response:** Within  $\pm 1$  db (or better) between D.C. and 100,000 cycles per second.

**Gain:** Approximately 100.

**Input Connection:** Double channel, can be used for single ended and push-pull signals or as a differential amplifier.

**Input Impedance:** One Megohm shunted by approximately 15mmf in each channel.

**Dual input Attenuator:** One to one, 10 to one, 100 to one and "off" positions in each channel independently adjustable.

**Output Connection:** Push-pull or single ended.

**Output Impedance:** Less than 50 Ohms single ended or 100 Ohms push-pull.

**Hum and Noise Level:** Below 40 Microvolts referred to input.

**Low Drift** due to operation of heaters of input stage from regulated D.C. power ( $\pm 1$  Millivolt) referred to input.

**Mounting:** Metal cabinet approximately 7" wide by 7" high by 11" deep.



## SPECIALISTS IN ELECTRONIC GEARS

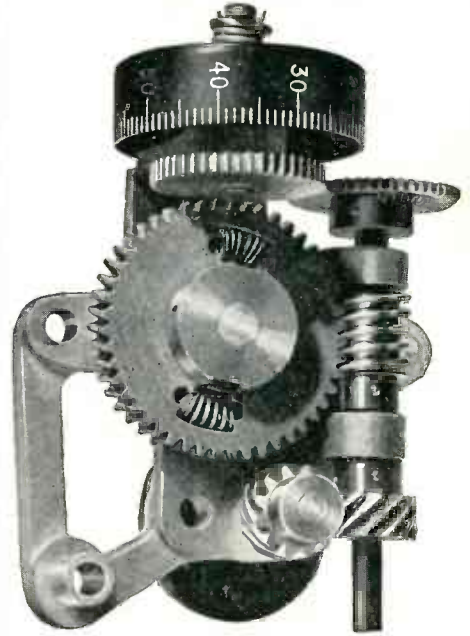

## QUAKER CITY GEAR WORKS

1910 N. FRONT ST.  
PHILADELPHIA 22, PA.



## FURST ELECTRONICS

10 S. Jefferson St., Chicago 6, Illinois

time saving...  
cost saving!

dependable instruments

*Heiland*  
DENVER



Type  
A-708  
24-channel

### SPECIAL FEATURES

- Easy loading
- Four quick-change paper speeds
- Simultaneous viewing, recording, scanning
- Trace identification
- Zero mirror
- Adjustable automatic record length
- Synchronizing reference trace
- Lamp burn-out indicators
- Size: 9 $\frac{5}{8}$ " (H) x 13 $\frac{1}{4}$ " (L) x 19 $\frac{1}{8}$ " (D)
- Weight: 59 lbs.

## AUTOMATIC OSCILLOGRAPH Recorder

Developed for simplicity and ease of operation, the HEILAND Automatic Oscillograph Recorder saves time... reduces costs. Flexibility of operation permits the recording of strain, vibration, pressure, acceleration and temperatures.

Write for complete detailed information

**HEILAND RESEARCH CORPORATION**  
137 East Fifth Avenue Denver, Colorado

## Working with Inert Gases?

*Linde* HELIUM · NEON  
ARGON · KRYPTON · XENON

Now available in commercial-size cylinders in addition to glass bulbs. Write for information on sizes, prices, rigid purity tolerances, special rare gas mixtures...

### THE LINDE AIR PRODUCTS COMPANY

Unit of Union Carbide and Carbon Corporation  
30 East 42nd Street New York 17, N. Y.  
In Canada: Dominion Oxygen Company, Limited, Toronto

The term "Linde" is a registered trade-mark of The Linde Air Products Company.



pectancy varies from 22 million operations at 0.5 ampere to about 100 million operations at 0.25 ampere.



### Electrolytic Capacitors

SPRAGUE ELECTRIC Co., North Adams, Mass. Type All 115-volt electrolytic capacitors for continuous duty a-c service are ideally suited for across-the-line power factor improvement at low voltages, particularly with appliances and light industrial equipment. They are also useful in applications where a voltage drop is required without power dissipation. Engineering bulletin 301, giving complete standard ratings, is available.

### Literature

**X-Ray Apparatus.** Picker X-Ray Corp., Waite Mfg. Division, 17325 Euclid Ave., Cleveland 12, Ohio. A recent 32-page booklet illustrates and describes a wide variety of all-purpose x-ray apparatus. Included are the Century 100-ma self-rectified single-tube radiographic-fluoroscopic unit with monitor control; and the 200-ma full-wave two-tube radiographic and fluoroscopic diagnostic unit with Pictronic control.

**Ignitron Substations.** Westinghouse Electric Corp., P. O. Box 2099, Pittsburgh 30, Pa. A 16-page booklet, B-4239, treats of ignitron unit substations. The substations described provide a source of d-c power near the load directly within the mine or factory building and are being applied to

# Timing Ideas

## PRECISION PERFORMANCE



Manufacturers, recognizing that components of quality insure outstanding product performance, look to Haydon® at Torrington for timers and timing devices. All Haydon timers are made with the same precision as the Haydon motor — your guarantee of satisfactory performance. If you need a special design, you'll find Haydon's extensive engineering and development facilities without equal for service and results.

A few examples of basic Haydon timing units are featured below.

### SERIES 8010 INTERVAL TIMER WITH BUZZER

Compact, low cost timer for volume production. Wide range of intervals. Audible (buzzer) signal optional. Quick break. Load contact rated 10A, ½ HP 250 VAC.



### SERIES 8006 INTERVAL TIMER

Designed for heavy duty, this unit is available in quantities in standard models. Wide range of intervals. HOLD feature optional. Quick break. Totally enclosed. Switch rated 28A, 1 HP 250 VAC.



### SERIES 5900 TIME DELAY RELAY

For use where positive, accurate time delay relay is imperative. Automatic reset. Fixed models for volume production; adjustable models in 4 delay ranges for general use.

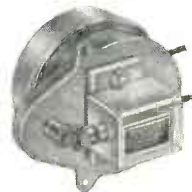

Ⓢ TRADE MARK REG. U.S. PAT. OFF.

For complete design and engineering specifications, write for catalog: Timing Motors No. 322 — Timers No. 323 — Clock Movements No. 324. Yours without obligation.

### SERIES 5700 ELAPSED TIME INDICATOR

Synchronous timing motors with cyclometer type counters for metering elapsed time. Rugged models for wide range of timing, recording operations; in several registers, resettable or non-resettable.



**HAYDON**  
AT TORRINGTON

HEADQUARTERS FOR  
**TIMING**

**HAYDON Manufacturing Co., Inc.**  
2428 ELM STREET

TORRINGTON, CONNECTICUT

SUBSIDIARY OF GENERAL TIME CORPORATION

# SPECIALISTS

IN TUNING FORK FREQUENCY STANDARDS



PHILAMON LABORATORIES manufacture *temperature-compensated, hermetically-sealed* tuning fork resonators in fundamental frequencies from 1,000 to 3,000 cycles per second — and in accuracies from 1 part in 3,000 to 1 part in 100,000. Accuracies up to 1 part in 20,000 are obtainable for operation over temperature ranges as wide as 100 Degrees Centigrade without benefit of oven control.

Insensitive to atmospheric and relative humidity variations — the resonators are available individually — as a part of compact sub-assemblies — or in completely engineered equipment.

## PHILAMON *Laboratories*

5717 THIRD AVENUE BROOKLYN 20, NEW YORK



For  
Advanced  
RELAYS  
specify  
**ADVANCE**

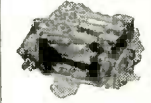

RELAYS for general circuit control, electronic, aircraft and marine applications. Crisp action, dependable and durable. ADVANCE offers sensitive, midget, telephone, keying, instrument, time-delay, overload, transmission line, impulse, hermetically sealed, and ceramic insulated relays. Wide variations of these types for special applications and special relays made to specifications.

ADVANCE'S engineering ability and manufacturing facilities will assist in engineering problems and supply special relays for the most exacting requirements. Your inquiry will receive prompt and courteous attention.



ADVANCE ELECTRIC & RELAY CO.  
2435 North Naomi Street ★ Burbank, California

FOR ORIGINALITY

LOOK TO **XCELITE**

Have Your Dealer Show You This Set  
In UNBREAKABLE Transparent Box!

- 3 fast-change double-end screwdrivers (3 regular, 3 Phillips) for only **\$3.95!**
- MAN-SIZE XCELITE handle fits all blades!
- A REAL SAVING over buying individual screwdrivers!
- Box of Transparent plastic good for plenty of punishment!
- You can also buy XCELITE reamers to fit same handle—and save money!

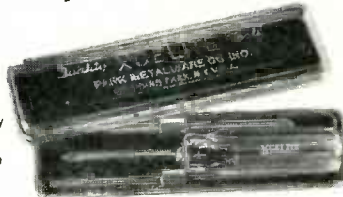

PARK METALWARE CO., INC.

Dept. C

Orchard Park, N. Y.

Canadians Send Orders Direct to: Chas. W. Pointon, Canadian Warehouse Distributor, 1926 Gerrard St., E., Toronto, Ont.

For Precision Washers... For Precision Stampings...

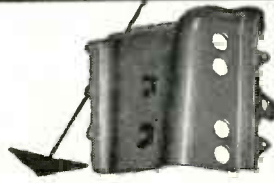
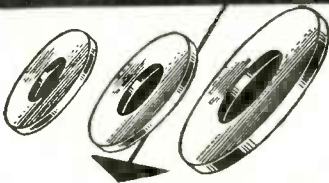

## WHITEHEAD STAMPING CO.

A preferred source of precision-made WASHERS and STAMPINGS. 46 years of experience and up-to-the-minute facilities, assure highest quality and service.



EST. 1903

## WHITEHEAD STAMPING CO.

1691 W. Lafayette Blvd.

Detroit 16, Michigan

INSURE  
*Proven Quality*  
with **JONES**

## PLUGS & SOCKETS

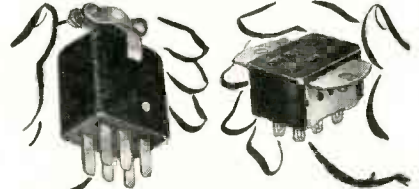

P-306-CCT — Plug,  
Cable Clamp in cap.

S-306-AB — Socket  
with Angle Brackets.

Series 300 Small Plugs & Sockets  
for 1001 Uses

Made in 2 to 33 contacts for 45 volts, 5 amps, for cap or panel mounting. Higher ratings where circuits permit. All plugs and sockets polarized. Knife switch socket contacts phosphor bronze, cadmium plated. Engage both sides of flat plug—double contact area. Bar type plug contacts hard brass cadmium plated. Body molded bakelite.

Get full details in Catalog 17. Complete Jones line of Electrical Connecting Devices, Plugs, Sockets, Terminal Strips. Write today.



HOWARD B. JONES DIVISION  
CINCH MANUFACTURING CORPORATION  
CHICAGO 24, ILLINOIS  
SUBSIDIARY OF UNITED-CARR FASTENER CORP.



railway, mining, electrochemical, general industrial and other specialized fields.

**Special Purpose Motors.** Eastern Air Devices, Inc., 130 Flatbush Ave., Brooklyn 17, N. Y., has made a 17-page catalog of a collection of bulletins dealing with subfractional h-p motors, synchronous motors, military motors and blowers. Illustrated descriptions, performance specifications and performance curves are included.

**Capacitors.** The Allen D. Cardwell Mfg. Corp., Plainville, Conn. Catalog No. 50 is a 24-page treatment of a wide line of variable and fixed air capacitors. Illustrations, general specifications and dimensional drawings for all are given. An insert is also included giving list prices for the various types.

**UHF Impedance Measurements.** Hewlett-Packard Co., 395 Page Mill Road, Palo Alto, Calif. Volume 1, No. 5 of the Journal devotes its 4 pages to a description of how an accurate slotted line section is an effective aid in the determination of impedance or investigation of impedance mismatch and power wastage at ultrahigh frequencies. Specifications for two models of slotted lines and one standing-wave indicator are given.

**Speakers.** Oxford Electric Corp., 3911 S. Michigan Ave., Chicago, Ill. A new 4-page catalog gives complete listings and pertinent data on a line of speakers, along with illustrations of several types. The line described includes the following types: electrodynamic, permanent magnet, television, public address, auto, intercom and weather proof speakers.

**Marine Radar.** Westinghouse Electric Corp., Baltimore, Md. An eight-page bulletin covers the type MU-1 marine radar with specialized design which incorporates all of the features necessary to meet operational requirements. Features of the radar described include a 12½-in. flat-face scope, a complete system check, one-mile range,

# V.H.F. PUSH BUTTON ATTENUATOR



## True V.H.F. loss measurement at last!

An outstanding development which in the first year of production has fully established itself with leading British communication organisations and remains the first and only accurate instrument of its kind.

### Two models available

Type 74600 - A : 0-9 db in 1 db steps

Type 74600 - B : 0-90 db in 10 db steps

Both have a 75 -ohm characteristic impedance and will handle inputs up to 0.25 watts.

### 50 Mc/s Performance \*

MODEL	VARIATION BETWEEN 50 Mc/s and D.C.	ACCURACY OF D.C. ADJUSTMENT
0 - 9 db	<± 0.01 db per step	± 0.05 db at all settings
0 - 90 db	<± 0.1 db per step	± 0.03 db per step

\* Insertion loss relative to zero setting

### Ready for building into your own equipment

Calibration charts for frequencies up to 100 Mc/s for the 0-9 db model or 60 Mc/s for the 0-90 db model can be supplied on request.

### Standard Telephones and Cables Limited

An I. T. & T. Associate

TRANSMISSION DIVISION, NORTH WOOLWICH, LONDON, ENGLAND

# LITTELFUSES

"Quicker than a short-circuit"

Used Everywhere for  
Delicate Equipment  
**PROTECTION**

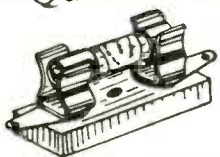

Galvanometers    Microammeters  
Milliammeters    Radio Tubes, etc.

Stock sizes 1/32, 1/16, 1/8, 1/4, 1/2, 1 and 2 Amps.  
Convenient Mountings.

WRITE NOW!

**LITTELFUSE LABORATORIES**  
1772 Wilson Avenue, Chicago, Illinois

**20 YEARS AGO...this**  
advertisement in *Electronics* brought  
us our first order! Today **90%** of  
all television receivers are **LITTELFUSE**  
equipped . . . **LITTELFUSE INC.**

4769 N. RAVENSWOOD AVENUE, CHICAGO 40, ILLINOIS

• Compare for results!  
• Compare for price!  
• and you'll choose  
the **GREEN ENGRAVER**



only \$215\*

. . . anybody with  
a hand can operate it!

The Green Engraver offers great speed and convenience. Quickly cuts up to four lines of letters from 3/64" to 1" on curved or flat surfaces whether made of metal, plastics or wood . . . operates by merely tracing master copy—*anyone* can do an expert job. Special attachments and engineering service available for production work. Just the thing for radio, electronic apparatus and instrument manufacturers.

For quality engraving on

- Panels • Name Plates • Scales
- Dials • Lenses • Molds • Instruments

. . . also does routing, profiling and three dimensional modeling.

\*Price does not include master type and special work holding fixtures.

**GREEN**

**GREEN INSTRUMENT CO.**  
363 Putnam Ave.  
Cambridge, Mass.

## PHOTOVOLT VIDEO

Brightness Tester  
MOD. 205



A photoelectric instrument for measuring the brightness of television tubes and screens in foot-lamberts.

Price, \$68

Write for literature to  
**PHOTOVOLT CORP.**  
95 Madison Ave., New York 16, N. Y.  
Photoelectric and  
Electronic Measuring Instruments

## CAPITOL RADIO ENGINEERING INSTITUTE

Pioneer in Radio Engineering Instruction Since 1927

An Accredited Technical Institute

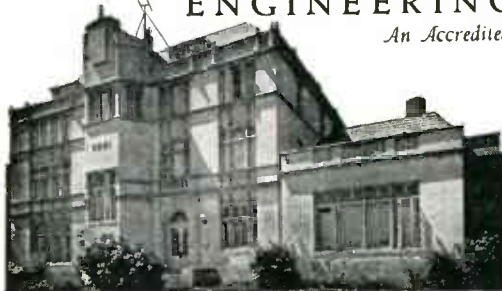

ADVANCED HOME STUDY  
AND RESIDENCE COURSES IN  
PRACTICAL RADIO-ELECTRONICS  
AND TELEVISION ENGINEERING

Request your free home study or  
resident school catalog by writing to:

DEPT. 284B

16th and PARK ROAD, N.W.  
WASHINGTON 10, D.C.  
Approved for Veteran Training



Write today for  
further information.  
\$240 F.O.B. Portland

### NEW EXTENDED RANGE Model 250-B IMPEDANCE BRIDGE

TEN TIMES THE RANGE

Resistance: 1 milliohm to 11 megohms.  
Capacitance: 1 mmd. to 1100 mfd.  
Inductance: 1 microhenry to 1100 henrys.

TWICE THE ACCURACY

Better than 1/2% on most measurements.

MANY TIMES THE CONVENIENCE

Simplified switching — Colored indexed dials — Unique  
direct reading LRC dial — No AC power connection re-  
quired — Lightweight, 15 lbs. — Compact, 9 1/2" x  
10 1/4" x 10 1/2". Accessory null amplifiers available.

Of Previous Instruments In Its Price Range

**BECO**

**BROWN ELECTRO-MEASUREMENT CORPORATION**

Successor to Brown Engineering Co.

4635-37 S. E. HAWTHORNE BOULEVARD

PORTLAND 15, OREGON



improved sea suppression and centralized control. Installation information and mechanical and electrical characteristics are given.

**TV Viewing Tubes.** Sylvania Electric Products Inc., Emporium, Pa., has published a 20-page booklet providing television picture tube and general purpose c-r tube characteristics, replacement tube data, base diagrams, suggestions for tube handling, and a concise description of c-r oscilloscope use in tv servicing. Information contained covers 165 tube types with faces ranging from 2 to 20 inches maximum dimension utilizing electrostatic or magnetic deflection systems.

**Ovens for Electronic Industry.** Steiner-Ives Co., 8-16 Ave. L, Newark 5, N. J., recently issued a four-page folder dealing with ovens for the processing of c-r and vacuum tubes for the electronic industry. It illustrates units designed for special jobs, concerning which further information is available.

**Mass Spectrometer Leak Detector.** Vacuum-Electronic Engineering Co., 316 37th St., Brooklyn 32, N. Y. Bulletin LD-6 describes typical applications of the model MS-2 mass spectrometer leak detector for use wherever a vacuum, fixed pressure or special atmosphere must be maintained for extended periods of time. Principle of operation, features and pertinent data pertaining to vacuum testing and pressure testing are given with explanatory illustrations.

**Magnetic Amplifier Design.** Vickers Electric Division, 1815 Locust St., St. Louis 3, Mo., has issued a collection of bulletins in a loose-leaf bound handbook dealing with magnetic amplifier design. Applications, technical data, performance characteristics and ratings are given in 44 well-illustrated pages.

**Laboratory Standards.** Measurements Corp., Boonton, N. J. Catalog C is a 44-page booklet presenting a line of standard signal

# SOUND POWERED HANDSETS

## \$12<sup>95</sup>

PER PAIR

Complete with  
6-Foot Cord



## Famous Navy Units

*Operates without batteries!  
No electricity needed!  
Practically no installation  
— just hook up with a pair of wires.*

### PRACTICAL USES EVERYWHERE— Ideal for

Television antenna adjustment

Kitchen to garage

House to barn, workshop or field

Boats

Camps

Construction jobs

Office intercommunication

**HUNDREDS OF OTHER USES!**



PRICE ONLY **\$12<sup>95</sup>** per pair

25% with order — balance c.o.d.  
plus postage. Remit in full and  
save postage and c.o.d. charges.

## WESTERN ELECTRONIC CO.

2791 Shattuck Ave.

Berkeley 5, California

Phone: Berkeley 7-7038

*Designed for*



*Application*

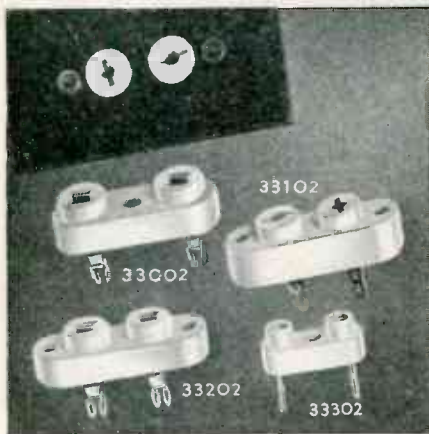

**Crystal Holder Sockets  
33002, 33102, and 33202  
Plus new 33302 for CR7**

In addition to the original 33002, 33102 and 33202 exclusive Millen "Designed for Application" steatite crystal holder sockets, there is now also available the new 33302 for the new CR7 holder. Essential data:

Type	Pin Dia.	Pin Spacing
33002.....	.125	.750
33102.....	.095	.500
33202.....	.125	.500
33302.....	.050	.500

**JAMES MILLEN  
MFG. CO., INC.**

MAIN OFFICE AND FACTORY  
**MALDEN  
MASSACHUSETTS**



NEW PRODUCTS

(continued)

generators, television signal generators, pulse generators, square-wave generators, megacycle meters, vacuum-tube voltmeters and other laboratory standards.

**House Organ.** Measurements Corp., Boonton, N. J. The first issue of Measurements Notes is a 4-page illustrated brochure describing the use of the model 59 megacycle meter in the design and construction of traps and filters for the elimination of television interference.

**Timing Devices.** Muirhead & Co., Ltd., Beckenham, Kent, England. Four types of phonic motor timing devices are covered in the single-sheet bulletin B-601-C. An illustrated description and overall dimensions of each unit are given. More minute details of the motors may be found in bulletin B-615.

**Transformer Catalog.** Peerless Electrical Products Division, Altec Lansing Corp., 161 Sixth Ave., New York 13, N. Y., has published a new transformer catalog containing new models and including a complete line of transformers for broadcasting and other professional applications as well as for amplifier constructors, audio enthusiasts, the replacement field and hams. The line includes output, input, interstage, plate and filament, power smoothing and swinging chokes, modulation and replacement types.

**Electrical Insulation Price Catalog.** Insulation Manufacturers Corp., 565 West Washington Blvd., Chicago 6, Ill., is offering the 128-page price catalog No. 14, giving complete price information on electrical insulating materials. Divided into 13 sections for quick reference, it covers a variety of materials including tapes, tubings and sleeveings, varnished cloths, mica, papers, wedges, plastics, vulcanized fibre, cordage, varnishes and numerous other products.

**TV Replacement Guide.** Merit Transformer Corp., 4425 N. Clark St., Chicago 40, Ill., announces its 1950 television replacement guide, listing approximately 400 popular

**ARE  
YOU SURE  
YOU ARE  
USING  
THE MOST  
EFFICIENT**

*Electrical  
Paper*

**FOR YOUR  
JOB?**

We are specialists in  
Electrical Papers — Let  
our laboratories analyze  
your requirements.

**SEND FOR**

Free Booklet  
"Industrial  
Paper — The  
New Produc-  
tion Answer."

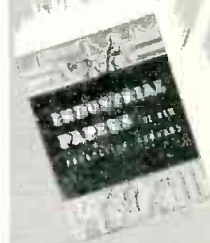

REG. U. S.

PAT. OFF.

**CENTRAL PAPER COMPANY  
INCORPORATED**

2442 LAKESHORE DRIVE, MUSKEGON, MICH.



# BIRTCHEr

STAINLESS STEEL - LOCKING TYPE

## TUBE CLAMPS

Stainless Steel

Corrosion Proof



### 83 VARIATIONS

Where vibration is a problem, Birtcher Locking TUBE CLAMPS offer a foolproof, practical solution. Recommended for all types of tubes and similar plug-in components.

**More than three million of these clamps in use.**

### FREE CATALOG

Send for samples of Birtcher stainless steel tube clamps and our standard catalog listing tube base types, recommended clamp designs, and price list.

**THE BIRTCHEr CORPORATION**  
5087 HUNTINGTON DR. LOS ANGELES 32

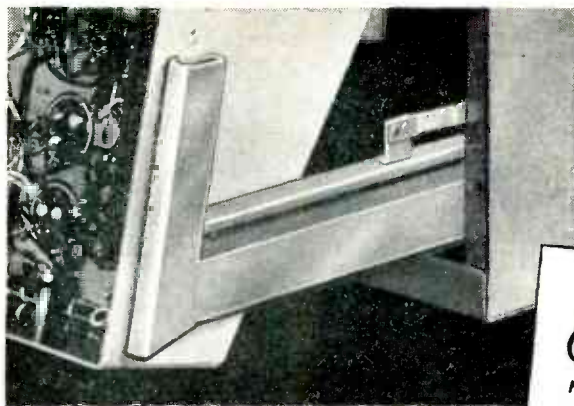

Try Remler for Service-Tested "Hard-to-Get" Components

## Custom Components

Metal-plastic components designed and manufactured to order. Write for quotations specifying electrical and mechanical characteristics. Describe application. No obligation.

FOR EFFICIENT MAINTENANCE

## SPECIFY REMLER TILT-UP EQUIPMENT SLIDES

Remler slide rails for rack or cabinet mounting permit complete withdrawal or inspection of top and bottom of apparatus chassis. Positive . . . self-locking. Full roller type . . . handles equipment up to 50 lbs. Stainless steel for

military applications; cadmium plated cold rolled steel or bonderized cold rolled steel. Nickel plated brass rollers; roller studs in stainless or copper flashed cold rolled steel.

Remler Company Ltd. 2101 Bryant St. San Francisco 10, Calif.

# Remler

Since 1918 PIONEERS IN ELECTRONICS AND PLASTICS



CHICAGO  
NAVY PIER

MARCH 28-31, 1950

For designers, production men, sales executives, merchandise men and buyers in all industries and businesses. See all the latest advances in the world of plastics. See how to use plastics in all forms, old and new — to stimulate the sale of *your* products. Over 100 exhibits — materials, machines, finished products. Consult with the experts—they'll be there!

**Guest Tickets:** Exposition not open to public. Free guest tickets are available by writing (on your company letterhead) to

**THE SOCIETY OF THE PLASTICS INDUSTRY, INC.**  
295 MADISON AVENUE, NEW YORK 17, N. Y.

## CONTINENTAL NOBLELOY METAL FILM

### NF RESISTOR

**NEW**



- Low Temperature Coefficient
- Range; 1 Ohm to 1 Megohm
- Axial Leads; 1/2 Watt
- Small Size 1/2" long x .150" Dia.
- Tolerance + — 1% & 5%

Continental type NF "Nobleloy" resistors were designed to meet the needs of miniature, stable, precision resistors in critical applications.

Write for further details

**CONTINENTAL CARBON INC.** CLEVELAND 11, OHIO

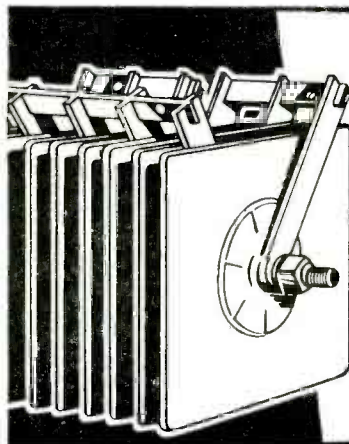

## SELENIUM RECTIFIERS

Output Ratings: 1 ma. to 10,000 amp. and 5000 v. Available in 10 standard cell sizes. Unsurpassed performance. Now serving leading national manufacturers of DC Conversion Equipment. Prompt delivery. Write for your copy of "Rectifier News."

### INTERNATIONAL RECTIFIER CORPORATION

6809 S. Victoria Ave.  
Los Angeles 43, Calif.

B		1 1/2" x 1 1/2"
C		1 1/2" x 1 1/2"
D		3" x 3"
E		4 3/4" x 4 3/4"
F		5" x 6"
H		6 1/2" x 7 1/4"

Functionally  
**PACKAGED**  
 Electronics

the *mecha*  
**MINI-CHOPPER**  
PATENT PENDING



Servomechanisms, Inc.  
 Announces the  
**MINI-CHOPPER**

- A precision miniature device for use in
- Modulation . . .
  - Demodulation . . .
  - Rectification . . .
  - Inversion . . .
- The ultimate in miniature functional packaging combining the maximum in
- Performance . . .
  - Stability . . .
  - Dependability . . .

INFORMATION FOR SPECIFIC APPLICATIONS ON REQUEST.

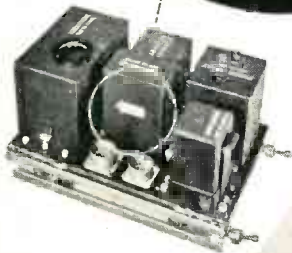

Designers and Producers of precision electronic devices for military and commercial application.

NEW PRODUCTS

(continued)

television receiving sets made by 60 manufacturers. The guide is intended to cut repair-bench time by providing a simple, quick method of determining the correct replacement parts.

**Insulation Testers.** James G. Biddle Co., 1316 Arch St., Philadelphia 7, Pa. Two new models of the Meg type instruments for laboratory, production and other repetitive field tests of insulation resistance are described and illustrated in bulletin 21-46. Applications, electrical circuit diagrams and specifications are included.

**Antenna Stacking Information.** Technical Appliance Corp., Sherburne, N. Y. Explanation and detailed drawings of the proper procedure in stacking highband antennas are found in engineering bulletin No. 58. Dimensions and proper phasing of antennas are given for providing maximum signal strength with both the two-stacked arrays and four-stacked arrays.

**Slotted Line.** Federal Telecommunication Laboratories, Inc., 500 Washington Ave., Nutley 10, N. J. The FTL-30A slotted line, a precision device designed for making impedance and wave length measurements in the 60 to 1,000-mc range, is covered in a single-sheet bulletin. General description, special design features, characteristics and accessories required are outlined.

**Resistor Catalog.** Cinema Engineering Co., Burbank, Calif., has issued catalog 11AX in three colors, 36 pages, with charts, tables, photographs, diagrams and schematic drawings of precision wire wound resistors, resistive devices and sound equipment. It is supplementary to the general catalog and includes more than a score of new items with description and prices.

**Audio Equipment.** Sun Radio & Electronics Co., Inc., 122 Duane St., New York 7, N. Y., has issued a handbook dealing with radio a-m and f-m tuners, phonograph pick-

this complex shape is being made at low cost by ...



actual size

## Cold Heading

This special steel stud, used in heavy duty power transmission equipment, combines two different shapes with four diameters.

*Some of the steps involved in cold heading this part from a length of steel wire. (Shown one-half actual size.)*

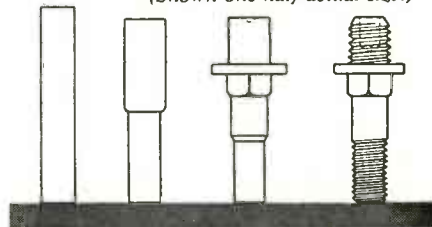

Production of this steel part by ordinary methods would involve the use of high cost machines, plus other costly operations. Cold heading not only provides economy and speed of production, but also produces a much stronger part.

Possibly this special technique can help you with your fastener problems. Send your sample or blueprint to Scovill first.

"Guide to the Profitable Use of Cold Heading"—Bulletin No. 2 describes the advantages and limitations of this process. It's free for the asking.

A PRODUCT OF

Recessed Head Screws • Sems  
 Tapping Screws • Standard  
 Machine Screws • Special Cold  
 Headed Parts

**SCOVILL** FASTENERS AND SPECIAL PARTS

Industrial Fastener Sales, Waterville Division  
 Scovill Manufacturing Co., Waterville 14, Conn.

New York • Detroit • Wheaton, Ill.  
 Los Angeles • Cleveland • San Francisco



THIS FEATHERWEIGHT WILL  
**LICK  
SOLDERING  
FATIGUE!**

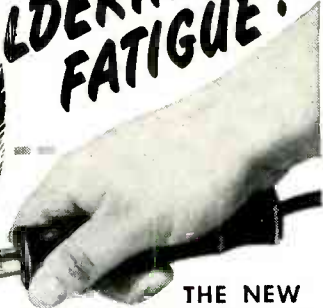

THE NEW  
**HEXACON  
BANTAM  
MODEL 30H**

Weight—5½ Ounces • Watts—  
40 or 60 • Tip Dia.—Both ⅛" and ¼" Tips  
Furnished with Each Iron • Price—\$5.00

So light its weight is hardly noticeable. Out-  
performs any iron of equal size. Hatchet de-  
sign makes it more comfortable and practical  
to use than a pencil iron. No transformer re-  
quired. Write for complete catalog.



**HEXACON ELECTRIC CO.**  
130 WEST CLAY AVE., ROSELLE PARK, N. J.

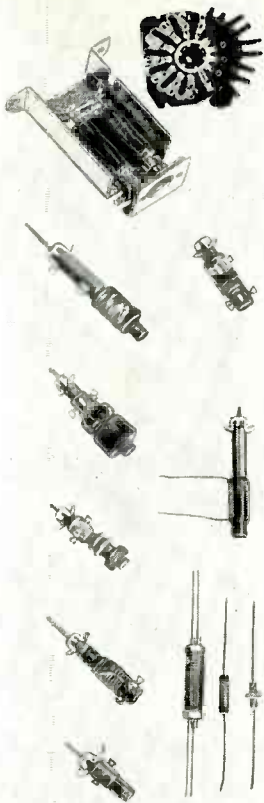

**Are COILS Your  
BOTTLENECK?**

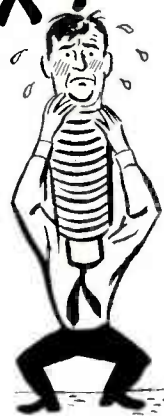

Is the manufacture of R.F. Coils a "step-  
child" operation in your plant? Does it  
lead to snarled-up production because  
of inadequate facilities and endless  
engineering detail? If so, Clippard In-  
strument Laboratory can help you out in  
a hurry!

Now at your disposal is efficient new  
high-speed coil winding equipment of  
our own design, plus a staff of produc-  
tion and control technicians schooled in  
laboratory accuracy. We deliver the  
quality coils and sub-assemblies you  
want when you want them with a minimum of rejects, fuss and  
bother.

Call on us, like many of the biggest names in radio and television today,  
to free your production facilities for more important  
work. For intelligent help and a prompt quotation, mail your  
requirements, now, to Department 2-E.

**Clippard**

**INSTRUMENT LABORATORY, INC.**

1125 Bank Street Cincinnati 14, Ohio  
MANUFACTURERS OF R. F. COILS  
AND ELECTRONIC EQUIPMENT

ELECTRONICALLY REGULATED  
**LABORATORY  
POWER SUPPLIES**



• STABLE  
• DEPENDABLE  
• MODERATELY  
PRICED

MODEL 28  
STANDARD  
RACK  
MOUNTING  
PANEL SIZE  
5¼" x 19"  
WEIGHT 16 LBS.

- **INPUT:** 105 to 125 VAC, 50-60 cy
- **OUTPUT #1:** 200 to 325 Volts DC at 100 ma regulated
- **OUTPUT #2:** 6.3 Volts AC CT at 3A unregulated
- **RIPPLE OUTPUT:** Less than 10 millivolts rms

For complete information write for Bulletin



**LAMBDA ELECTRONICS**  
CORPORATION  
CORONA NEW YORK

**NEW! 10 MC BANDWIDTH HIGH GAIN OSCILLOSCOPE**

TOP PERFORMANCE FOR \$279.50

Laboratories—Industry—Broadcasters . . .

**AT LAST! an engineer's scope built by engineers for you.**

- ★ Y-AXIS: 10 mv rms/in; 10 cps, 10% tilt; —3 db at 10 MC.
- ★ SWEEPS: 10 cps to 50 KC; recurrent and driven, expansion 5x full scale.
- ★ SUP1—Int. Calibrator—Int. 60~ Phase Shifter—40 lbs. —13 x 8 x 17"

Write TODAY for full data. See it at Booth 330-IRE Show.



**TELEVISION EQUIPMENT CORP.**  
238 WILLIAM ST. • NEW YORK 7, N. Y.

IN CANADA: The Ahearn & Soper Co., Ltd., Ottawa

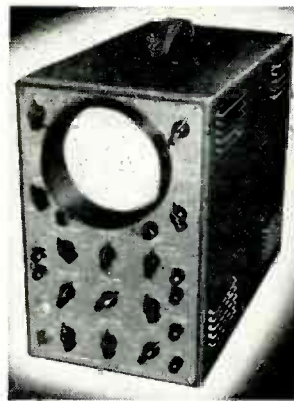

**Little thought-of facts about capacitors**

The short time breakdown voltage of a well-made D.C. capacitor is not less than 5 to 6 times the actual working voltage at 20°—

$$E = 5 \times e \text{ min}$$

$$E = \text{Breakdown voltage}$$

$$e = \text{Rated d.c. working voltage}$$

INDUSTRIAL CAPACITORS are unvaryingly held to this formula.

Designed for maximum safety factor and the smallest possible volume, INDUSTRIAL CAPACITORS are the most widely used capacitor in industrial applications.

WRITE TODAY FOR DETAILED CATALOG

**INDUSTRIAL CONDENSER CORP.**



Watch this space for other capacitor facts that will help you.

Sales Offices in  
All Principal Cities  
3243 N. California Ave.  
Chicago 18, Illinois

# NOTHELPER

## Special TRANSFORMERS



Proven by  
Past  
Performance

Over 25 years' experience in the manufacture of special transformers to meet individual requirements. Built in quality proved by years of actual use.

From 10 VA to 300 KVA Dry-Type only. Both Open and Encased. 1, 2, and 3 Phase. 15 to 400 cycles.

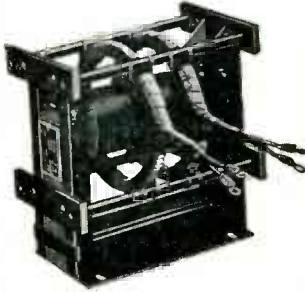

Send for NEW 8 page BULLETIN



### NOTHELPER

WINDING LABORATORIES

9 ALBEMARLE AVE., TRENTON 3, N. J.



ups, records, amplifiers and speakers, and also with the installation of such equipment.

**Millisecond Timer.** Herman H. Sticht Co., Inc., 27 Park Place, New York, N. Y. Bulletin 1030 devotes four pages to an illustrated description of the Chronotest electronic millisecond timer, an instrument designed for measuring short time intervals between 0.1 and 10,000 milliseconds with an accuracy of 1 to 2 percent. Principles of operation and methods of application are included.

**Resistance Percentage Bridge.** Specialties, Inc., Skunks Misery Road, Syosset, N. Y. Brochure S142 illustrates and describes operation of a resistance percentage bridge having an accuracy of 0.01 percent throughout its range of indication. The instrument described is used for quick, accurate calibration of high-precision potentiometers.

**High-Temperature Capacitor.** Pyramid Electric Co., 155 Oxford St., Paterson, N. J. A recent catalog sheet announces the new Humidi-Seal type 85TOC capacitor for high-temperature applications. Outstanding features and specifications are given.

**Circuit Panel.** Kepco Laboratories, Inc., 149-14 41st Ave., Flushing, N. Y. A four-page folder contains complete information on the model 104 circuit panel for experimental electronics. The unit described consists of the panel, 27 keyed circuit diagrams, 3 keyed master charts, 12 blank keyed sheets and one keyed protective diagram cover.

**Vibration Test Stands.** L. A. B. Corp., 31 Union Pl., Summit, N. J. Types RVCG and RVCA two-dimensional, reaction-type vibration test stands are covered in a four-page bulletin. An illustrated description, dimensions and specifications are included.

**Selenium Rectifiers.** Seletron Division of Radio Receptor Co., Inc., 251 W. 19th St., New York 11, N. Y., has prepared a 6-page pam-

# VERSATILITY + ACCURACY

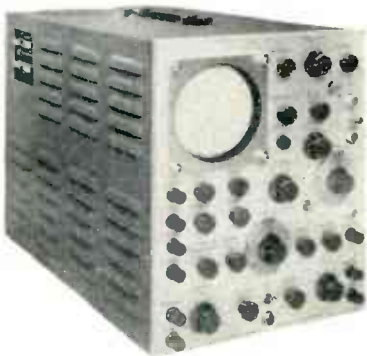

**VERSATILE . . .** The **Tektronix Type 512** Oscilloscope is capable of meeting most requirements in the varied fields of SONAR, RADAR, GEOPHYSICS and BIOPHYSICS. With a vertical amplifier band width of DC to 2 mc and sweep speed range from .3 sec/cm to 3 microsec/cm the observation of either low or high speed phenomena is readily accomplished.

Price \$950 f.o.b. Portland, Oregon

**ACCURATE . . .** In addition to waveform observation, the **Type 512** provides direct reading quantitative measurements. Precision components and stabilized circuits permit the use of approximately 50 inches of scale on both time and amplitude dials, giving accuracies of 5% or better at all points.

**DIFFERENTIAL INPUT • DELAYED TRIGGER • SWEEP MAGNIFICATION**

Please write or wire for complete specifications.



**TEKTRONIX, INC.**

Cables, Tektronix  
712 S. E. Hawthorne Blvd. Portland 14, Ore.





**FLEXLOC**

**ONE-PIECE SELF-LOCKING NUTS**

The FLEXLOC is one-piece, all-metal . . . has ample tensile and long life. It is a Stop and Lock-Nut that can be reused many times. Its "chuck-like", resilient locking segments lock the FLEXLOC securely in any position on a threaded member. It positively "won't shake loose", yet can be removed easily with a wrench.

See us at Space 128, A.S.T.E. Exposition, April 10-14, Convention Hall, Philadelphia

Write for Catalog 619, it's full of information.

**STANDARD PRESSED STEEL CO.**  
JENKINTOWN 10, PA.

**WHITNEY METAL TOOL COMPANY**  
41 YEARS EXPERIENCE



**WHITNEY-JENSEN Nos. 16-17-18 BENCH PUNCHES**

Roller-bearing, lever-type punches specifically designed for bench use. The powerful No. 18 has a higher and deeper throat than Nos 16 and 17; is an ideal tool for punching holes close to the web of an angle. Removable and adjustable die slices of the No. 18 permit use of close-fitting punches and dies. Work tables are available for all models.

	No. 16	No. 17	No. 18
Capacity —	3/8"	1/4"	1 1/2"
Mild Steel	thru	thru	thru
Throat Depth	3 1/2"	5 1/2"	7"
Throat Height	3/8"	1 1/8"	5"
Irregular Shaped Punches and Die: Available			

**WHITNEY METAL TOOL CO.**  
130 FORBES ST., ROCKFORD, ILL.

Premiere!

ALTEC presents the A-332A Amplifier, the first amplifier designed specifically for use with the famous ALTEC 21B Miniature Microphone! Internal power supplies eliminate the need for additional associated equipment, making it one of the finest compact, flexible public address amplifiers ever produced. It will accommodate any of the basic 21B Microphone types (stand, lapel or chest plate). Two mike channels . . . plus one for variable reluctance pickup . . . are provided with individual gain and bass controls. Overall high-frequency droop control is also provided. Inputs may be mixed in any ratio.

The A-332A is truly the answer to high quality public address or sound reinforcement systems that will meet the most stringent requirements of schools, churches, clubs, places of entertainment.

Amplifier is housed in grey metal cabinet. Front panel is lighted and slanted for easy manipulation of controls.

Ask for ALTEC brochures showing the best components to complete your high quality system.



**A-332A 18 watt Portable P. A. Amplifier**

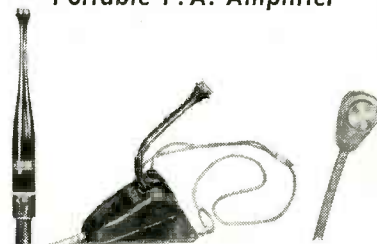

**DEALERS EVERYWHERE**

1161 N. VINE ST., HOLLYWOOD 38, CALIF.  
161 SIXTH AVE., NEW YORK 13, NEW YORK



Coil Worries?

**SEND FOR DR. DANO!**

Don't risk production weakness because you don't have the exact coil you need. Insist on Dano electrical coil windings—it's the perfect formula for healthy production. Dano makes every type of coil—and each is made to your exact specifications.

Also, TRANSFORMERS MADE TO ORDER

- Form Wound
- Paper Section
- Acetate Bobbin
- Molded Coils
- Bakelite Bobbin
- Cotton Interweave
- Coils for High Temperature Applications



**Following the Quality Curve Since 1923**  
AMPLIFIERS • TRANSFORMERS  
for  
BROADCAST • RECORDING • SOUND SYSTEMS  
Langevin Manufacturing Corporation  
37 West 65th St., New York 23, N. Y.

# Crystals for the Critical

## EVERYTHING YOU WANT IN "STABILIZED" CRYSTALS

High quality—quick delivery—modest cost! All three are yours when you use James Knights Co. "Stabilized" crystals.

Whether you wish standard crystals, or crystals built to your exact specifications, The James Knights Co. is equipped to supply you promptly.

A special production system is maintained to effect greater savings for you on short run jobs.

The James Knights Co. fabricates a complete line of "Stabilized" crystals to meet every need—precision made by the most modern methods and equipment.

Whenever you think of crystals, think of JK "Stabilized" crystals. They're your best bet—your best buy!

...

New James Knights Co. Catalog On Request



A tube research laboratory needed a 19 kc crystal to use as a standard. The James Knights Company delivered one in a hurry. A partially assembled H18T hermetically sealed unit on 19 kc is shown at the left. The James Knights Company does many kinds of special work for exacting customers every day.

The JAMES KNIGHTS Co.

SANDWICH, ILLINOIS



NEW PRODUCTS

(continued)

phlet on the design, application and servicing of selenium rectifiers. Besides including a complete description and tabulation of test and repair procedures, it supplies authoritative information on trouble-shooting methods for the half-wave circuit.

**Color Matching Instrument.** Instrument Development Laboratories, Inc., 541 Willis Ave., Williston Park, New York. A four-page folder covers the Color-Eye, a new industrial color measuring and comparison instrument. Inaccuracies due to stray light, variations in photo-cell characteristics, or illumination level variations, have been effectively eliminated by the basic design of the measuring instrument described.

**High-Frequency Tweeter.** Mark Simpson Mfg. Co., Inc., 32-28 49th St., Long Island City, N. Y. Catalog HF950 gives an illustrated description of the HFT-100 high-frequency tweeter. The unit described eliminates distortion, cumbersome horns and the need for crossover networks.

**Television Transmitter.** Federal Telecommunication Laboratories, Inc., 500 Washington Ave., Nutley 10, N. J., has available a bulletin dealing with the FTL-17A five-kilowatt air-cooled television transmitter. General description, design features and technical characteristics are included.

**Hum Eliminators.** Kalbfell Laboratories, Inc., 1076 Morena Blvd., San Diego 10, Calif. Model 503A Bridged-T filters which attenuate hum at least 50 db are adequately described in a single-sheet catalog. Included are graphs showing typical attenuation and impedance curves. A price list is also given.

**Production Test Equipment.** Tel-Instrument Co., Inc., 50 Paterson Ave., East Rutherford, N. J. A single-sheet bulletin presents a complete line of production test equipment for tv manufacturers. Eight units for advanced techniques are described and illustrated.

Where the  
Requirements  
are Extreme...

Use  
**SILVER  
GRAPHALLOY\***

For extraordinary  
electrical performance



THE SUPREME BRUSH  
AND CONTACT MATERIAL

### IN BRUSHES

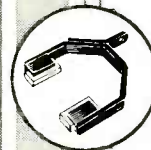

- for high current density

- minimum wear



- low contact drop

- low electrical noise

- self-lubrication

### IN CONTACTS



- for low resistance

- non-welding character



- SILVER GRAPHALLOY is a special silver-impregnated graphite

Accumulated design experience counts — call on us!

**GRAPHITE METALLIZING  
CORPORATION**

1055 NEPPERHAN AVENUE, YONKERS 3, NEW YORK



# The New STAVER MINI-SPRING

TRADE MARK REG. AND PAT. PEND.

A quality  
Tube  
Guard  
that is  
Bargain  
Priced



Gives support two ways—Keeps pressure downward and gives sideway support. The spring action is constant and resilient permanently. Send for catalog sheet.



Improved!!  
Recording!!

SPECIAL DESIGN  
EAD  
MOTORS

## DUAL and SINGLE SPEED HYSTERESIS

(Synchronous)  
MOTORS



TYPE	HORSE-POWER	RPM	SIZE
LH712NQCJ	1/100	900	
	1/50	1800	3 7/8" Dia. x 4-15/16"
LH712MNCJ	1/50	1800	
	1/40	3600	3 7/8" Dia. x 4-15/16"
LH731NCJ	1/50	1800	3 7/8" Dia. x 4-9/16"
LH730CJ	1/100	1800	3 7/8" Dia. x 4-1/16"
93H5K-1	1/20	1800	4 7/8" Dia. x 6-1/4"

- No Noise
- No Vibration
- Constant Speed
- Maximum HP
- Minimum Size
- Hunt and Wow Eliminated
- Independent of Load Inertia

- Long Life
- Dependability

The above motors are now standard with many of the country's leading manufacturers of disc, wire and tape recorders.

We are also currently producing a complete line of torque motors (re-wind and reel applications) for general use in recording equipment.

**EASTERN AIR DEVICES, INC.** 585 DEAN STREET  
BROOKLYN 17, N. Y.

## Lavite STEATITE CERAMIC



Design engineers and manufacturers in the radio, electrical and electronic fields are finding in LAVITE the precise qualities called for in their specifications... high compressive and dielectric strength, low moisture absorption and resistance to rot, fumes, acids, and high heat. The exceedingly low loss-factor of LAVITE plus its excellent workability makes it ideal for all high frequency applications.

Complete details on request

**D. M. STEWARD MFG. COMPANY**

Main Office & Works: Chattanooga, Tenn.  
Needham, Mass. • Chicago • Los Angeles  
New York • Philadelphia



## TOROIDAL INDUCTORS

High "Q" coils wound either to standard sizes or to your exact design specifications on the new Molybdenum Permalloy core. Our quality is unsurpassed, our prices welcome comparison. Use our new standoffs designed for simple coil mounting.

Write TODAY FOR Free  
PRICE LIST AND DATA SHEET

← Sample Inductors and Mounts

**TOROCOIL COMPANY** 5387 Northland Ave. St. Louis 12, Mo.

**Kay-Lab**  
LOGATEN

## LOGARITHMIC ATTENUATOR

THERMOSTATICALLY CONTROLLED  
50 DB RANGE



ACCURATE

STABLE

Output voltage is the logarithm of input voltage

Write for Bulletin 511a

**KALBFELL LABORATORIES, INC.**  
1076 Morena Boulevard  
San Diego 10, California

*Announcing*

**LINE-O-LIFE\***

*Brushes*

**EXCLUSIVE NEW FEATURE**

of **Carter**

**ROTARY POWER SUPPLIES**

At last Carter answers the age old question "WHEN SHOULD BRUSHES BE REPLACED?" And now ALL Carter products are equipped with this exclusive safety feature developed in the Carter laboratories. LINE-O-LIFE is a visual indicator mark, now on every new Carter brush. LINE-O-LIFE gives a positive, on-sight check for brush life expectancy . . . shows WHEN replacement is needed to assure full performance, and to avoid sparking and damage to commutator. Takes guesswork out of brush renewals. Easily the most significant improvement in brush construction in many years.

The exclusive Carter LINE-O-LIFE feature is fully explained in NEW circulars illustrating (1) the entire line of Carter Converters and (2) Carter Genemotors. These new circulars are now available on request, together with Converter Catalog No. 349. Write today, on your letterhead.

*Write Today*  
for Illustrated Circular  
and Catalog

**Carter Motor Co.**

2646 N. Maplewood Avenue

Chicago 47, Illinois

**NEWS OF THE INDUSTRY**

(continued from page 130)

facilities by governmental and non-governmental agencies. It will also make and present to the President evaluations and recommendations in the national interest concerning (a) policies for the most effective use of radio frequencies by governmental and non-governmental users and alternative administrative arrangements in the government for the sound effectuation of such policies, (b) policies with respect to international radio and wire communications, (c) the relationship of government communications to non-government communications, and (d) such related policy matters as the Board may determine.

**Radiological Instructor Courses**

THREE five-week instructor training courses in radiological monitoring techniques were recently announced by the Atomic Energy Commission. The announcement was made in cooperation with the National Security Resources Board, responsible for civil defense planning, and the General Services Administration, responsible for planning in the field of wartime disaster relief. Courses are open to qualified educators and technicians selected by State governors.

Two of the courses began March 13 at Brookhaven National Laboratory, Upton, Long Island, N. Y., and the Atomic Energy Project, U. of California, Los Angeles, Calif. The third will begin April 3 at Oak Ridge, Tenn. The latter course will be administered jointly by the Oak Ridge Institute of Nuclear Studies and the Oak Ridge National Laboratory.

Basic purpose of the courses is to provide technical information to selected individuals who could instruct local science teachers in monitoring techniques. The local science teachers could then be used to teach monitoring teams as part of state and municipal civil defense activity.

**New Atomic Element**

DISCOVERY of a new element, the heaviest known in the atomic scale, was recently announced by scient-

**MEASUREMENTS CORPORATION MODEL 80  
STANDARD SIGNAL GENERATOR**



**2 to 400 MEGACYCLES**

**MODULATION:** Amplitude modulation is continuously variable from 0 to 30%, indicated by a meter on the panel. An internal 400 or 1000 cycle audio oscillator is provided. Modulation may also be applied from an external source. Pulse modulation may be applied to the oscillator from an external source through a special connector. Pulses of 1 microsecond can be obtained at higher carrier frequencies.

**FREQUENCY ACCURACY**  $\pm .5\%$

**OUTPUT VOLTAGE**  
0.1 to 100,000  
microvolts

**OUTPUT IMPEDANCE**  
50 ohms.

- MANUFACTURERS OF**
- Standard Signal Generators
  - Pulse Generators
  - FM Signal Generators
  - Square Wave Generators
  - Vacuum Tube Voltmeters
  - UHF Radio Noise & Field Strength Meters
  - Capacity Bridges
  - Megohm Meters
  - Phase Sequence Indicators
  - Television and FM Test Equipment

**MEASUREMENTS CORPORATION**

BOONTON  NEW JERSEY



# ACE Ready-Built "Unit Cell" SCREEN ROOMS

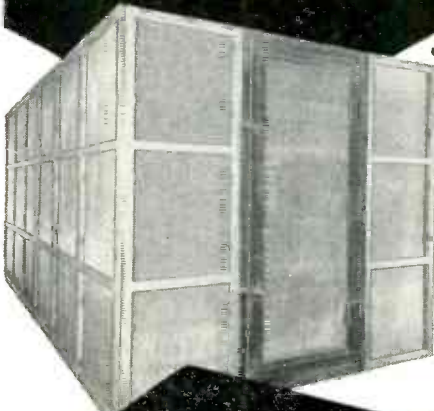

**MINIMUM  
of 100 DB.  
from 0.15 to 1000 mc.**

## Say Goodbye To Home Made Screen Rooms!

Expensive test equipment is a waste of good money if you restrict its measuring accuracy by inefficient, home-made shielded enclosures.

Ace Screen Rooms guarantee maximum attenuation—are supplied in ready built form for installation in a few hours, and actually cost less, all factors considered. Equally important, they can readily be enlarged or moved to a new location. Approved and used by leading laboratories and plants. Write, wire or phone for details.

**ACE ENGINEERING  
AND MACHINE CO.**   
3642 N. Lawrence Street  
PHILADELPHIA 40, PA. REgent 9-1019

ists of the radiation laboratory of the U. of California. Known as element 97, it is tentatively called berkelium, having the chemical symbol Bk, in honor of the city of Berkeley where the discovery was made by use of a 60-inch cyclotron.

This has been the culmination of four years of work, sponsored by the Atomic Energy Commission, in which the necessary background information of both the chemical and nuclear properties of the heavy elements has been investigated and systematized using both the 60-inch and the 184-inch cyclotrons at the U. of Calif.

### BUSINESS NEWS

KUPFRIAN MFG. Co., Binghamton, N. Y., is a new firm established for the manufacture of flexible-shaft couplings and wire shielding particularly for the electronics and instrumentation fields.

VULCAN ELECTRIC Co., manufacturers of electric soldering tools, has purchased the business of Jackson Electro Corp., New York City, and transferred the latter's manufacturing operations to Danvers, Mass.

AMERICAN TRANSFORMER Co., manufacturer of transformers and allied products, recently completed



American Transformer Company's new building

consolidation of all its operations into one building at 285 Emmet St., Newark, N. J.

EMERSON RADIO & PHONOGRAPH CORP. has purchased the Continental Can Building in Jersey City, N. J., to provide about 450,000 additional sq ft of space to set up production lines for tv and radio receivers.

WESTERN ELECTRIC Co. recently withdrew from the manufacture of broadcast equipment. Service to the industry in this field will now be made available by a new company,

## THE NEWEST SMALLEST SWITCHES

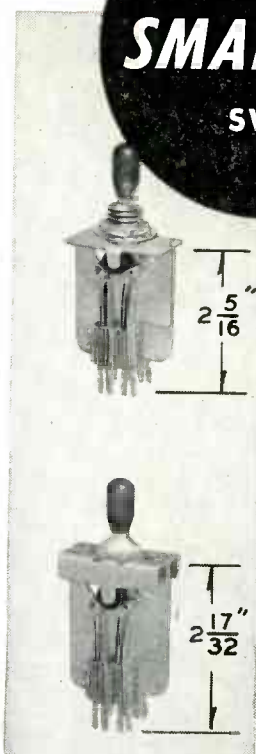

FOR  
ONE-HOLE  
MOUNTING

FOR  
STANDARD  
MOUNTING  
CENTERS

The new Type MCT-1 telephone-type switch — the smallest made — mounts in a single round hole — eliminates need for slotting panel and drilling and tapping four small holes — provides versatile switching action in addition to its standard features.

"Universal" Type MCT-4 Mounting plate has two sets of four, tapped, mounting holes to fit all standard mounting centers.

#### BOTH MODELS FEATURE

**Electrostatic shielding** between two sets of contact sections reduces coupling between circuits; frame hole provides for bonding shields in ganged assemblies.

**Versatile lever action** provides either locking on both sides, non-lock on both sides, non-lock on one side, lock on one side.

**Contact buildups** permit all popular as well as special circuit arrangements.

**Cam-spring mechanism** is especially designed for quiet operation and to reduce contact bounce to a new minimum.

**MCT Ratings**  
Palladium contacts rated at 1 amp. at 115 volts, 60 cycles, non-inductive load.  
Request Catalog Sheet and B/P #D35-100 giving details of contact arrangements, dimensions, and prices.

  
**GENERAL  
CONTROL  
COMPANY**  
1202 SOLDIERS FIELD ROAD  
BOSTON 34, MASSACHUSETTS

FOR DEMONSTRATING & TESTING AUTO RADIOS from AC LINES



**ATR**

**"A" BATTERY ELIMINATORS**



**for DEMONSTRATING AND TESTING AUTO RADIOS**

New Models . . . Designed for testing D. C. Electrical Apparatus on Regular A. C. Lines. Equipped with Full-Wave Dry Disc Type Rectifier, Assuring Noiseless, Interference-Free Operation and Extreme Long Life and Reliability.



**AUTO RADIO VIBRATORS**

A Complete Line of Vibrators . . . Designed for Use in Standard Vibrator-Operated Auto Radio Receivers. Built with Precision Construction, featuring Ceramic Stack Spacers for Longer Lasting Life.

NEW MODELS ✓ NEW DESIGNS ✓  
NEW LITERATURE ✓  
ATR "A" Battery Eliminator, DC-AC Inverters, Auto Radio Vibrators  
See your jobber or write factory

**AMERICAN TELEVISION & RADIO Co.**  
Quality Products Since 1931  
SAINT PAUL 1, MINNESOTA-U.S.A.

the Standard Electronics Corp., Providence, R. I., with distribution through Graybar.

THE BRUSH DEVELOPMENT Co., Cleveland, Ohio, manufacturers of piezoelectric devices, sound recorders and prevision instruments, recently formed its new Hypersonic Division for experimentation and industrial application of ultrasonic energy.

**PERSONNEL**

MERLE M. ANDREW, formerly engaged in operational research with the Naval Operations Evaluation Group, has joined the staff of the machine development section of the National Bureau of Standards' applied mathematics laboratories, where he will supervise the preparation of mathematical problems to be solved by the Bureau's electronic computers.

PHILIP J. FREED has been promoted from project engineer to business manager of Haller, Raymond and Brown, Inc., State College, Pa., an electronic research and engineering organization.

TITUS G. LECLAIR, assistant chief electrical engineer at Commonwealth Edison Co., Chicago, Ill., was recently elected president of the AIEE for the term beginning Aug. 1, 1950.

CLARE C. FISHER, formerly associated with Magnavox Co., is now chief engineer with Utah, Inc., Huntington, Ind.



C. C. Fisher



R. L. Grove

R. L. GROVE, previously with the Centralab Division of Globe Union, Inc., Milwaukee, Wisc., has been appointed chief engineer of Cornell-Dubilier's Ceramic Division in New Bedford, Mass.



TWO NEW COIL FORMS by CAMBRIDGE THERMIONIC

These two new slug tuned coil forms by Cambridge Thermionic Corporation are designed to give you top performance while fitting easily into small or hard-to-reach places. Illustrations are actual size.

Both have silicone impregnated ceramic bodies, grade L-5, JAN-I-10 for high resistance to moisture and fungi. Ring terminals are adjustable. Both sizes are provided with a spring lock for the slug, and the mounting stud is cadmium plated to withstand severe service conditions.

The LS-5 and LS-6 are available with high, medium or low frequency slugs. Mounting hardware is supplied.

Ask for CTC's new Catalog #300 describing our complete line of *Guaranteed Components*.

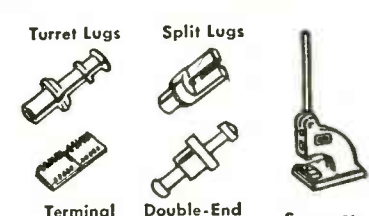

**Custom or Standard The Guaranteed Components**  
CAMBRIDGE THERMIONIC CORP.  
437 Concord Ave., Cambridge 38, Mass.



**New!** DIRECT-COUPLED  
Thyratron Controlled  
STABILIZED and REGULATED  
Adjustable D. C. Power Supplies



Designed for universal industrial and laboratory use where high speed (0.05 sec.) load regulated and line stabilized heavy duty adjustable direct current power supplies are required. All models employ a new type of direct-coupled stepless control voltage correction amplifier which provides a constant DC output (within  $\pm 0.1\%$ ) under conditions of simultaneous variation of power line from 90 to 130 volts and load from no-load to full rated output.

Models available for output currents up to 10 amperes (filtered to less than 1%) and output voltages up to 500 volts.

Write for complete technical literature and prices on 10 different models.

Industrial Division

**AMPLIFIER CORP. OF AMERICA**

398-7 Broadway, New York 13, N. Y.

NOTICE TO MANUFACTURERS  
AND SUPPLIERS OF  
ELECTRONIC COMPONENT  
PARTS AND  
ASSOCIATED MATERIALS

Attention is invited to the qualification approval stipulation appearing in most Military (JAN) specifications coming under the purview of the Armed Services Electro Standards Agency. This in substance is as follows:—In the procurement of products requiring qualifications, the right is reserved to reject bids on products that have not been subjected to the required tests and found satisfactory for inclusion on the Army-Navy-Air Force Qualified Products List. The attention of suppliers is called to this requirement, and manufacturers are urged to communicate with the Armed Services Electro Standards Agency (ASESA), Fort Monmouth, N. J., and arrange to have the products that they propose to offer to the Army, the Navy, or the Air Force, tested for qualification in order that they may be eligible to be awarded contracts or orders for the products covered by these specifications. Information pertaining to qualification of products covered by these specifications and a complete index of the specifications may be obtained from the Armed Services Electro Standards Agency (ASESA), Fort Monmouth, N. J.

*Introducing the Berkeley*

**EPUT\***  
METER

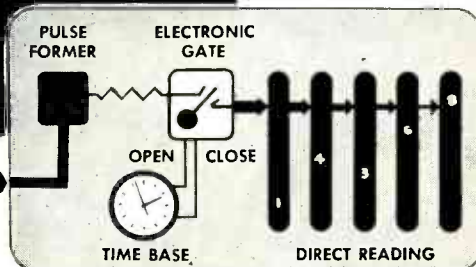

Any physical, optical or electrical events which can be translated into changing voltages can be counted for a specific time interval by this new Berkeley \*Events-per-Unit-Time-Meter.

Signals of unknown occurrence rate are amplified, properly shaped by the input circuit and admitted through the time base controlled electronic gate to the Decimal Counting Units. The instrument then reads directly in Events-Per-Unit Time.

Send for bulletin for full, detailed description.

*Berkeley Scientific Company*

SIXTH AND NEVIN AVENUE • RICHMOND, CALIF.



The answer to many of your UHF insulating, sealing, terminating problems. Write for free literature and samples.

**SELF BONDING TAPE**

for Insulating and Hermetic Sealing

Radio • Television • UHF Components • Installations

- Excellent HF Dielectric—S.I.C. 2.13 and P.F. 0.004 @ 10 mc. Breakdown over 1000V/MIL.
- Fuses to a solid mass—positive, permanent moisture seal.
- Unaffected by moisture, corrosive fumes, ozone, sunlight, oxygen, or corona.
- Shapes to any contour.

Ideal for sealing HF pi inductances, HV lead-ins, and HF power supply parts. Provides arcover protection at high altitudes—used for coaxial or flat line splicing and sealing.

**BISHOP MANUFACTURING CORPORATION**

Established 1847

420 East 25th Street

New York 10, N. Y.



Model 99  
Unit shown  
above with-  
out cover

- AC stand-by switch—green
- High Voltage switch—red
- Variable voltage control knob
- All aluminum construction

- Focusing voltage control (optional)
- Size—17x13x9"
- Tubes 1—5U4, 1—6L6, 1—1625, 3—1B3's

Write for complete information

**INDUCTOGRAPH PRODUCTS**

Dept. A, 236 W. 55 St., N. Y. 19, N. Y.

**VARIABLE HIGH VOLTAGE  
RF POWER SUPPLY—1 to 40 KV**

POSITIVE OR NEGATIVE OUTPUT

Carefully designed and engineered to answer the needs of Industrial users and Research Engineers in the fields of electrostatic painting, nuclear and physics research, insulation testing, precipitators, projection television, etc.

# New diacro POWERSHEAR

OFFERS  
CONTINUOUS ACTION

*plus*

VARIABLE SPEED

from 30 to 200 strokes per minute



## for high speed DIE-LESS DUPLICATING

The new Di-Acro POWERSHEAR has remarkable speed and accuracy for the production of small parts.

1. CONTINUOUS SHEARING ACTION—no clutch to engage! Feeding speed determines shearing speed.
2. VARIABLE SPEED—cycle quickly set for each shearing operation.
3. EASE OF OPERATION—fatigue is reduced, production soars.
4. "SINGLE STROKE" SHEARING—non-repeating safety clutch for jobs not adaptable to continuous shearing.

Any plant doing high speed precision shearing on smaller parts cannot afford to be without the DI-ACRO POWERSHEAR. Available in 12" and 24" shearing widths, capacity 16 gauge sheet steel. Also standard model.

### DOES PRECISION WORK ON ALL SHEARABLE MATERIALS

MICA	SILVER	CHROME MOLY
PLASTICS	MAGNESIUM	LEADED BRASS
BIMETALS	COPPER	STAINLESS STEEL
FIBRE	ALUMINUM	and Many
LEATHER	SILICON STEEL	Other Materials

Pronounced  
"DIE-ACK-RO"

See Di-Acro Exhibit Booth 316  
Tool Engineers' Industrial Exposition  
Philadelphia, Pa., April 10-14.



Send For 40-Page  
"DIE-LESS" DUPLICATING  
Catalog



O'NEIL-IRWIN MFG. CO.

321 8th Avenue, LAKE CITY, MINN.

V.L.F.!!  
Very Low Frequencies!



CONFORMS TO ALL  
REQUIREMENTS OF  
C63.2 RADIO NOISE  
METER SPECIFICATION  
ADOPTED BY AMERICAN  
STANDARDS ASSOC-  
IATION, OCTOBER 26,  
1949

## STODDART NM-10A RADIO INTERFERENCE AND FIELD INTENSITY METER

- MEASURES radiated and conducted signals.
- RANGE—14 kc to 250 kc.
- SENSITIVITY—Field strength using rod antennas one microvolt-per-meter to 2 volts-per-meter. Field strength using shielded loop antennas 10 microvolts-per-meter to 100 volts-per-meter.
- READS directly in microvolts and db.
- A.C. POWER SUPPLY 105 to 125 volts or 210 to 250 volts, 50 CPS AND 1600 CPS. No shock hazard.

Write for complete technical data

STODDART AIRCRAFT RADIO CO.

Main office and plant:  
6644 SANTA MONICA BLVD., HOLLYWOOD 38, CALIF., Phone: Hillside 9294

implies, it deals with the measurement of the important quantity, time, both in an absolute sense (total time elapsed between two events) and in a relative sense (the difference between two elapsed times of almost equal—but not predetermined—values.) In the latter case, the term electronic in the title is a bit misleading, as the only means considered is that of the ultrasonic delay line.

The good as well as the bad features of Volume 19 are retained in Volume 20, which is really a companion book to the preceding work. Every circuit discussed is shown in schematic form, with most containing component values and special component type numbers. If anything, this volume leans a little more heavily on descriptions of the methods of operation of existing equipments. The typography is excellent and the style amazingly consistent considering the large number of contributors. (It is interesting to note that practically every reviewer of a Radiation Laboratory Series volume has included the above comments on style).

As before, however, this reviewer feels that the terminology employed is unnecessarily elegant and is not that which is familiar to the engineer. The value of the book would be enhanced if an effort had been made to adapt the technical language to that of the ultimate user, the engineer.

Although some mention is made of phase and frequency-modulation methods of measuring time, the major part of the work is devoted to methods employing pulse techniques. Methods of pulse-time measurements and the generation of both fixed and movable indices are discussed. Measurements of time by both manual and automatic means are described, with special emphasis on some of the well-known systems which were products of wartime requirements for accurate bombing and gun laying. The last portion of the book deals with the special problems of data transmission (essentially the reproduction of the time intervals between a series of events) and the measurement of relative time intervals by delay and cancellation methods.

This reviewer finds himself in



the peculiar position of heartily recommending this volume for the tremendous amount of valuable information it presents, and at the same time criticizing the language which was used in its presentation. —MATTHEW T. LEBENBAUM, Receiver Section, Airborne Instruments Laboratory, Mineola, N. Y.

### Saturating Core Devices

BY LEONARD R. CROW. *The Scientific Book Publishing Co., Vincennes, Indiana*, 1949, 373 pages, \$4.95.

A RATHER COMPLETE work giving explanations and numerous illustrations showing most of the basic saturating core devices. It describes, theoretically, several basic modes of operation and shows their applications to practical devices such as relays, controllers, regulators, amplifiers, field measuring devices and servomechanisms.

The book is written for the student who may not be well founded in mathematics or in alternating current theory. As in most other works, the explanations are mainly based on the steady-state a-c characteristics of saturating core devices.

This reviewer feels that more space should have been devoted to giving the reader a physical understanding of the reactor as an instantaneously nonlinear device.

The book contains a good list of references and is recommended for the novice as well as a refresher for the experienced electrical engineer. —F. H. SHEPARD, JR., Consulting Engineer, Summit, N. J.

### Books Received for Review

**CLINICAL ELECTROENCEPHALOGRAPHY.** By Robert Cohn, Director of Neurological Research, U. S. Naval Hospital, Bethesda, Md. McGraw-Hill Book Co., New York, 1949, 639 pages, \$14.00. Interpretation of human electroencephalograms as obtained with a six-channel electroencephalograph fed by electrodes positioned to pick up brain potential variations. The 273 EEG tracings shown, each with case histories, statistical data and diagnostic data on facing pages, are appropriately chosen from studies of approximately 10,000 patients. Technical introduction analyzes wave phenomena encountered and gives performance requirements of amplifying and recording equipment required.

**THE RADIO AMATEUR'S HANDBOOK.** American Radio Relay League, West Hartford, Conn., 27th edition (1950), 736 pages including catalog section, \$2.00. Revised and restyled, with increased emphasis on high-frequency equipment.

## More Contacts . . . In Less Space!

### GRAYHILL Series 5000 MINIATURE MULTI-DECK SWITCH

#### Two Types:

**Shorting**—(Make before break)

**Non-Shorting**—(Break before make)

#### Rated:

To break 1 amp. at 115 volts AC—carries 5 amp.

The most versatile miniature switch out. It will accommodate from 1 to 10 positions. Available for complete 360° clockwise or counter-clockwise operation. When less than 10 positions are used, stops may be provided so as to permit rotation only through given number of contacts. Additional decks up to 10 may be added, permitting up to 100 contacts in only 4-15/32".

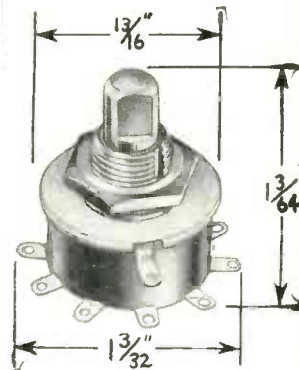

Ask for further information without obligation.

*Grayhill*

4522 WEST MADISON STREET  
CHICAGO 24, ILLINOIS



### Features

- Low Loss
- High KVA Rating
- Shielded From External Electrostatic Fields
- Low Internal Distributed Inductance
- Complete Dependability

## Dependable! JOHNSON PRESSURIZED CAPACITORS

Use of a gas dielectric under pressure permits high voltage ratings and large values of capacity in a small volume of space, yet all the advantages of air dielectric capacitors are retained. Construction prevents erratic performance due to changes of barometric pressure or humidity as well as excluding all foreign matter which could cause flashovers. In contrast to comparable solid dielectric capacitors, permanent damage to JOHNSON pressurized capacitors from flashovers is improbable.

JOHNSON designed and built pressurized capacitors are available in fixed, variable and semi-variable types. Capacity values to 10,000 mmf., voltage ratings to 32,000 volts peak and currents from 40 to 80 amperes are available in standard units. Special units with even higher voltage and current ratings can be supplied.

Plates are polished aluminum with rounded edges. Shells are copper plated steel; insulation steatite. Seals are corprene which is impervious to moisture and oil, is stable and does not deteriorate with age. Dielectric is 200 P.S.I. oil pumped nitrogen.

The reliable performance of JOHNSON pressurized capacitors is due to conservative design and excellent workmanship. Complete dependability is assured.

Write For  
Illustrated JOHNSON Catalog and Prices



**JOHNSON** . . . a famous name in Radio  
E. F. JOHNSON CO. WASECA, MINNESOTA

# Engraving

## PROFILING VERTICAL MILLING

**Here is the most versatile machine... So simple to operate by unskilled labor.**

**NEW HERMES**  
*Engrave*

**This heavy duty bench type model covers a larger engraving area than any other machine of its kind.**

Send for illustrated booklet H

**NEW HERMES, Inc.**

Dept. 29  
13-19 UNIVERSITY PL. • NEW YORK 3  
World's Largest Manufacturer  
of Portable Engraving Machines

### BACKTALK

(continued)

light was actually a cluster of five hairpin filament lamps operated in series on the 500-volt trolley circuit.

Further experimenting at home with a similar lamp bulb disclosed that on 60 cycles a low-pitched tone resulted. I was curious to see whether a continuous wave was emitted under d-c excitation and accordingly connected up a motor generator. I was not able to filter the commutator ripple well enough to produce a steady carrier; however, it was obvious that the trolley signal was likewise tone modulated by the various commutator ripples on the line. A further experiment was run using r-f from a ham transmitter to light the filament. Modulation of the exciter transmitter in turn produced modulated vhf lamp output.

It was noticed that electrically charged areas were formed on opposite sides of the glass envelope. A piece of brass sheet or the hand held near these places broadened the frequency band being emitted. A magnet held near the lamp lengthened the wavelength.

It was discovered that the filament length (temperature) affected the frequency. This came about when the above magnet experiment nearly destroyed one filament. The magnetic field caused the filament to vibrate mechanically so strongly that a portion of one hairpin was shorted out and welded together. The next step was to vary the filament voltage while observing the wavelength.

As a result of my experiments I reached the conclusion that a form of Barkhausen oscillation or "electron dance" was the cause of the radiation. The electrons emitted on one side of the lamp were subjected to the potential across the lamp (some 160 volts peak) whereupon the more positive filament portion became an anode. The smallness of the target of course produced many "misses" with resulting Barkhausen oscillation. The charges on the glass (or darkened metallized areas thereof) were possibly due to some of the spent electrons although they may have aided in the mechanism of buildup.

Several years later I was able to construct a vacuum tube to prove

## The BROOK High Quality AUDIO AMPLIFIER

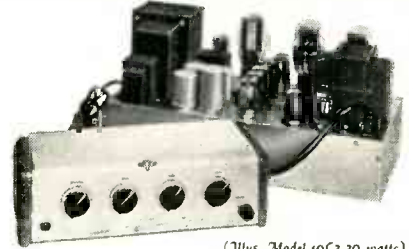

(Plus, Model 10C3-30 watts)  
Also available: Model 12A3-10 watts.

All Low Mu Triodes Plus Brook made Transformers Plus Brook's own Circuits	} = {	Finest Audio Quality you ever listened to Minus Listening Fatigue Plus High Quality at extremely low volume Plus High quality at the full loudness of a band or symphony
---	-------	--

"You can believe your ears when you listen with a Brook Audio Amplifier"

Write TODAY for FREE Technical Bulletin and Detailed Distortion Analysis

**BROOK ELECTRONICS, Inc.**  
Dept. BD-0, 34 DeHart Place • Elizabeth, N. J.

### FOR RECORDING

## TELEMETERING SIGNALS (up to 40 kc.)



Almost overnight Ampex Magnetic Tape Recorders revolutionized radio network broadcasting. Ampex succeeded in this most critical service because of simple and dependable operation, plus a tone quality that is unequalled. Ampex is now available in several models for a wide range of requirements. Inquiries for special instrumentation and industrial control application promptly answered.

- MODEL 300-C \$1575
- VU METER PANEL (EXTRA) \$105 (F.O.B. San Carlos)

IMPORTANT NEW TOOL FOR INDUSTRY AND SCIENCE

# AMPEX

## MAGNETIC TAPE RECORDER

"STANDARD OF THE GREAT RADIO SHOWS"

Get FREE BOOKLET today!

AMPEX ELECTRIC CORP., San Carlos, California  
Without obligation please send 16-page illustrated booklet containing technical specifications of Ampex Magnetic Tape Recorders.

NAME \_\_\_\_\_

ADDRESS \_\_\_\_\_

CITY \_\_\_\_\_ STATE \_\_\_\_\_

- Our need is for:
- |  |  |
|--|--|
| <input type="checkbox"/> Laboratory Research     | <input type="checkbox"/> Telemetry             |
| <input type="checkbox"/> Multi-Channel Recording | <input type="checkbox"/> Industrial Recording  |
| <input type="checkbox"/> Recording-Broadcasting  | <input type="checkbox"/> Aerophysical Research |
|  | <input type="checkbox"/> Private Home Use      |

Distributed by . . .

BING CROSBY ENTERPRISES (Hollywood)  
AUDIO & VIDEO PRODUCTS CORP. (New York City)  
GRAYBAR ELECTRIC COMPANY (Everywhere)  
EXPORT: WESTREX (New York City)

For Proof Beyond Compare



Try

## RUBYFLUID Soldering Flux

Send for Ruby's \$1 Offer

For \$1 Ruby will send you 1 pint of liquid, one half pound of paste soldering flux and a new booklet on "How to Solder."

Take advantage of this offer now!

Send your \$1 today to—

**RUBY CHEMICAL CO.**



59 McDOWELL ST.  
COLUMBUS, OHIO

**Rubyfluid**



# PROFESSIONAL SERVICES

Consulting—Patents—Design—Development—Measurement

in

Radio, Audio, Industrial Electronic Appliances

**AMPLIFIER CORP. of AMERICA**  
*Research, Design, Development  
and Manufacturing Engineers*  
Specializing since 1936 in All Phases of  
MAGNETIC TAPE RECORDING FOR  
ALL APPLICATIONS

Precision Regulated Power Supplies  
A. C. Shaney, Chief Engineer  
398-7 Broadway New York 13, N. Y.

**WHEN TIME IS SHORT . . . . .**  
put the solution of your problems up to  
a specialized Consultant whose profes-  
sional card appears on this page. His  
broad experience may save you months  
of costly experimentation.

**ELECTRONICS**  
330 West 42nd St., New York 18, N. Y.

**PICKARD AND BURNS, INC.**  
*Consulting Electronic Engineers*

Analysis and Evaluation  
of Radio Systems  
Research, Development & Design  
of Special Electronic Equipment  
240 Highland Ave., Needham 94, Mass.

**CROSBY LABORATORIES**

*Murray G. Crosby & Staff*

FM, Communications, TV,  
Industrial Electronics,  
High-Frequency Heating  
Offices, Laboratory & Model Shop at:  
126 Herricks Rd., Mineola, N. Y.  
Garden City 7-0284

**HANSON-GORRILL-BRIAN INC.**

*Product & Mfg. Development*

ELECTRICAL - ELECTRONIC  
HYDRAULIC - MECHANICAL  
One Continental Hill Glen Cove, N. Y.  
Glen Cove 4-1922

**ALBERT PREISMAN**

*Consulting Engineer*

Television, Pulse Techniques, Video  
Amplifiers, Phasing Networks,  
Industrial Appliances  
Affiliated with  
MANAGEMENT-TRAINING ASSOCIATES  
3308-14th St., N.W. Washington 10, D. C.

**EDGERTON, GERMESHAUSEN  
& GRIER, INC.**

*Consulting Engineers*

Research, Development and Manufacture  
of Electronic and Stroboscopic Equipment  
Specialists in High-Speed Photography  
160 Brookline Avenue, Boston 15, Mass.

**KENT LABORATORIES, INC.**

*Model Work in Metal & Plastics*

Electro - Mechanical  
Design - Development - Manufacture  
Precision Mechanical Specialists  
230 Warburton Ave. Hawthorne, N. J.  
Telephone HA wthorne 7-6777

**SERVO  
CORPORATION OF AMERICA**

*Consultants on*

Electronic Control Problems  
for Industry  
New Hyde Park Long Island, N. Y.

**ELECTRO-MECHANICAL RESEARCH INC.**  
*Specialized Research and Manufacture*

High and Low Frequency Circuit Development  
Electronic Measuring and Test Equipment  
Optical and Infra-Red Studies  
Special Geophysical Equipment  
Automatic Inspection Devices  
Ridgefield, Conn.

**MEASUREMENTS CORP.**

*Research & Manufacturing  
Engineers*

Specialists in the Design and  
Development of Electronic Test Instruments  
Boonton, N. J.

**SERVO-TEK PRODUCTS CO., INC.**

*Servo-Systems • Position Recorders  
Motor-Integrator Systems*

Specialists in Electronic Motor Speed Control  
4 Godwin Avenue Paterson, N. J.  
Tel. ARmory 4-3366 Teletype PAT 199

**ELECTRONIC ENGINEERING  
CO. of CALIFORNIA**

Radio and Electronic Consulting and  
Designing.

180 S. Alvarado Los Angeles  
DUnkirk 7-8323 California

**MICROCIRCUITS COMPANY**

*Consultation-Development-Manufacture*

PRINTED CIRCUIT  
APPLICATIONS and PAINTS  
Conducting, Resistance, and Magnetic  
Paints, Pastes, and Hot Melts  
for Experimentation and Production  
New Buffalo Michigan

**TECHNICAL  
MATERIEL CORPORATION**

*Communications Consultants*

RADIO TELETYPE • FREQUENCY SHIFT  
INK SLIP REORDING  
TELETYPE NETWORKS  
453 West 47th Street New York 19, N. Y.

**ERCO RADIO  
LABORATORIES, INC.**

*Radio Communications Equipment*

Engineering - Design - Development - Production  
Pioneers in Frequency Shift Telegraph  
Garden City • Long Island • New York

**Eugene Mittelman, E.E., Ph.D.**

*Consulting Engineer & Physicist*

High Frequency Heating — Industrial Electronics  
Applied Physics and Mathematics  
549 W. Washington Blvd. Chicago 6, Ill.  
State 2-8021

**ANDREW W. VINCENT**

CONSULTANT

*Development and Models*

Electromagnetic relays & devices Audio and In-  
tercommunication equip. Remote control selection  
circuits, Telephone equipment,  
300 W. High Terrace Rochester, N. Y.  
Genesee 2648

**PAUL GODLEY CO.**

*Consulting Radio Engineers*

GREAT NOTCH, N. J.

Est. 1926 Little Falls 4-1000

**NIAGARA ELECTRON LABORATORIES**

CONSULTATION - DESIGN - CONSTRUCTION  
MFG. THE THERMOCAP RELAY

Specializing in solution of problems of electronic  
and electro-physical instrumentation for the re-  
search or analytical laboratory. Industrial plant  
problems also invited.  
Andover, New York Cable Address: NIATRONLAB

**YARDENY LABORATORIES, INC.**

*Research and Development*

Remote Controls and Electro Chemical  
Generators of Energy

105 Chambers Street WO 2-3534, 35  
New York, N. Y.

**THE  
REAL  
VALUE**

*of placing your unusual problem in the hands of a competent con-  
sultant is that it eliminates the elements of chance and uncertainty  
from the problem and provides real facts upon which to base decisions.*

my theory. I supported two parallel filaments within a bulb and made one hot cathode and the other a cold or hot anode at will. The same oscillation at vhf was produced.

In the light of the foregoing I think you should revise your explanation of how the lamp produces a radiation. It seems perfectly clear to me that the oscillation will possess pulse character on 60 cycles a-c since the potential must be suited to the transit time before oscillation can start. Therefore only the peaks of the house current produce an oscillation.

Several diode oscillators are patented which come close to the subject; however, I believe that Bruce (Bell Telephone, 2,254,264), comes closer to making a practical thing out of it than anyone. The earliest reference I can find is British 258,989 dated October 1926. Fritz, 2,197,338 and Hollman 1,978,021 describe a similar device.

Possibly some day a citizens band transmitter will be made using specially made tubes working on this principle.

LEO J. HRUSKA  
Lutherville, Maryland

**L and k**

DEAR SIRs:

I WAS PLEASED to see the *Tubes at Work* article, "Simplified Measurement of L and k", by V. A. Sheridan, in the August, 1949 issue of **ELECTRONICS**. Sheridan's work corroborates my own conclusions that this is a very practical method of measuring the coefficient of coupling between two coils, and is far superior to the usually described methods.

The effect of coil Q on the measurement is also interesting. It is easy to show (see my article "Note on Measuring Coupling Coefficient", *Radio*, Feb. 1945), the primary coil Q<sub>1</sub> does not enter the equation.

In many instances, (if the secondary coil Q<sub>2</sub> ≥ 10) the test may be performed at 1,000 hertz with the coils *in situ* and without removing connecting wires.

PIERRE M. HONNELL  
Associate Professor  
Washington University  
St. Louis, Missouri

# CONTACTS

FOR THE FIELD OF ELECTRONICS



**FINE RIBBONS OF TUNGSTEN and Molybdenum**  
Quality and accuracy in our fabrication of Tungsten & Molybdenum Ribbons have characterized our service to the Electronic industry.  
A development of  
**H. CROSS CO.**  
15 Beekman St., New York 7, N.Y.

**CEMENTS FOR THE RADIO INDUSTRY**

NITROCELLULOSE SYNTHETIC  
MOISTURE RESISTANT  
THERMO PLASTIC  
THERMO SETTING  
VINYL IN COLOR  
COIL VARNISH

**BARRETT VARNISH CO.**  
1532 South 50th Court  
Cicero 50, Ill.

Write Us for Additional Information



**EISLER— Manufactures Complete Equipment for:**  
SPOT WELDERS, Electric, for 1/4 to 250 KVA.  
A.C. ARC WELDERS from 100 to 400 Amps.  
TRANSFORMERS, Special and Standard Types.  
INCANDESCENT LAMP Manufacturing Equipment.  
FLUORESCENT TUBE Manufacturing Equipment.  
NEON SIGN MAKERS EQUIPMENT.  
ELECTRONIC EQUIPMENT, Vacuum Pumps, etc.  
WET GLASS SLICING and Cutting machines for Laboratory use.  
EISLER ENGINEERING CO., INC., 774 So. 13th St., Newark 3, N. J.



**GRC WING NUTS** TOP QUALITY PRICED LOWER  
Rust-proof zinc alloy with GRC's recessed-wing finger-grip. All commercial finishes, all popular thread sizes. Special threads or untapped wing nuts; special designs to order.  
Write today for samples and prices—and compare! Immediate Deliveries.  
**GRIES REPRODUCER CORP.**  
100 Willow Ave., New York 54, N. Y.



**FLUXES**  
SODERING BRAZING & WELDING  
L. B. ALLEN CO. INC. Chicago 31, Ill.  
6751 Bryn Mawr Ave.

**SUB-MINIATURE PRINTED ELECTRONIC CIRCUITS**  
produced from your schematics or existing electronic equipment. Circuits fired on ceramics or air dried on plastics and paper bases. Confidential service.  
**PLASTICS & ELECTRONICS CO.**  
272 Northland Ave., Buffalo 8, New York

**EL-TRONICS, INC.**  
Research, development, and manufacture of electronic equipment—a single model to large quantities.  
Specialists in Geiger-Muller equipment  
2647-67 N. Howard St., Phila. 33, Pa.  
Garfield 5-2026

**PRINTED CELLOPHANE**  
Colorful - Self Adhesive - Cellophane, processed in Rolls. Easy to buy - Easy to apply - used for Packaging - Point of Sale advertising - Parts marking and Aircraft Wire terminal identification.  
**TOPFLIGHT TAPE - YORK, PA.**

**MICROMETER FREQUENCY METER** will monitor any number of frequencies, FM or AM, 100 KC to 175 MC  
**LAMPKIN LABORATORIES, INC.**  
Bradenton, Fla., U. S. A.

**POWER SUPPLY PROBLEM?**  
If you can't find the commercial power supply with range and capacity you need we'll design one and build it for you.  
**BUCK ENGINEERING CO.**  
37-39 Marcy St. Freehold, N. J.

**ATOMIC ENERGY NEWSLETTER**  
The business paper of the atomic energy industry For suppliers & contractors to the atomic energy program—and for those who want to participate—Atomic Energy Newsletters furnish up-to-the-minute, primary market data on the atomic energy industry.  
Use these specialized, bi-weekly Newsletters to keep abreast all nuclear energy work & development.  
\$18.00 a year, U. S. & Canada  
**ATOMIC ENERGY NEWS INC. 509 5th Ave NY 14**



**DC 4 COMPOUND**  
THE NON-MELTING SILICONE INSULATING AND WATERPROOFING COMPOUND FOR IGNITION SYSTEMS AND ELECTRONIC EQUIPMENT.  
MEETS ALL REQUIREMENTS OF AN-C-128a.  
STABLE AT TEMPERATURES FROM -70° to +400°F.  
For more data on DC 4 Silicone compound write Dept. J  
**Dow Corning**  
FIRST IN SILICONES  
**DOW CORNING CORPORATION**  
MIDLAND, MICHIGAN  
Atlanta • Chicago • Cleveland • Dallas  
Los Angeles • New York  
Canada: Fiberglas Canada, Ltd., Toronto  
Great Britain: Albright and Wilson, Ltd., London



**TERRITORY AVAILABLE**

We are manufacturers in the electronic measuring, communications, and control fields. We require several exceptional men in various sections of the country to handle our products in addition to their present lines. Better than average reward for those qualifying. Give full particulars in initial correspondence.

RW-2421, Electronics  
520 N. Michigan Ave., Chicago 11, Ill.

REPLIES (Box No.): Address to office nearest you  
NEW YORK: 330 W. 42nd St. (18)  
CHICAGO: 520 N. Michigan Ave. (11)  
SAN FRANCISCO: 68 Post St. (4)

**POSITION VACANT**

ASSISTANT TO Chief Engineer — large specialty transformer manufacturer wants man experienced in small transformer work—excellent opportunity for qualified man. Please state education and work experience also salary on last or present position. Southern Ohio location. All replies held strictly confidential. Suitable arrangements will be made to interview qualified applicants. P-2436, Electronics.

**EMPLOYMENT SERVICE**

SALARIED PERSONNEL \$3,000-\$25,000. This confidential service, established 1927, is geared to needs of high grade men who seek a change of connection under conditions assuring, if employed, full protection to present position. Send name and address only for details. Personal consultation invited. Jira Thayer Jennings, Dept. L, 241 Orange St., New Haven, Conn.

**POSITIONS WANTED**

ELECTRICAL ENGINEER, recent graduate, desires trainee position: research or development field with progressive company. Former R.T., single, 23. Will relocate. PW-2202, Electronics.

COMMUNICATIONS TECHNICIAN 14 yrs. exp. all phases. Design & Mfr. Comm. & Electronic eqpt. Patents. Travelled Europe & SA. 9 yrs. Brazil. PW-2220, Electronics.

ELECTRICAL ENGINEER: M.S. Physics, M.S. E.E., 10 years research, development, design experience magnetic and disc recording, acoustic design and measurements, magnetic recording systems for computer applications. Employed—desire change to smaller co. or consulting organization. PW-2361, Electronics.

EXECUTIVE ENGINEER, seeks new connection. Harvard graduate in communication engineering, Senior Member I.R.E., member American Institute of Physics, Associate Member A.E.E.E., Registered professional engineer. Diversified experience in invention, development, design, production and marketing of electronic and acoustical products on a national scale. Also university teaching experience a-c circuits, electronics, communication engineering. PW-2468, Electronics.

**SELLING OPPORTUNITY WANTED**

WANTED RADIO and T. V. Accounts for West Coast representation. Pioneer radio engineer with wide acquaintance, former naval officer, radiation lab. executive and consulting radio engineer seeks reliable worthy accounts. P. O. Box 277, Palo Alto, California.

**WANTED**

ANYTHING within reason that is wanted in the field served by Electronics can be quickly located through bringing it to the attention of thousands of men whose interest is assured because this is the business paper they read.

**CHIEF ENGINEER Available**

20 years experience in the development and production of electronic equipment. Qualified in all phases of government contracts.

PW-2258, Electronics  
330 W. 42nd St., New York 18, N. Y.

For sale complete equipment, meters, materials, specifications to make paper dielectric condensers. Opportunity for engineer to start in business. Price in four figures.

BO-2303 Electronics  
330 W. 42nd St., New York 18, N. Y.

**Electronic Engineers****PROJECT ENGINEERS**

Five or more years experience in the design and development, for production, of major components in radio and radar equipment.

**ASSISTANT PROJECT ENGINEERS**

Two or more years experience in the development, for production, of components in radio and radar equipment.

Well equipped laboratories in modern radio plant . . . Excellent opportunity . . . advancement on individual merit.

Baltimore Has Adequate Housing

Send resume to Mr. John Siena:

**BENDIX RADIO DIVISION**  
BENDIX AVIATION CORPORATION  
Baltimore 4, Maryland

**ENGINEERS**

Research and Development  
Career Positions for  
Top Engineers and Analysts

**Senior Electro-Mechanical Engineers:**

At least 4 years experience in Servo-Mechanisms, Analogue Computers, Circuitry Development in Aircraft, Guided Missiles and Fire Control System Design.

**Senior Electronics Engineers:**

4-8 years experience as Project Engineer in Radar Design, System and Circuit Analysis.

**Electronic Engineers:**

2-4 years experience in Antenna and Microwave Design.

Submit detailed resume. Personal interviews will be arranged.

**THE GLENN L. MARTIN COMPANY**  
Baltimore 3, Maryland

**CONTRACT**

ENGINEERING—MANUFACTURING

electronic and electro-mechanical devices  
● developed to meet your specifications  
● manufactured per sample or drawings  
**TELETRONICS LABORATORY, Inc.**  
Westbury, L. I., N. Y.—Westbury 7-1028

Time is money. Save it by referring to our  
**ACCUMULATIVE INDEX FOR ELECTRONICS BIBLIOGRAPHY**  
Simple and Dependable  
Write for descriptive literature  
**TECHNICAL INDEX SERVICE**  
Box 632 Asbury Park, New Jersey

**RCA VICTOR  
Camden, N. J.****Requires Experienced  
Electronics Engineers**

RCA's steady growth in the field of electronics results in attractive opportunities for electrical and mechanical engineers and physicists. Experienced engineers are finding the "right position" in the wide scope of RCA's activities. Equipment is being developed for the following applications: communications and navigational equipment for the aviation industry, mobile transmitters, microwave relay links, radar systems and components, and ultra high frequency test equipment.

These requirements represent permanent expansion in RCA Victor's Engineering Division at Camden, which will provide excellent opportunities for men of high caliber with appropriate training and experience.

If you meet these specifications, and if you are looking for a career which will open wide the door to the complete expression of your talents in the fields of electronics, write, giving full details to:

**National Recruiting Division**  
Box 400, RCA Victor Division  
Radio Corporation of America  
Camden, New Jersey

**SCIENTISTS AND ENGINEERS**

Wanted for interesting and professionally challenging research and advanced development in the fields of microwaves, radar, gyroscopes, servomechanisms, instrumentation, computers and general electronics. Scientific or engineering degree or extensive technical experience required. Salary commensurate with experience and ability. Direct inquiries to Mgr., Engineering Personnel, Bell Aircraft Corporation, P. O. Box 1, Buffalo 5, N. Y.

**WANTED**

Boonton 160A 170A Q Meter, GR916A RF bridge, GR 736A Wave Analyzer. Give details to

W-2372, Electronics  
330 W. 42nd St., New York 18, N. Y.

**WANTED**

Oil, Mica and Bathtub Conds. Rheostats, "AB" Pots and other types. Clean electronic components & equip.

W-2407, Electronics  
330 W. 42nd St., New York 18, N. Y.

**MANUFACTURING SOURCE AND SALES OUTLET  
FOR YOUR PRODUCT**

Financially responsible radio and television components manufacturer selling direct to set manufacturers desires inventions, ideas or any new developments applicable to the television, radio or electronic field, electrical or mechanical. Compensation will be made by purchase, royalty or percentage. All inquiries will be received in absolute confidence.

Address BO-2453, Electronics  
520 N. Michigan Ave., Chicago 11, Ill.

Additional Position Vacant Ads on page 262—Equipment Wanted Ads page 286

## RADAR, COMMUNICATIONS *and* SONAR TECHNICIANS **WANTED**

**For Overseas Assignments**

*Technical Qualifications:*

1. At least 3 years' practical experience in installation and maintenance.
2. Navy veterans ETM 1/c or higher.
3. Army veterans TECH/SGT or higher.

*Personal Qualifications:*

1. Age, over 22—must pass physical examination.
2. Ability to assume responsibility.
3. Must stand thorough character investigation.
4. Willing to go overseas for 1 year.

Base pay, bonus, living allowance, vacation add up to \$7,000.00 per year. Permanent connection with company possible.

*Apply by Writing to*  
**A-1, P. O. Box 3414**  
**Philadelphia 22, Pa.**

Men qualified in RADAR, COMMUNICATIONS or SONAR give complete history. Interview will be arranged for successful applicants.

### SENIOR ELECTRONICS DEVELOPMENT ENGINEER

To engage in original Design & Development of high performance

### ELECTRO-MECHANICAL DEVICES

Formal Electrical Engineering education at or near the Doctorate level & several years experience in actual design of Electro-Mechanical Devices are essential.

Please submit complete resume of education, experience and salary requirements to

*Personnel Department*  
**CURTIS WRIGHT CORP.**  
*Propeller Division*  
**CALDWELL TOWNSHIP, N. J.**

WANTED FOR  
CERAMIC CAPACITOR MANUFACTURER

Engineer familiar with manufacturing techniques, design and development of equipment for use in high speed production of Ceramic Capacitors. Should be capable of assuming complete charge of manufacturing program. Send resume of education, experience, salary desired to

F-58, P. O. BOX 3414  
PHILA. 22, PA.

## ELECTRONICS ENGINEER

Required qualifications of man to be selected:

1. Audio amplifier specialist.
2. Five to ten years experience.
3. Record of successful leadership of an electronics design group.
4. Aggressive but friendly personality.
5. Ability to select best ideas and be able to sell them to supervisors and top management.
6. Experience in sound motion picture would be helpful.

Position to be filled offers rare opportunity to man who can qualify.

*In reply give full details.*

Address P-2434, Electronics  
520 N. Michigan Ave., Chicago 11, Ill.

## SENIOR ELECTRONIC CIRCUIT PHYSICISTS

*for*  
*Advanced Research*  
*and Development*

MINIMUM  
REQUIREMENTS:

1. M.S. or Ph.D. in Physics or E.E.
2. Not less than five years experience in advanced electronic circuit development with a record of accomplishment giving evidence of an unusual degree of ingenuity and ability in the field.
3. Minimum age 28 years.

### Hughes Aircraft Company

Attention: Mr. Jack Harwood  
CULVER CITY, CALIFORNIA

## OPPORTUNITY FOR TELEVISION ENGINEERS

### SENIOR DEVELOPMENT ENGINEER

Man, experienced in commercial design, wanted to supervise development of new receivers for important manufacturer of quality instruments. Must have strong academic and theoretical background.

### JUNIOR TELEVISION ENGINEERS

Men with practical experience and good academic background.

▼  
Write today,  
furnishing complete details  
including salary required, to

▼  
DIRECTOR OF RESEARCH  
& DEVELOPMENT  
**FREED RADIO CORPORATION**  
200 Hudson Street, New York 13, N.Y.

## SEVERAL ENGINEERS

needed by contractor for work at Naval Air Missile Test Center, 50 miles northwest of Los Angeles. College degree and several years experience essential. Radar, computer, or telemetering experience preferable.

**ELECTRONIC ENGINEERING CO.**  
**OF CALIFORNIA**  
2008 West Seventh Street  
Los Angeles 5, California

## MANAGEMENT CONSULTING

Established management consultant seeks an engineer with the following qualifications: educational background in electronics including degree and preferably graduate training. At least 5 years' experience with one or more manufacturers of electronic apparatus or components in one or more of these areas: industrial engineering, production management, plant engineering or design and development. Must be willing to travel. Salary open.

P-2455, Electronics  
520 N. Michigan Ave., Chicago 11, Ill.



# =COMMUNICATIONS EQUIPMENT COMPANY=

## OILCONDENSERS FAMOUS MAKES BRAND NEW

Mfd. Volt Price	Price
15 220AC	\$2.00
5.5 400	.50
1 600	.45
1 600	.98
7 600	1.05
1 750AC	1.60
7 800	1.20
.5 1K	.69
1.5 1K	.75
2 1K	.99
10 1K	.98
15 1K	1.95
25 1.5K	1.05
1 1.5K	.89
1.5 1.5K	.95
2 1.5K	1.05
6 1.5K	2.25
1 2K	1.20
1 2.5K	1.20
.15 4K	2.95
.1 4.8K	2.95
4 5K	2.95
15.15 6K	2.79
15.15 6K	4.95
1 6K	.98
.1 7K	3.39
1 7.5K	2.95
1 7.5K	12.95
15.15 8K	4.95
1 10K	14.95
.0016 15K	7.95
1 15K	30.95
.015 16K	6.95
.25 20K	16.95
.5 25K	36.95
1 25K	83.95
4 50	1.29
1 100	1.15
2.5 100	.23

## 200VDC

2x.1 2ST	.15
2x.1 3TT	.15
2x.1 4ST	.16
2 2ST	.20
.5 2TT	.15
.5 2ST	.15
.5 400VDC	
2x.25 3ST	.21
2x.2 3ST	.21
2x.1 2TT	.20
3x.1 3ST	.25
2x.1 2ST	.26
1 2TT	.19
1 1TT	.19
1 2ST	.23
2 2ST	.26
600VDC	
1 2BT	.20
1 2ST	.21
2x.1 3ST	.27
2x.1 3BT	.26
2x.1 2ST	.25
1 3ST	.25
2x.25 3ST	.23
.25 2TT	.20
1 2ST	.20
2x1 3ST	.35
2 2ST	.40
2 2BT	.39
2 2BT	.39
10000VDC	
1 2ST	.45

## MANY OTHERS

## MICA CONDENSERS

0000VDC EST	
.0015	.36
.0175	.45
.00005	.59
.00137	.59
1200VDC EST	
.000075	.59
.00027	.59
2000VDC EST	
.00003	.98
.01	1.64
2500VDC EST	
.00025	.36
.006	1.38
.003	1.39
.000047	.39
.005	.79
.00054	.39
.00005	.39
3000VDC EST	
.00007	1.59
.0004	1.29
.002	1.60
5000 VDC EST	
.0025	.98
.006	1.65
.0043	2.70
.0002	2.70
.0008	2.70
.0004	2.70
.00075	2.70
.005	2.50

## LINE FILTER, GE

100 Amp Filter w/2x5Mid 50V. 110VAC. Operates on 110VAC. \$1.98 DC.

## KW LINE FILTER

clean up BCI & TVI. With 4-.002 Mid. Cond. Easy to Mount. \$3.95

## RUBBER COVERED CABLE

4-1/3 ft long w/red, blk. & white leads for Mike or Hdset 10 for \$1.00

## STAND OFFS

w/alum base 1 1/4x8"	\$1.25
w/alum base 1x7"	.98
w/alum base 1 1/4x5"	.98
w/alum base 1x4"	.70
w/alum base 1 3/4x3 3/8"	1.69
w/alum base 1 1/2x3"	1.00
IN84XSI. 2 1/4"	1.00
LN81 feed support 1 1/2"	.80
LN82 feed support 3"	1.66
Stand off 3 1/2x1/4"	2.64
Stand off 6 3/4x1/4"	4.04
Spreader 2 1/8x5/8 Sq.	.84
Spreader 2 11/16x7/16 d.	1.04
Thru panel 1 1/4x3/4d.	1.5c
Bowl thru x33. 6 3/4x3/4 d.	1.10
Antenna IN86	15c

## VIBRATORS

TR 1210, 12 vdc, 5 pin.	\$1.00
OAK V-6675, 24-32 vdc, 7 pin	\$1.00
Mal. Type G534C, 12 vdc, 5 pin	\$1.00
Mal. Type G629-C, 12 vdc, 4 pin	\$1.00

## AUTOMATIC CODE EQUIPMENT

TAPE PULLERS, (McElroy)	
TP 890, 110-120 v. AC-DC	\$12.50 ea.
TAPE BRIDGES: (McElroy)	
TP85, complete.	\$3.50
Tape Loops: For TG-8 and TG-9	\$1.00
BLANK CODE TAPE: 8" rolls, 11/16" wide. Per roll.	\$3.50

## LAMPS

Tung Sol #1488 14v 10	60c
Mazda #623 24-28v 10	60c
Tung Sol #1251 24-28v 10	60c
G.E. #LM37 15v 10	60c
Mazda 10w 60v 10	10c ea.
Tung Sol 6CP-81, 6-8v	15c ea.

## WIRE WOUND POTS

20,000 ohms, 10%, 8 watt.	\$ .95
5,000 ohms, 10%, 8 watt.	\$ .95
15,000 ohms, 10%, 4 watt.	\$ .69
Dual 250 ohms, 25 watt.	\$ .98
50 ohms, 25 watt.	\$ .69
1000 ohms, 50 watt, mod J.	\$ .98
300 ohms, 50 watt mod J.	\$ .98
5 ohms, 250 watt, mod L.	\$ .95

## 6-VOLT RELAY PANELS

Comes complete with relays mounted on bakelite panel with 25 terminals:  
1-SPST (NO) 1-DPST (NO)  
1-SPST (NO) 2-DPST (Make 1, Break 1) Board Dim: 10" x 6" W x 2 1/2" H. \$4.95

## T.V. Transformer, 7"

or 9" scope, 3000v/5MA, 720vct/200MA, 6.4/3.7A, 6.4/6A, 5/3A, 1.25/3A, 15V 60 cy input. Price \$3.95

## Universal Output Transformer

Amertran Silcor, PRI: 20,000/16,000/5000/4000 ohms. Sect. 500/15/7.5/5/3.75. 1.25 ohms. Flat 30 db. contin. Flat to 17,000 CY. w/Disp. & Inst. for 6 watt amplifier. \$4.75

## XFRMR POWER SUPPLY KITS

Trans. 1080V/55MA. 6.3V/1.2A. 6.3/1.2A. 2-1 Mfd 2500V 2X2 Tube, Socket, 1-100000 ohm Resis. Price \$6.49  
"BASIC 5" AND 7" TV PWR SUPPLY  
Trans. 2300V/4MA. 2.5/2A. 2-1 Mfd 7500V Pyr. 2x2 Tube. Socket, 1-100000 ohm Resis. \$8.49

## TRANSFORMER 720VCT/250

Ma. 6.4V/8.7A. 6.4V/6A. 5/7 3A. 1.25/3A. \$3.25

## BC-605 Interphone Amplifier

Easily converted to an ideal inter-communications set for office, home-or factory. Original, New w/conversion Diagram. \$4.75

## 932 PHOTO TUBE

Gas Phototube having SI response, particularly sensitive to Red and Near Infrared Radiation. Can be used with incandescent light source. Send for Data. Price \$1.98  
1619-1619-1619  
Octal Base Pentode Aversatille High Perveance Tube. \$2.1c  
5 for \$1.00

## WHOLESALE ONLY

Phone or Write for Quantity & Price DIGBY 9-4124

## ATT. MR. C. ROSEN

1,000,000 Bathtubs	
4,000,000 Micaf	
500,000 Sil. Micaf	
100,000 Oil Cond.	
4,000,000 Resistors	
400,000 Electrolytics	
400,000 H. V. Micaf	
5,000 K. V. Cond.	
150,000 Prec. Resis.	
700,000 Tube Clamps	
1,000,000 An. Connectors	
50,000 Dynamotors	
200,000 Power Xfmrms	
20,000 Chokes	
100,000 Antennas	
50,000 Audio Xfmrms	
100,000 Cy Xfmrms	
100,000 Shock Mts.	
25,000 Magnets	
5,000 Magnets	
50,000 Pulse Xfmrms	
500,000 Control Boxes	
500,000 Tubes	
300,000 Relays	
500,000 An. Connectors	
35,000 Vibrators	
200,000 UG Connectors	
2,000 Scopes	
1,500 Asst. Phones	
20,000 Headsets	
1,000 Mikes	
100,000 Elements	
Tons of Nuts & Bolts	
Screws, Etc.	
1,000 Gibson Girls	
500 BC 375	
Complete	
500,000 Insulators	
150,000 Binding Posts	
200,000 Wafer Switches	
300,000 Ceramicons	
500,000 Ferrule Resis.	
50,000 PL 54	
25,000 JK 26	

## TEST SETS ARMY NAVY

T.S. 33/AP	
T.S. 35/AP	
T.S. 43A-APM3	
T.S. 62/AP	
C.S. 60/AP	
804 Federal Sig. Gen.	

## SCR 584

BC 1056A	
BC 1058A	
BC 1058B	
BC 1086B	
BC 1088A	
BC 1090A	
BC 1090B	
BC 1094A	
BC 1096A	
IRA 71A	
Variable Spacing	
Magnets	
Barco Rotate Jt.	

## TELEPHONE EQUIPMENT

Pike Pole, Telephone, MC123, for Wire Laying 2 sections, 4 1/2 ft. ea. section w/M100 Lock. New Unused. \$5.90  
Telephone Hans Shell, For TSI0 Sound Power W.E. Light weight. \$6.9c  
Tape Bridge TG815: McElroy used for standard B3 White Paper, for Sight Reading and Typewriter transcription. SPECIAL PRICE. \$5.50  
W.E. Teletyp Switchboard #5. Complete Installation. \$20.00 ft. days. NEW EXPORT PACKED. AVAILABLE FOR INSPECTION.

## Ceramicons

Mmt	
1	25
3	27
3.1	35
4	30
5	47
6	70
7	57
8.5	58
11	60
15	62
20	67
24	70
29	220
115	240
125	250
150	350
180	1600
200	

## Soldering Iron 200W

121-130V iron % removable contact. Heats in a minute. Complete with cord & plug. New with stand \$3.95

## BUZZER HIGH FREQ

6V used in B19. Price. \$9c

## MOUNTINGS

MT-5/ARR2	FT-225A
MT-7/ARR2	FT-229A
MT-171A/U	FT-232A
FT-265A	FT-234A
FT-340	MT-85/ARC5
MT-167/U	MT-78/ARC5
FT-308A	MT-62/ARC5
FT-282A	
MT-80/ARC5	
FT-141	

115V/60	600	VCT/200MA
6.3 VCT/5.	5VCT/3A	\$3.95
115V/60	580VCT/30MA	5
VCT/3A		\$2.45
115V/60	1100/250MA.	6.3/6A
		\$6.95
115V/60	24V/1.5A.	\$1.95
115V/60	36V/3.5A	\$2.95

## MANY OTHERS—WRITE

## Birtcher Tube Clamps

926C	
926-16	
926-b1	
926-b2	
926-18	
926-C15	
926-C-13	
926-C-19	926-B-31
926B-16	926C-23
926A-14	926-K2
926A	
926A11	10 \$1.40
Each 15c	100 \$12.00

## SHOCK MOUNTS

No. 1 Square	
No. 2 Square & Diamond	
No. 4 Square & Diamond	
No. 6 Square	
No. 8 Square & Holder	
No. 12 Square & Holder	
No. 15 Square & Holder	
No. 20 Square & Holder	
No. 33 Square	
No. 35 Square & Holder	
No. 10 Square & Holder	
No. 25 Square & Holder	
No. 15 Holder	
No. 55 Holder	

## EE65E Telephone Test Set

To locate any kind of trouble on Tel lines: can be used as telephone. Includes ringing circuit etc. A valuable unit. \$18.95

## EE89A Telephone Repeater

Used to extend range of field telephones. Simplex Teleg. and 20 cycle ringing possible over lines equipped with unit. Supplied w/305 tube. Phone supplied (featherweight) \$9.75

## Loading Coil C114

Same as WE No. 632 but in waterproof case to counter balance cap. in line gives clearer signal. Army used W/W101 & W130 wire. \$5c ea.

## INVERTERS

PE 218-E: Input: 25 28 vdc. 92 amp. Output: 115 v. 350-500 cy 1500 volt-amperes. Dim: 17"x6 1/2"x10" New (as shown) \$29.50

PE 218-H: Same as above except size: 16 1/2" x 6" x 10". \$29.50

PE 208: Input: 28 vdc. 38 amperes. Output: 30 v. 800 cy. 500 volt-amperes. Dim: 13" x 5 1/2" x 10 1/2". New \$22.00

GE 5D21N13A: Input: 28 vdc. 35 amp. Output: 115 v. 400 cy. 485 volt-amperes. Dim: 9" x 4 1/2" diam. New. \$49.95

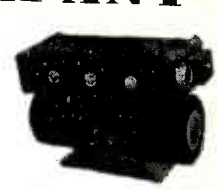

## RF CHOKES

1Mhy/125MA	.23
1.9-2Mhy	.40
2.5Mhy/500MA	.89
3.2Mchy	.10
3.3Mchy	.10
3.6Mchy	.10
5.2Mhy/200MA	.39
5.5Mhy/500MA	.98
6.4Mchy	.10
10Mhy/350MA	.39
20Mchy	.10
94Mhy	.10
10Mchy	.10
115Mhy/150MA.	.39
185Mchy	.10
220Mchy	.18



Helineman Ckt. Bkrs. for AC-DC Operation. .010, 3. 7. 60, 80, 100, 150. Ea. \$1.50

## VOLTAGE REGULATORS

Mfg. Raytheon: Navy CRP-301407: Pri: 92-138 v. 15 amps. 57 to 68 cy. 1 phase. Sec: 115 v. 7.15 amp. \$2 KVA. 96 PF. Contains the following components: Regulator Transformer: Raytheon UX-9545. Pri: 92-138 v. 60 cy. 1. PH. Sec: 200/5 5.5/5.26 amps. 400 v rms test. FILTER REACTOR: 156 hy. 5 amps, 4000 v test. Raytheon UX 9547. TRANSFORMER: Pri: 186 v. 5 amps; Sec: 115 v. 7.2 amps. Size: 12" x 20" x 29". Net Wt. approx. 250 lbs. Entire unit is enclosed in grey metal cabinet with mounting facilities. New, as shown. \$95.00



## RELAYS

Contacts	Rating	Coll Ohms	Mfg.	Price
DPDT 24-28V (8A) vdc	170	100F3	GECR2791B	75c
SPDT 28vdc	175		GECR2791B	75c
3PDT 24-28 vdc	175		GECR2791G	75c
4PST 24 vdc	18			



# COMMUNICATIONS EQUIPMENT COMPANY

## X BAND

Directional coupler, UG-40/U take off, 20 DB.	\$17.50
Directional coupler, APS-6, Type "N" take off, 20 DB, calibrated	17.50
Broad Band Directional coupler, type "N" take off, choke to cover, 23 DB, calibrated	18.50
Directional coupler, APS-31, type "N" take off, 28 DB	17.50
Bi-directional coupler, type "N" take off	22.50
Flexible Section 18" long	12.00
Straight Sections 2 1/2 ft. long choke to cover, silver plated	6.50
Pressure Test Section with 15 lb. gauge and pressurizing nipple	10.00
Bulk Head Feed Through, choke to cover	12.00
Mitered Elbow, choke to cover or choke to choke	12.00
Right Angle Bend 2 1/2" Radius, choke to cover	12.00
90° Twist, 6" long	7.50
45° Twist, 6" long	7.50
90° Twist, 5" long with pressurizing nipple	7.50
15° Bend 10", Choke to cover	4.50
5 ft. Sections UG-39 to UG-40, silver plated	9.50
180° Bend, 26" Choke to cover 2 1/2" radius	5.00
SWR Measuring Section 4" long, 2 type "N" probes mounted full wave apart 1/4 x 3/8" guide	8.50
WE attenuator 0 to 20 DB, less cards, ball size guide	12.50
90° Bend E Plane 18"	4.00
Rotary Joint, choke to choke	10.00
Rotary Joint, choke to choke with deck mounting	10.00
TR-ATR Duplexer Section for 1B24 and 724B	12.50
Wavemeter-Thermistor Mtg. Sect.	6.00
2K25/723 AB Receiver, Local Oscillator Klystron Mount, complete, with Crystal Mount, Iris Coupling and Choke Coupling to TR	22.50
TR-ATR Duplexer Section for above	8.50
723AB Mixer—Beacon Dual Oscillator Mount with Crystal Holder, used	12.00
723AB Mixer—Beacon Dual Oscillator Mount with Matching Slugs and tunable termination, new	24.50
Bi-Directional Coupler, type "N" termination, 26 DB, calibrated, 1/4 x 3/8" guide	24.50
12" Flexible Section 1/4 x 3/8" guide	10.00
Crystal Mount in Waveguide	17.50
SO-3 Echo Box, Transmission type cavity with bellows	28.50
180° Bend with pressurizing nipple	5.00
"S" Curve 18" long	5.00
"S" Curve 6" long	3.25
APS-31 Mixer Section for mounting two 2K25's, Beacon Reference Cavity, 1B24 TR Tube	42.50
Transition 1 x 1/2 to 1/4 x 3/8", 14" long	8.00
Receiver Front End, complete, C/O Dual 723AB Klystron mount, TR-ATR Duplexer Section, 2 stage 30 MC. Preampifier, new, with ALL tubes	59.50
Random Lengths of Waveguide 6 to 18" long	1.00 per ft.

## RADAR SETS

APS-2 Airborne 10 CM, Major Units	New	\$500
APS-4 Airborne 3 CM, Compl.	Used	1800
APS-15 Airborne 3 CM, Major Units	New	500
SD-4 Submarine 200MC, Compl.	New	1100
SE Shipboard 10 MC, Compl.	New	1200
SF-1 Shipboard 10 CM, Compl.	Used	2800
SJ-1 Submarine 10 CM, Compl.	Used	1500
SL-1 Shipboard 10 CM, Compl.	Used	1700
SN Portable 10 CM, Compl.	Used	600
SQ Portable 10 CM, Compl.	Used	650
SO-1 Shipboard 10 CM, Compl.	Used	1500
SO-8 Shipboard 10 CM, Compl.	Used	1500
Mark 4 Gunlaying 800MC, Less Ant.	Used	850
Mark 10 Gunlaying 10 CM, Compl.	New	2000
Less Rack	New	1500
Less Rack	Used	1100
CPN-3 Beacon 10 CM, Major Units	Used	1200
CPN-6 Beacon 3 CM, Compl.	New	Write
CPN-8 Beacon 10 CM, Compl.	New	2000
Less Ant.	New	1400
SCR-533 IFF/AIR 500MC Search/Trailer	New	1200
Airborne Radar 500MC, Compl. Altimeter	New	1750
SCR 663-73 Sperry searchlight training, aircraft, tracking, 10 CM 360° horizontal sweep 90° vert. sweep. Used		\$450.00
APS15 Consists of transmit., mod. rec. ind. ant., 400 cy pwr unit, less control boxes & cable, new.		\$500.00
Mark 8 Model 2 Gyro stable element designed for use in stabilizing large caliber naval gun.		\$2,000.00

# RADAR

## COUPLERS—UG—CONNECTORS

UG/15U	\$.75	UG 116 Cover & Coupling Ring	\$1.95
UG206U	.90	UG 117 Choke	2.50
UG87U	1.25	UG 51 Cover	1.00
UG27U	1.69	UG 52 Choke	1.35
UG21U	.89	UG 210 Cover	1.85
UG167U	2.25	UG 212 Choke	2.40
UG29U	.90	UG 40U Special for Duplexer	.70
UG254U	1.69	1/2 Coax Female Ring Thd or Unthd	.50
UG86U	1.40	1/2 Coax Male Fitting thd	.95
UG342U	3.25	Conc. Choke Flange	.50
UG85U	1.45	X Band Flat Contact Flange	1/8
UG58U	.60	Thk	.25
UG9U	.89	Contact Ring 1/4" Thk 1 1/2" dia.	.25
UG102U	.45	UG 53/U, Cover	4.00
UG103U	.45	UG 54/U, Cover	4.75
UG255U	1.65	UG 55/U, Choke	4.75
UG 40/U Spec. for		UG 56/U, Choke	4.75
Mixer Assy.	\$.75	UG 65/U, Contact	6.50
UG 40A	1.10	UG 149/U, Cover	3.00
UG 343 Cover	2.35	UG 148/U, Choke	4.00
UG 344 Choke	3.00	UG 150/U, Contact	3.00
UG 425 Contact	2.00	UG 39/U, Cover	.80
		UG 40/U, Choke	.80

Various other types available. Write us your needs.

## S BAND

90° Twist, circular cover to circular cover	\$25.00
Magnetron to Waveguide Coupler with 721A Duplexer Cavity, gold-plated	\$45.00
Waveguide Switch—Transposes one input to any of three outputs. Standard 1 1/2" x 3" square flanges. Complete with 115V drive motor. Rateon CRT-24AAS, new	\$150.00
721A TR Box complete with tube and tuning plungers	\$12.50
McNally Klystron Cavities for 70B or 2K28. Three types available	\$4.00
Right Angle Bend 5 1/2 ft. over-all with 8" slotted section	\$21.00
Pick-up Dipole in Lucite Ball with Sperry Fitting	\$4.50
F-29/SPR-2 Filters, Type "N", input and output	\$12.50
726 Klystron Mount, Tunable output, to type "N" complete, with socket and mounting bracket	\$12.50
WAVEGUIDE TO 3/8" RIGID COAX "DORKNOB" ADAPTER, CHOKE FLANGE, SILVER PLATED	\$32.50
BROAD BAND WAVEGUIDE DIRECTIONAL COUPLER, 27 db, Navy type CABV-47AAN, with 4 in. slotted section	\$32.50
SQ. FLANGE to rd choke adapter, 18 in. long OA 1 1/2 in. x 3 in. guide, type "N" output and sampling probe	\$27.50
Crystal Mixer with tunable output TR pick up loop, type "N" connectors, Type 62ABH	\$14.50
Slotted line probe. Probe depth adjustable, Sperry connector, type CPR-14AAO	\$9.50
Coaxial slotted section, 3/8" rigid coax with carriage and probe	\$25.00
Right Angle Bend 6" radius E or H plane	\$27.50
Right Angle Bend 3" radius E or H plane—Circular flanges	\$17.50
AN/APR5A 10 cm antenna equipment consisting of two 10 CM waveguide sections, each polarized, 45 degrees	\$75.00 per set
PICKUP LOOP, Type "N" Output	\$2.75
TR BOX Pick-up Loop	\$1.25
POWER SPLITTER: 726 Klystron input dual "N" output	\$5.00
"S" BAND Mixer Assembly, with crystal mount, pick-up loop, tunable output	\$3.00
721-A TR CAVITY WITH TUBE. Complete with tuning plungers	\$12.50
10 CM OSC. PICKUP LOOP, with male Homedell output	\$2.00
10 CM FEEDBACK DIPOLE ANTENNA, in lucite ball, for use with parabola 7/8" RIGID COAX INPUT	\$8.00
PHASE SHIFTER, 10 CM WAVEGUIDE, WE TYPE FS-68316, E PLANE TO H PLANE, MATCHING SLUGS, MARK 4	\$95.00
721A TR cavities. Heavy silver plated.	\$2.00 ea.

## 7/8" RIGID COAX

Directional coupler, Type "N" take off	\$22.50
Magnetron Coupling with TR Loop, gold-plated	\$7.50
Flexible Section Male to Female	\$3.50
Right angle bend 15" over-all	\$3.50
Sperry Rotating Band, pressurized	\$22.50
5 Ft. Lengths Stub Supported, gold-plated, per length	\$7.50
Short Right Angle Bends (for above)	\$2.50
Rigid Coax to Type "N" Adaptors	\$8.00
Test Block CU-60/AP	\$8.00
CG-54/U—4 foot flexible section 1/4" IC pressurized	\$15.00
7/8 RIGID COAX. Bead Supported 1/4" I.C.	\$12.00
SHORT RIGHT ANGLE BEND 1/4" I.C.	\$2.50
Rotating Joint, with deck mounting 1/4" I.C.	\$15.00

## THERMISTORS

D-167352 (tube)	\$.95
D-170396 (bead)	\$.95
D-67613 (button)	\$.95
D-104690 for MTG in "X" band Guide	\$2.50
D-167018 (tube)	\$.95

## VARIATORS

D-170225	\$1.25
D-167176	\$.95
D-168087	\$.95
D-171812	\$.95
D-171528	\$.95
D-168549	\$.95
D-168442	\$.95
D-163293	\$1.25
D-98428	\$2.00
D-16187A	\$2.85
D-171121	\$.95
SA (12-43)	\$1.50
D-167620	\$3.00
D-105398	\$2.25

WRITE FOR C.E.C. MICRO-WAVE CATALOG NOW AVAILABLE

## MICROWAVE COMPONENTS

← COMPLETELY NEW LISTINGS →

## TEST EQUIPMENT

CG-176/AP Directional coupler X Band, 20 DB nominal, type "N" take off, choke to choke, silver-plated	\$17.50
X Band 1 1/2" x 3/8" absorption type wavemeter, micrometer head, 6000 to 8500 mc. Demornay-Budd #356	\$185.00
C Band "T" gold-plated at	\$97.00
C Band Flap attenuator Demornay-Budd type #339, gold-plated	\$25.00
X Band 1 1/2" x 3/8" Klystron mount with tunable form, gold-plated	\$75.00
X Band 1 1/2" x 3/8" low power load, gold-plated	\$45.00
X Band 1 1/2" x 3/8" waveguide to type "N" adaptor, gold-plated	\$22.50
X Band 1 1/2" x 1/2" "T" Section, gold-plated	\$55.00
Dehydrator Unit CPD 10137 Automatic cycling. Compressor to 50 lbs. Compl. for Radar XSMN. Line New	\$425.00
H. V. Pwr. Supply, 1500V V 30 MA, DC Bridge Rect. Pwr. Sply. Oper. F.M. 115 V 60 cy	\$115.00
SO-3 Receiver, 30 mc. IF. 6 stages 6AC7, 10 mc. Band width inpt. 5.1 mc. B.W. per stg., 9.6 volt gain per stage as desc. In ch. 13 vol. 23 M.I.T. Rad. Lab. Series	\$99.50
APS-2 10CM RF HEAD COMPLETE WITH HARD TUBE (715B) Puts on 714 Magnetron 417A Mixer all 7/8" rigid coax. Incl. revr. front end.	\$210.00

## DE MORNAY BUDD

ALL FORMER STOCK AVAILABLE Through COMMUNICATIONS EQUIPMENT CO.

## MODEL TS-268/U

Test set designed to provide a means of rapid checking of crystal diodes IN21, IN21A, IN21B, IN23, IN23A, IN23B. Operates on 1/2 volt dry cell battery. \$35.00

3 x 6 x 7. New

3 cm. wavemeter. Ordnance type micrometer head new: Absorption type \$85.00

9000-9500 MCS Transmission type \$92.50

SL wavemeter, Type CW60ABM \$125.00

10CM ECHO BOX CABV 14ABA-1 of OBU-3, 2890 MC to 3170 MCS direct reading micrometer head. Type Ring prediction scale plus 9% to minus 9%. Type "N" input. Resonance indicator meter. New and Comp. w/access. Box and 10 CM Directional Coupler \$350.00

10 cm horn assembly consisting of two 5" dishes with dipoles feeding single type "N" output. Includes UG28/U type "N" "T" Junction and type "N" pickup probe. Mtg. cable. New \$15.50

10 cm. cavity type wavemeters 6" deep, 6 1/2" in diameter. \$64.50 ea.

10 cm. echo box. Part of SFI Radar W/115 volt DC tuning motor Sub SJ 1118A0 \$47.50

W. E. 1138. Signal generator. 2700 to 2900 Mc. range. Lighthouse tube oscillator with attenuator & output meter. 115 VAC input req. Pwr. supply. With circuit diagram \$150.00



TS 89/AP Voltage Divider. Ranges 100: 1/2 for 2000 to 2000v. 10:1 for 200 to 2000v. Input Z 2000 ohms. Output Z 4 meg ohms flat response 150 cy to 5 meg cy. \$42.50

AS14/AP cm. Pick up Dipole with "N" Cables. \$4.50

TS 235 UP Dummy Load. \$87.50

10 cm Wavemeter. WE type B 435490 Transmission type. Type N. Fittings. Vee-der Root Micrometer dial, Gold Plated W/Calib. Chart P/O Freq. Meter X66404A. New \$99.50

## K BAND

APS-34 Rotating Joint	\$49.50
Right Angle Bend E or H Plane; specify combination of couplings desired	\$12.00
45° Bend E or H Plane. Choke to cover	\$12.00
Directional coupler CU-103/APS 32	\$49.50
Mitered Elbow, cover to cover	\$4.00
TR-ATR Section, choke to cover	\$4.00
Flexible Section 1" choke to choke	\$5.00
"S" Curve choke to cover	\$5.00
Adaptor, round to square cover	\$5.00
Feedback to Parabola Horn with pressurized window	\$27.50
Low Power Load, less cards	\$18.50
K Band Mixer Block	\$45.00
Waveguide 1/2 x 1/4"	\$1.00 per ft.
Circular Flanges	\$5.50
Flange Coupling Nuts	\$5.00
Slotted line, Demornay-Budd #397, new	\$450.00
90° Twist	\$10.00
"K" Band Directional Coupler CU104/APS-34 20 DB	\$49.50 ea.

All merch. guar. Mail orders promptly filled. All prices F.O.B. N. Y. C. Snd MO or Chk. Only shipping chgs sent C.O.D. Rated Concerns send P.O.

# COMMUNICATIONS EQUIPMENT CO.

131 Liberty St., New York, N. Y. Dept. E4

P. J. PLISHNER

Phone: Digby 9-4124



# COMMUNICATIONS EQUIPMENT COMPANY

## PULSE EQUIPMENT

### PULSE TRANSFORMERS

- G.E.K.-2745 ..... \$39.50
- G.E.K.-2744-A. 11.5 KV High Voltage, 3.2 KV Low Voltage @ 200 KW oper. (270 KW max.) 1 microsec. or 1/4 microsec. @ 600 PPS. .... \$39.50
- W.E. #D166173 HI-Volt input transformer, W.E. impedance ratio 50 ohms to 900 ohms, Freq. range: 10 kc to 2 mc. 2 sections parallel connected, potted in oil ..... \$36.00
- W.E. KS 9800 input transformer. Winding ratio between terminals 3-5 and 1-2 is 1:1, and between terminals 6-7 and 1-2 is 2:1. Frequency range: 380-520 c.p.s. Permalloy core ..... \$6.00
- G.E. #K2731 Repetition Rate: 635 PPS, Pri. Imp: 50 Ohms Sec. Imp: 450 Ohms, Pulse Width: 1 Microsec. Pri. Input: 9.5 KV PK. Sec. Output: 28 KV PK. Peak Output: 800 KW, Rfltr 2.75 Amp. .... \$64.50
- W.E. #D169271 HI Volt input pulse Transformer. \$27.50
- G.E. K2450-A. Will receive 13KV, 4 micro-second pulse on pri., secondary delivers 14KV. Peak power out 100KW G.E. .... \$34.50
- G.E. #K2748A. Pulse input, line to magnetron. \$36.00
- #9262 Utah Pulse or Blocking Oscillator XFMR. Freq. limits 790-810 cy-3 windings turns ratio 1:1:1 Dimensions 1 13/16 x 1 1/4 x 19/32. .... \$1.50
- Pulse 131-AWP L-421435 ..... \$6.00
- Pulse 134-BW-2F L-440895 ..... \$2.25
- RAY-WX4298F ..... \$39.50
- G.E.—K6824730 ..... \$50.00
- G.E.—K9216945 ..... \$50.00
- 352—7190 ..... 352—7178
- 352—7250-2A ..... 352—7251-2D

### PULSE NETWORKS

- 15A—4-400-50: 15 KV, "A" CKT, 1 microsec., 400 PPS, 50 ohms imp. .... \$42.50
- G.E. #E3-5-2000-50P2T, 6KV, "E" circuit, 3 sections, .5 microsecond, 2000 PPS, 50 ohms impedance ..... \$6.50
- G.E. #3E (3-84-810; 8-2-24-405) 50P4T; 3KV, "E" CKT Dual Unit: Unit 1, 3 Sections. .84 Microsec. 810 PPS, 50 ohms imp.; Unit 2, 8 Sections, 2.24 microsec. 405 PPS, 50 ohms imp. .... \$6.50
- 7.5E3-1-200-67P, 7.5 KV, "E" Circuit, 1 microsec. 200 PPS, 67 ohms impedance, 3 sections. .... \$7.50
- 7.5E4-16-60-67P, 7.5 KV, "E" circuit, 4 sections, 16 microsec. 60 PPS, 67 ohms impedance. .... \$15.00
- 7.5E3-3-200-6PT, 7.5 KV, "E" Circuit, 3 microsec. 200 PPS, 67 ohms imp., 3 sections. .... \$12.50

### DELAY LINES

- D-163169 Delay Line Small quantity available. .... \$50.00
- D-168184: .5 microsec. up to 2000 PPS, 1800 ohm term. .... \$4.00
- D-170499: .25/.50/.75. microsec. 8 KV. 50 ohms Imp. .... \$16.50
- D-165997: 1/4 microsec. .... \$7.50

### SUPERSONICS

- QCU Magneto striction head RCA type CR 278225—New ..... \$95.00
- Stainless Steel streamlining housings for above \$18.50
- QBG Driver Amplifier New ..... \$200.00
- QCU Magneto striction head, coil plate assembly, new ..... \$14.50
- QCQ-2/QCS Magneto striction head coil plate assembly ..... \$14.50
- QCQ2 Sonar complete set—Write for details
- QC-RCA magneto striction head assy. consists of coil, plate, neckle diaphragm plate, milled steel body unassembled ..... \$65.00
- Supersonic Oscillator RCA I-7-27 Kc. Rec. Driver, Osc. 115 V 60 cy. AC. Designed for use w/200 watt driver. New less tubes ..... \$39.50
- WEA-1 Console, Consists of Rec. Ind. Osc. Remote training control 200 watt driver amp. I-7-27 kc range ..... \$450.00
- QCQ 2 Console Sub. Sig. Co. .... \$450.00
- QBF Sonar mfg. WE complete console consists of 10-10 kc rec. driver osc. ind. & control unit, and driver amplifier 22-28 kc. Write
- QJA Sonar QBF w/QJA adaptor kits w/cathode ray tube indication. Write

- I.F.F. 1 KW Pulsed Output Pkg. Tunable 154-186 mc. adj. modulating pulses 4-10 micro sec. comp. 115v 60cy ac pwr. supply. Vidio output receiver. New w/tubes. .... \$350.00
- Wavemeter for above. .... \$75.00
- Dipole Array for above. .... \$85.00
- BC800 XMTR Revr. Unit New ..... \$55.00
- BC 929 Indicator New ..... \$35.00

### PULSE EQUIPMENT

- MIT. MOD. 3 HARD TUBE PULSER: Output Pulse Power 144 KW (12 KV at 12 Amp). Duty Ratio: 001 max. Pulse duration: 5, 1.0, 2.0 microsec. Input voltage: 115 v. 400 to 2400 cps. Uses 1-715B, 4-829-B, 3-72's, 1-73. New w/tubes ..... \$110.00
- APQ-13 PULSE MODULATOR. Pulse Width .5 to 1.1 Micro Sec. Rep. rate 624 to 1348 Pps. Pk. pwr. out 35 KW Energy 0.018 Joules. .... \$49.00
- TPS-3 PULSE MODULATOR. Pk power 50 amp. 24 KW (1200 KW pk); pulse rate 200 PPS 1.5 microsec. pulse line impedance 50 ohms. Circuit series charging version of DC Resonance type. Uses two 705-A's as rectifiers. 115 v. 400 cycle input. New with all tubes ..... \$49.50
- APS-10 MODULATOR DECK. Complete, less tubes ..... \$75.00
- APS-10 Low voltage power supply less tubes. .... \$18.50
- BC 1203B Loran pulse modulator. .... \$125.00
- BC 758A Pulse modulator ..... \$395.00
- 725A magnetron pulse transformers. .... \$18.50 ea.

### MAGNETRONS

Tube	Frg. Range	Pk. Pwr. Output	Price
2127	2965-2992 mc.	275 KW.	\$8.50
2131	2820-2860 mc.	265 KW.	\$25.00
2121 A	9345-9405 mc.	50 KW.	\$25.00
2122	3267-3333 mc.	265 KW.	\$25.00
2126	2992-3019 mc.	275 KW.	\$25.00
2132	2780-2820 mc.	285 KW.	\$25.00
2137			\$45.00
2138	3249-3263 mc.	5 KW.	\$35.00
2139	3267-3333 mc.	87 KW.	\$35.00
2140	9305-9325 mc.	10 KW.	\$65.00
2149	9000-9160 mc.	58 KW.	\$85.00
2134			\$55.00
2161	3000-3100 mc.	35 KW.	\$65.00
2162	2914-3010 mc.	35 KW.	\$65.00
3131	24,000 mc	50 KW.	\$55.00
5130			\$39.50
714AY			\$25.00
718DY	2720-2890 mc.	250 KW.	\$25.00
720BY	2800 mc.	1000 KW.	\$50.00
720CY	2860 mc.	1000 KW.	\$50.00
725-A	9345-9405 mc.	50 KW.	\$25.00
730-A	9345-9405 mc.	50 KW.	\$25.00
728	AY, BY, CY, DY, EY, FY, GY		\$50.00
700	A, B, C, D		\$50.00
706	AY, BY, DY, EY, FY, GY		\$50.00
Klystrons. 723A/B \$12.50; 707B \$20.00			
W/Cavity			
417A	\$25.00	2K41	\$65.00

### MAGNETRON MAGNETS

Gauss	Pole Diam.	Spacing	Price
4850	3/4 in.	5/8 in.	\$12.50
6200	3/4 in.	3/4 in.	\$17.50
1300	1 1/8 in.	1 1/8 in.	\$12.50
1860	1 1/8 in.	1 1/8 in.	\$14.50

Electromagnets for magnetrons ..... \$24.50 ea.  
 GE Magnets type M7765115, G1 Distance Between pole faces variable. 2 1/2" (1900 Gauss) to 1 1/2" (2200 Gauss)  
 Pole Dia. 1 1/8" New Part of SCR 584. .... \$34.50



### "CW" MAGNETRONS

- QK 62 ..... 3150-3375 mc
- QK 59 ..... 2675-2900 mc
- QK 61 ..... 2975-3200 mc
- QK 60 ..... 2800-3025 mc.
- Each \$65.00
- New, Guaranteed QK 915 Raytheon ..... \$150.00

### FILAMENT TRANSFORMER

- for above 115V/60 cy Pri; four 6.3V/4A Sec. 5000VLT. .... \$27.50
- Magnetron Kit of four QK's 2675-3375 MC Inc. w/transformer. .... \$250.00

### PRECISION CAPACITORS

- D-163707: 0.4, mfd @ 1500-vdc. —50 to plus 85 deg C ..... \$4.50
- D-163035: 0.1 mfd @ 600 vdc, 0 to plus 65 deg C. \$2.00
- D-170908: 0.152 mfd, 300 v, 400 cy, —50 to plus 85 deg C ..... \$2.50
- D-164960: 2.04 mfd @ 200 vdc, 0 to plus 55 deg C. \$2.50
- D-168344: 2.16 mfd @ 200 vdc, 0 to plus 55 deg C. \$3.00
- D-161555: .5 mfd @ 400 vdc, —50 to plus 85 deg C ..... \$3.00
- D-161279: 1 mfd @ 200 vdc, temp comp —40 to plus 65 deg C. .... \$12.50

### YD-2 MARKER BEACON EQUIPMENT.

Comp'l. Installation in Trailer w/Gas Generator—WRITE

### 30' US ARMY SIGNAL CORPS RADIO MASTS

Complete set for erection of a full flat top antenna. Of rugged plymold construction telescoping into 3 ten-foot sections for easy stowage and transportation. A perfect set-up for getting out. Supplied complete: 2 complete masts, hardware, shipping crate. Shipping wt. approx. 300 lbs. Sig Corps #2A289-223-A. New ..... \$39.50 per set

### MICROWAVE ANTENNAS



- AN-122 Dipole Assy. .... \$22.50
- LP-21-A ADF Loop W/Selsyn and Housings, New ..... \$8.00
- DAK Bellino Tossy DF Loops. .... \$125.00
- Adcock DF Arrays, Complete. .... \$65.00
- SA Radar 200 MC Bod Springs Complete with Pedestal, Less Drive ..... \$600.00
- Dish for Parabola 30" ..... \$4.85
- APS-15 Antennas. New ..... \$99.50
- AN MPG-1 Antenna. Rotary feed type high speed scanner antenna assembly, including horn parabolic reflector. Less internal mechanisms. 10 deg. sector scan. Approx. 12'L x 4'W x 3'H. Unused. (Gov't Cost—\$4500.00) ..... \$250.00
- APS-4 3 cm. antenna. Complete. 1 1/2" dish. Cutler feed dipole directional coupler, all standard 1" x 1/2" waveguide. Drive motor and gear mechanisms for horizontal and vertical scan. New, complete. .... \$65.00
- AN/TPS3. Parabolic dish type reflector approx. 10' diam. Extremely lightweight construction. New in 3 carrying cases ..... \$89.50
- RELAY SYSTEM PARABOLIC REFLECTORS: approx. range: 2000 to 6000 mc. Dimensions: 4' x 3' rectangle, new ..... \$35.00
- TDY "JAM" RADAR ROTATING ANTENNA. 10 cm. 30 deg. beam. 115 v.a.c. drive. New ..... \$109.00
- DBM ANTENNA. Dual, back-to-back parabolas with dipoles. Freq. coverage 1,000-4,500 mc. No drive mechanism ..... \$65.00
- AS125/APR Cone type receiving antenna. 1080 to 3208 megacycles. New ..... \$4.50
- I40-640 MC. CONE type antenna, complete with 25' sectional steel mast, guys, cables, carrying case, etc. New ..... \$49.50
- ASD 3 cm. antenna, used, exc. cond. .... \$49.50
- YAGI ANTENNA AS-46A. APG-4, 5 elements ..... \$14.50 ea.
- AS17/APS 10 CM Antenna. APS-2 30 Inch Dish with 3/4 Coax Dipole and fittings. New and Compl. with 24 V DC Drive motor, selsyn. 360 Deg. Rotation and Vertical Tilt ..... \$94.50
- RC-224 Antenna. 10 CM. 30" Dish P/O. SCR-717 Radar, New and Complete. .... \$94.50

### R. F. EQUIPMENT

- LHTR. LIGHTHOUSE ASSEMBLY. Part of RT-39 APG 5 & APG 15. Receiver and Trans Cavities w/ assoc. Tr. Cavity and Type N CPLG. To Revr. Uses 2C40, 2C43, 1B27, Tunable APX 2400-2700 MCS. Silver plated ..... \$49.50
- APS-2 10CM RF HEAD COMPLETE WITH HARD TUBE (715B) Pulser. 714 Magnetron 417A Mixer all 7/8" rigid coax. incl. revr. front end. .... \$210.00
- Beacon lighthouse cavity 10 cm with minlature 28 volt DC FM motor. Mfg. Bernard Rice. .... \$47.50 ea.
- T-128-/APN-19 10 cm. radar Beacon transmitter package, Used, less tubes. .... \$59.50 ea.
- Pre-Amplifier cavities type "M" 7410590GL. to use 446A lighthouse tube. Completely tunable. Heavy silver plated construction. .... \$37.50 ea.
- RT/32APS 6A RF HEAD. Compl. with 725A Magnetron magnet pulse xfmr. TRA-ATR. 723 A/B local osc. and beacon mount, pre amplifier. Used but good cond. .... \$97.50
- AN/APS-15A "X" Band compl. RF head and mod. Incl. 725-A mag and magnet, two 723A/B klystrons (local osc. & beacon) 1B24, TR, revr ampl. duplexer, HV supply blower, pulse xfmr. Peak Pwr Out: 45 KW apx. input: 115, 400 cy. Modulator pulse duration .5-2 microsec. apx. 13KV, PK, Pulse, with all tubes incl. 715B, 829B, BKR 73, two 72's. Complete pkg. .... \$350.00
- S BAND AN/APS2. Complete RF head and modulator. Including magnetron and magnet, 417A mixer, TR receiver duplexer, blower, etc., and complete pulser. With tubes, used, fair condition. .... \$75.00
- ASB-500 Megacycles Radar Receiver with two G1 446 lighthouse cavities, new less tubes. .... \$37.50
- 10 CM Rec Assy. Less Local OSC. Tube. Consists of mixer stabilizer cavity 30 MC preamp AFC, Inc. Amp. plugs & cables p/o APS2. .... \$37.50
- SCR-520 RF Head Compl. with Hard Tube Pulser c/o 2 Aluminum Drums MTD ..... \$350.00
- In Tandem. Compl. W/Tubes ..... \$350.00
- Mark 4 Radar Console (FD)
- Compl. "L" Band RF Pkg. c/o Magnetron OSC. Pulser, Revr.
- H.V. Power Supply, Complete ..... \$850.00
- 115 V. 60 cy. operation

### MICROWAVE ANTENNA RF EQUIPMENT

All merch. guar. Mail orders promptly filled. All prices, F.O.B. N.Y.C. Send M.O. or Chk. Only shipping chgs. sent C.O.D. Rated Concerns send P.O.

## COMMUNICATIONS EQUIPMENT CO.

131 Liberty St., New York, N. Y. Dept. E4 P. J. PLISHNER Phone: Digby 9-4124

first time in RHS history!  
Special Purchase

**SALE!**

while quantities last!

Transmitting—Cathode Ray—Special Purpose  
**TUBES**  
Brand New! Standard Brands! No Seconds!

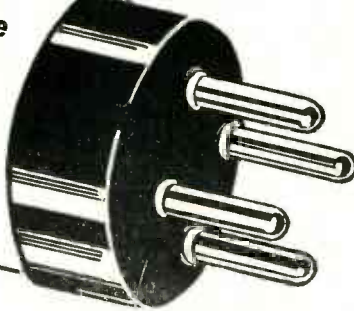

We made a once-in-a-lifetime purchase—and now you can benefit by the terrific savings. No need to tell you these are the most sensational values in our history! Just look at the listing below... compare the prices... you'll know what we mean when we say that you may never again come across a real savings opportunity like this!

**DIODE GAS RECTIFIERS**

4B26	\$ 3.49	8661R	\$ .98
249C	1.49	869B	26.50
575A	11.95	872A	1.12
816	.99	RX21	2.39
866A	1.05	RX120	8.95

**PENTODES**

307A/RK75	\$3.69	807	1.09
713A	.79	837	\$1.19
717A	.49	1613	.49
802	4.19	1619	.15
803	2.95	1851	.69
804	7.95	EF50	.39

**UHF TRIODES**

2C40	\$2.95	703A/368AS	\$1.89
2C43	7.95	708A	3.59
2C44	.98	826	.39
2C46	6.95	8012	.89
3C24/24G	.35	GL434A	2.69
388A	.47	HY615	1.19
527	5.95	VT127A/100TS	1.95

**THYRATRONS**

2D21	\$ .89	2051	\$ .39
3C23	2.19	COJ	3.65
3C31/C1B	1.69	FG17	2.69
3C45	12.95	FG27A	6.95
884	1.19	FG81A	3.29
885	1.19	FG105	8.95
2050	1.19	FG172	13.95

**VOLTAGE REGULATORS**

0A3/VR75	\$ .93	0C3/VR105	\$ .69
0B3/VR90	.65	0D3/VR150	.49
	874		.39

**ACORNS**

954	\$ .16	958	\$ .22
955	.25	959	.35
956	.25	9004	.24
957	.22	9005	1.39

**TRIODES**

2C22/7193	\$ .15	811	\$ 1.98
2C26A	.15	812	2.45
3C22	39.50	814	1.98
614	4.49	833A	33.95
10Y	.19	838	1.98
30 spec	.19	841	.29
45 spec	.19	843	.29
75TL	3.89	845	3.85
100TH	10.49	851	12.95
211	.25	1626	.25
250TH	18.75	8005	4.75
304TH	3.49	8011/WL538	.25
304TL	1.29	8014	22.50
316A	.29	8025	3.69
450TH	16.95	F123A	7.95
710A	.25	F127A	15.95
800	1.49	F128A	89.50
801A	.19	F862A	397.50
805	3.65	HYE148	.29
808	.99	ML101/GL605	49.50
809/3C30	1.89	WL530	12.95
810	7.95		

**DIODE VACUUM RECTIFIERS**

3B24	\$1.49	8013	\$ 1.39
3B26	1.49	F660/WL562	49.50
15R	.49	RK72	.59
100R/8020	.89	RK73	.59
GL451	.89	VD111	.49
250R	5.95	WL531	4.75
371A	.39	WL616	37.50
371B	.49	KC4	37.50
705A	.69	ML100	37.50
1616	.49	F606	37.50

**MINIATURES**

9001	\$ .32	9003	\$ .33
9002	.25	9006	.15

**CATHODE RAY TUBES**

2AP1	\$3.89	5CP1	\$1.29
3AP1	4.59	5CP7	2.95
3BP1	2.39	5FP7	1.19
3CP1	1.39	5GP1	2.98
3DP1	1.79	5JP1	29.95
3DPI-S2A	2.79	5IP2	8.95
3GP1	5.95	5LP1	12.95
4AP10	2.98	7BP7	3.49
5AP1	2.95	9LP7	1.98
5AP4	2.95	902	3.39
5BP1	1.85	905	2.49
5BP4	2.39	908/3AP1	4.95

**CRYSTAL RECTIFIERS**

IN21	\$ .49	IN23A	\$ .79
IN21A	.89	IN23B	1.89
IN21B	.89	IN27	.89
IN23	.59	IN34	.82

**KLYSTRONS**

2K25/723AB	\$22.50	723A/B	\$12.95
2K28	24.95	726A	6.75
417A	8.95	726B	29.50
707B	14.95	726C	49.50

**TWIN PENTODES**

3E29	\$8.95	829UHF	\$7.45
815HF	1.59	832A	4.89

**TETRODES**

3D21A	\$ .98	RK65/5D23	24.50
4-65A	14.29	715B	6.59
4-125A	26.05	715C	19.95
4-200A	36.25	813	6.85
4E27/257B	12.45	860	14.95
5D21	21.45	861	9.49
350B	1.39	865	.79
715A	\$ 5.49	1614	1.35

**GAS SWITCHING TUBES**

1B24 TR	\$4.59	1B23	8.75
1B26 TR	2.79	1B36 anti TR	3.95
1B27 TR	7.95	721A anti TR	3.98
1B29	.79	724B anti TR	2.49
1B32/532A	1.89	1960/S836 diode.	.89

**PHOTOTUBES**

1P24	\$ .59	930	\$ .98
1P36	2.98	931A	2.39

**TWIN TRIODES**

2C21/RK33	\$ .24	2C34/RK34	\$ .22
1642	.24	RK59	1.69

**MAGNETRONS**

2121A	\$ 7.95	2148	\$12.75
2122	7.95	2154B	22.50
2126	6.95	5129	11.95
2127	12.75	5130	47.50
2131	8.49	714AY	3.59
2132	12.95	725A	6.45

**DUO-DIODE GAS RECTIFIERS**

3B22/ELIC	\$1.98	CK1005	\$ .09
4B24/EL3C	1.98	CK1006	.85

**SPECIALS**

4D22	\$9.95	1625 beam amp	\$ .19
4D32	9.95	1629 tuning eye	.19
28D7 beam amp	.29	1631 beam amp	.98
559 UHF diode	.98	1636 beam amp	.98
1624 beam amp	.67	REL21 spark gap	.98

1630 orbital beam hexode \$ .49  
RK60/1641 duodiode vac rect. .42

**RECEIVING TUBES**

0A2	\$1.29	6B8G	\$ .69	12AT7	\$ .79
0A4G	.89	6BA6	.55	12AU6	.57
0B2	1.67	6BE6	.52	12AU7	.67
0Z4	.57	6BF6	.57	12AV6	.54
O1A	.39	6BG6G	1.47	12BA6	.55
1A3	.44	6BH6	.59	12BE6	.49
1A4	1.09	6BJ6	.57	12C8	.34
1A4P	.97	6C4	.19	12F5GT	.58
1A5GT	.49	6C5	.47	12H8	.27
1A6	.79	6C6	.57	12J5GT	.34
1A7GT	.67	6C8G	.69	12J7GT	.67
1AB5	.59	6D6	.44	12K7GT	.52
1B3/8016	1.15	6D8G	.79	12K8	.59
1B4	1.19	6E5	.69	12L7	.49
1B5/25S	.89	6F5	.47	12SA7	.57
1C5GT	.59	6F6	.57	12SC7	.54
1C6	.89	6F8GT	.57	12SF5	.59
1C7G	.89	6F7	.69	12SF7	.54
1D5GP	.97	6F8G	.87	12SG7	.52
1D7G	.89	6G6G	.69	12SH7	.49
1D8GT	.95	6H6	.39	12SJ7	.47
1F4	.75	6H6GT	.37	12SK7	.57
1F5G	.75	6J5	.47	12SL7	.59
1G4GT	.69	6J5GT	.39	12SN7	.52
1G6GT	.65	6J6	.77	12SQ7	.49
1E7G	1.15	6J7	.67	12SR7	.69
1F4G	.55	6J7GT	.65	12T3	.49
1H6GT	.54	6K5GT	.79	14A4	.79
1H6GT	.87	6K6GT	.44	14A7	.52
1J6G	.75	6K7	.49	14B6	.69
1L4	.48	6K8	.79	14F7	.69
1LA4	.79	6L5GT	.79	14F8	.59
1LA6	.89	6L6	1.05	14H7	.79
1L7A	.89	6L6G	.99	14J7	.87
1LC5	.69	6L6GA	.85	14N7	.85
1LC6	.79	6L7	.79	14Q7	.67
1LD5	.79	6L7G	.87	14R7	.69
1LE3	.69	6N7	.75	19A	.49
1LE5	.79	6O7	.64	25L6GT	.53
1L7A	.79	6R7	.79	25Z5	.44
1LN5	.67	6S7G	.79	25Z5G	.43
1N5GT	.59	6S8GT	.77	25Z6GT	.43
1P5GT	.67	6SA7	.44	26	.49
1Q5GT	.67	6SC7	.59	27	.42
1R4	.59	6SD7GT	.49	28D7	.35
1R5	.49	6SF5	.49	30	.37
1S4	.59	6SF7	.59	31	.59
1S5	.49	6SG7	.59	32	.85
1T4	.53	6SH7	.37	32L7GT	.89
1T5GT	.69	6SJ7	.47	33	.69
1T7	.59	6SK7GT	.44	34	.37
1U4	.57	6SL7GT	.59	35/51	.57
2A3	.87	6SN6GT	.97	35A5	.63
2A4G	1.07	6SN7GT	.54	35B5	.55
2A5	.69	6S07	.45	35C5	.59
2A6	.79	6SR7GT	.52	35L6	.39
2A7	.79	6SS7	.44	35W4	.49
2V3G	.69	6ST7	.72	35Y4	.49
2X2	.37	6SU7GT	1.25	35Z3	.57
2X2A	.65	6SV7	.79	35Z4	.49
3A4	.34	6T7G	.89	35Z5	.39
3A5	.59	6T8G	.67	36	.67
3A8	1.79	6U8GT	.63	37	.35
3R7/1291	.29	6U7G	.49	38	.37
3D6/1299	.29	6V6	.89	39/44	.27
3LF4	.79	6V6GT	.57	41	.49
4-200A	.47	6W4	.63	42	.49
3C5GT	.67	6W7G	.74	43	.49
384	.57	6X4	.57	45	.52
3V4	.67	6X5GT	.47	45Z3	.57
5R4GY	1.09	6Y6G	.67	45Z5	.55
5T1	.87	6Z5G	.98	46	.62
5U4G	.49	6Z5G	.59	47	.69
5V4G	.87	7A/XXL	.59	49	.85
5W4	.67	7A6	.59	50	1.39
5X4G	.57	7A7	.53	50A5	.69
5Y3GT	.39	7AG7	.72	50B5	.53
5Y4G	.49	7B4	.53	50L6GT	.52
5Z3	.52	7B5	.67	50Y6	.57
5Z4	.77	7B6	.56	53	.87
6A3	.92	7B7	.59	56	.45
6A4LA	1.09	7C4	.34	57	.45
6A6	.79	7C5	.48	58	.49
6A7	.69	7C7	.59	59	.89
6A8	.75	7E5	.67	70L7	.99
6A9	.79	7E6	.54	71A	.59
6AC7	.74	7E7	.62	75	.53
6AD7G	1.09	7F7	.59	76	.44
6AP6G	.79	7H7	.59	77	.43
6AG5	.69	7K7	.87	78	.44
6AG7	.98	7L7	.69	80	.37
6A16	1.89	7N7	.67	81	1.25
6AJ5	.79	7Q7	.59	82	.84
6AK5	.85	7R7	.69	83	.75
6AK6	.79	7V7	.87	83V	.89
6AL5	.59	7W7	.79	84/6Z4	.56
6AR5	.49	7X7	.79	85	.69
6AR6	.59	7Y4	.47	89Y	.35
6AR5	.52	7Z4	.57	117L7/	
6AT6	.44	12A6	.57	M7	1.19
6AU6	.59	12A6	.17	117N7	1.19
6AV6	.47	12A7	.89	117P7	1.19
6BA6	.89	12ASGT	.49	117Z3	.49
6BG6	.79	12AR7GT	.80	117Z3	.49
6B7	.87	12AT6	.44	117Z6	.65

**RADIO HAM SHACK Inc.**  
189 GREENWICH STREET . NEW YORK, N. Y.

**PHONE DIGBY 9-0347**  
Prices Subject to Change  
Without Notice  
All Merchandise Guaranteed  
F.O.B. N.Y.C. Minimum  
Order \$10.00  
20% Deposit Required



# RHS Warehouse Clearance

Profit by these spectacular values! We're clearing our warehouse to make room for incoming stock! Everything goes!

# SALE!

### OIL CONDENSERS—DC RATINGS

3x.1	mfd	600v	\$.49	8	mfd	2000v	\$.95
.25	mfd	600v	.25	.1	mfd	2500v	1.09
.5	mfd	600v	.25	.25	mfd	2500v	1.19
1	mfd	600v	.28	.5	mfd	2500v	1.29
2	mfd	600v	.28	2	mfd	2500v	1.98
2x2	mfd	600v	.57	.01	mfd	3000v	1.07
4	mfd	600v	.57	.05	mfd	3000v	1.19
6	mfd	600v	.97	.1	mfd	3000v	1.39
8	mfd	600v	1.05	.25	mfd	3000v	1.49
10	mfd	600v	1.15	.5	mfd	3000v	1.69
3x.1	mfd	1000v	.59	1	mfd	3000v	2.19
.25	mfd	1000v	.29	2	mfd	3000v	3.47
.5	mfd	1000v	.39	4	mfd	3000v	4.45
1	mfd	1000v	.49	1	mfd	3600v	2.39
2	mfd	1000v	.69	.25	mfd	4000v	1.98
4	mfd	1000v	1.29	.5	mfd	4000v	2.49
8	mfd	1000v	1.89	1	mfd	4000v	2.79
10	mfd	1000v	2.07	2	mfd	4000v	3.10
20	mfd	1000v	3.29	3	mfd	4000v	4.95
.7	mfd	1500v	.77	.1	mfd	5000v	1.98
1	mfd	1500v	.97	.25	mfd	5000v	2.29
2	mfd	1500v	1.19	1	mfd	5000v	2.98
4	mfd	1500v	1.98	1	mfd	7000v	1.49
24	mfd	1500v	4.98	.01	mfd	7500v	1.79
1	mfd	2000v	.69	.02	mfd	7500v	1.79
.25	mfd	2000v	.89	.03	mfd	7500v	1.79
1	mfd	2000v	.97	.05	mfd	7500v	1.79
1	mfd	2000v	1.19	1	mfd	7500v	1.79
2	mfd	2000v	1.98	2x.1	mfd	7500v	4.95
4	mfd	2000v	3.89	.02	mfd	12000v	9.95

### HIGH CAPACITY CONDENSERS

2x3500	mfd	25v	\$3.47	100	mfd	50v	.45
2500	mfd	3v	.35	4000	mfd	18v	1.95
3000	mfd	25v	2.45	4000	mfd	30v	3.25
650	mfd	80v	1.29	2350	mfd	24v	2.25
1000	mfd	15v	.98	10000	mfd	25v	4.57
200	mfd	35v	\$.57				

- 1000KC crystal BT cut.....\$3.95
- 3" scope shield.....\$1.29
- 2 sp. dial dr. for 3/4" shaft ratios 5 to 1-1 to 1. .\$.49

### SELENIUM RECTIFIERS FULL WAVE BRIDGE TYPE

Input: 0-18v AC		Output: 0-14.5v DC	
Type #	Max. DC Current	Price	
18D1	1.2	\$3.59	
18E1	2.4	3.49	
18F1	6.4	4.95	
18K1	13.0	8.95	
18J1	17.5	11.95	
18K2	26.0	17.95	
18K3	39.0	24.95	
18K4	52.0	29.95	
18K5	65.0	35.95	

Input: 0-40v AC		Output: 0-34v DC	
Type #	Max. DC Current	Price	
40D1	0.6	\$2.95	
40E1	1.2	3.29	
40F1	3.2	7.99	
40K1	6.0	9.95	
40J1	9.0	12.95	
40K2	12.0	18.95	
40J2	18.0	22.45	
40K4	24.0	32.50	
40K5	30.0	37.95	
40J4	36.0	42.50	

Input: 0-120v AC		Output: 0-100v DC	
Type #	Max. DC Current	Price	
40D1	.6	\$7.85	
40E1	1.2	10.76	
40F1	3.2	16.65	
40K1	6.0	27.47	
40J1	9.0	34.35	

### SINGLE PHASE FULL WAVE—Center Tapped

Input: 10-0-10v AC		Output 8v DC	
Type #	Max. DC Current	Price	
20E1	1.2	\$1.89	
20F1	2.4	2.25	
20K1	6.4	3.87	
20J1	12.0	4.95	
20K2	16.0	7.95	
20K3	24.0	11.95	
20K4	36.0	14.95	
20K5	48.0	17.95	
20K6	60.0	22.49	
20K7	72.0	25.95	
20K8	84.0	27.95	
20K9	96.0	32.50	
20K10	120.0	36.50	

### THREE PHASE FULL WAVE—Bridge Rectifiers

Input: 120v AC		Output: 150v DC	
Type #	Max. DC Current	Price	
40D31	.9	\$16.52	
40E31	1.8	19.87	
40F31	4.75	27.95	
40K31	9.0	32.50	
40J31	12.0	54.99	

Current ratings can be increased 2 to 2 1/2 times by fan cooling

### TRANSFORMERS—115v 60 cyc

HS—Herm. Sealed		FS—Full Shell	
OF—Open Frame		FE—Fully Enclosed	
SECONDARIES			
HS	6350v @ .025 arms (16KV ins)	Wgt	Ht
OF	6250v or 8350v or 2600v @ .056 arms	37	12
HS	2500v @ 15 ma	13 1/2	5 1/2
FS	2700v @ 2 ma; 6.3v @ 6A; 2.5v @ 2A	3	3
HS	1600v @ 4 ma; 350-0-350v @ 150 ma; 6.3v @ 9A	9 1/2	5 1/2
HS	1540v @ 5 ma; 340-0-340v @ 300 ma	10	5 1/2
FS	1120-0-1120v @ 500 ma; 12v CT @ 14A; 2.5v @ 10A; 17v @ 2.5A; 32v @ 25 ma 115/230 pri.	45	7 1/2
HS	925v @ 10 ma; 525-0-525v @ 60 ma; 2x5v @ 3A; 6.3v CT @ 3.6A; 6.3v @ 2A;	14 1/2	5 1/2
FE	700-0-700v @ 300 ma	34	5 1/2
FE	500-0-500v @ 175 ma	16 1/2	5 1/2
FS	430-0-430v @ 340 ma; 6.3v CT @ 6.3A; 5v @ 6A	14	5 1/2
HS	425-0-425v @ 75 ma; 6.3v @ 1.5A; 5v @ 3A	8 1/2	5 1/2
FE	415-0-415v @ 60 ma; 5v CT @ 2A 115/230 dual pri	7 1/2	5 1/2
HS	405-0-405v @ 150 ma; 6.3v CT @ 2 1/2A; 5v @ 3A; 2.5v CT @ 5A	7 1/2	4 1/2
HS	400-315-0-100-315v @ 20 ma; 2x5.3v @ 9A; 5v @ 3A; 2.5v @ 2A	12 1/2	6 1/2
HS	500-385-0-385v @ 200 ma; 3x6.3v @ 6A; 5v @ 3A; 2.5v @ 2A	15	6 1/2
FE	325-0-325v @ 12 ma; 255-0-255v @ 240 ma	15 1/2	5 1/2
HS	300-0-300v @ 65 ma; 6.3v @ 2.5A; 6.3v @ 1A; 2x5v @ 2A	6 1/2	3 1/2
HS	120-0-120v @ 50 ma	3 1/2	4 1/2
HS	80-0-80v @ 225 ma; 5v @ 2A; 5v @ 4A	6 1/2	4 1/2
FE	0-17.4/21.6/25.2v @ 400 ma; 6.3v @ 5A; 2.6v CT @ 2.5A pri 115.230.	7	5 1/2
SECONDARIES			
OF	18 or 36v @ 15A	Wgt	Ht
FS	13.5v CT @ 3.25A	5 1/2	4 1/2
FE	12.6v CT @ 10A; 11v CT @ 6.5A	12 1/2	6 1/2
FS	3x10.3v CT @ 7A	17 1/2	4 1/2
HS	115v @ 1A; 6.3v @ 2A;	9 1/2	5 1/2
HS	6.4v @ 10A; 6.3v @ 6A;	7 1/2	5 1/2
OF	6.5v @ 8A; 6.5v @ 6A; 2.5v @ 1.75A	9 1/2	4 1/2
TRANSFORMERS—220v 60 CYC			
FE	512.5-0-512.5 @ 427 ma.	24 1/2	6 1/2
FE	3x5v @ 12A; 4v @ 25A	10	5 1/2
FE	3x6.3v CT @ 3A; 6.3v CT @ 1.6A	9 1/2	5 1/2
FE	10v CT @ 6.5A; 6.3v CT @ 2.5A; 6.3v CT @ 1.8A 220/440 pri.	13	5 1/2
FE	Step up/down 110/220 500 watt	25	6 1/2
FE	Step up/down 110/220/220/440 600 watt	39	5 1/2
FILTER CHOKES—HI V INS			
HS	600 hy @ 1 ma/5000 ohms	1	2 1/2
HS	325 hy @ 2 ma/4500 ohms	1	2 1/2
HS	200 hy @ 10 ma/5260 ohms	1 1/2	3 1/2
FE	30 hy @ 60 ma/240 ohms	6	4 1/2
HS	10 hy @ 25 ma/870 ohms	1	2 1/2
HS	15 hy @ 70 ma/500 ohms	1	2 1/2
FS	10 hy @ 200 ma/85 ohms	3 1/2	3 1/2
FS	3 30 hy @ 250 ma/70 ohms	6 1/2	4 1/2
FS	10/20 hy @ 85 ma/2000 ohms	2 1/2	3 1/2
FE	14/3.5 hy @ 40/400 ma	17	4 1/2
FE	3 hy @ 50 ma/300 ohms	1 1/2	1 1/2
FE	2 hy @ 175 ma/60 ohms	1 1/2	2 1/2
FE	5 hy @ 70 ma/100 ohms 2 dual	5	3 1/2
FE	hy @ 350 ma/6 ohms	12	6 1/2
HS	1 hy @ 5A	9	4 1/2
HS	.065 hy @ 2.5A	11	6 1/2
HS	.05 hy @ 15A	11	6 1/2

### COMPONENTS

50 mfd ceramic condensers.....	\$.29
50 mfd button condensers.....	.07
55 mfd ceramic feed thru.....	.08
4-30 mfd ceramic trimmers.....	.29
25. 50 mfd air trimmers screwdriver.....	.29
100, 140 mfd air trimmers screwdriver.....	.39
50 mfd 5KV GE vacuum condenser.....	1.49
1 mfd 600v donut condenser (152 in box)	per box 1.98
TMC-300 national variable 300 mfd.....	1.29
Single gang variable 33-435 mfd.....	.69
Five gang variable 11.5-30 mfd per section.....	.98
Three megacycle IF coil double slug.....	.29
Thirty megacycle IF coil.....	.19
80 meter osc. coil for ARC5.....	.29
80 meter PA final coil for ARC5.....	.29
0-1 MA meter Weston 506.....	2.95
-11.5 decibel meter Weston 301.....	9.95
2r. 6v. 12v vibrators.....	.98
Circuit breaker 15 amp.....	.98
J37 key.....	.69
200 watt power supply kit, complete.....	17.95
400 watt modulation xformer 803, 813, 100th.....	19.95
Output xformer UTC pri: 8500 ohms, sec: 0-8-125-500.....	.69
500 watt 12.5 ohm Rheostat.....	3.49
Driver unit WE 35 watt.....	4.95
Horn throat for above.....	.39
Rotary switch GE Mylex, 2 deck SP2T.....	.49
Plate caps ceramic, 2x2, 807, etc.....	.19
Plate caps ceramic, 866A, 813, etc.....	.19
Couplings ceramic 1/4" to 1/4".....	.29
Couplings ceramic 1/4" to 3/8".....	.29
Couplings ceramic 3/8" to 1/2".....	.29
Crystal socket ceramic 2 prong 5/32".....	.14

### SOCKETS

Angle octal.....	\$.19	Ceramic for 5D21.....	
Magnal.....	.59	705A.....	\$.89
Diheptal.....	.59	Ceramic for 832.....	
Safety recessed.....		828, 829.....	.69
for 2x2.....	.39	Mylex for VT127A.....	.59
Mylex for 813.....	.59	Ceramic acorn.....	.29
		Ceramic for 866A.....	.59

### EQUIPMENT

APN-1 altimeter transceiver.....	New	\$7.95
ATR inverter 12v DC in 110v AC 100w out.....	New	16.95
AN/CRW-2 UHF receiver.....	New	5.95
BC 1016 tape recorder.....	New	139.50
BC 950A-121 xmitter 100-150 mc modulated.....	New	49.50
BC 778 Gibson Grl.....	Shell worn	3.95
BC375E xmitter, 7 tuning units, dynamotor.....	Like New	69.50
BC-AL229 receiver.....	Used	2.95
BC 733 receiver.....	Used	6.95
RC 433 receiver.....	Used	24.95
RC 458 modulator.....	New	1.98
RC 434A control box/SCR269.....	Used	2.45
RC 996T1 interphone amplifier Like New.....	Used	6.95
RC 602A control box/SCH522.....	Used	.49
RC-22 relay for SCR269.....	New	2.95
RC-22 relay for SCR269.....	Used	1.95
CF1 Navy unit w/200 KC crystal.....	New	14.95
Constant Voltage transformer, sola 190/260-60c in 115v-1.7A out.....	New	16.95
DM19 dynamotor 12v DC in 200 ma cont out.....	Good	5.95
EF8 foundation unit.....	Good	4.95
KS12013 wire recorder GE, complete.....	Good	97.50
LM7 or 10 frequency meter.....	Good	37.50
MIN26C compass receiver.....	Good	24.95
M10 dynamic chest mike.....	New	4.95
PE94 dynamotor/SCR22.....	Good	1.98
P'E97A vibrator power supply.....	New	4.95
R89/ARN5 receiver.....	New	7.95
SCR515 altimeter, complete.....	New	29.95
T17B carbon mike.....	Good	.98
T21B field interphone radiosonde.....	Good	19.95
TU25 tuning unit/BC223.....	New	1.79

### PHONE DIGBY 9-0347

Write for quantity prices  
Prices subject to change without notice

# RADIO HAM SHACK Inc.

189 GREENWICH STREET, NEW YORK, N. Y.

**FULLY  
GUARANTEED**

**BRAND NEW SURPLUS OFFERED BY A LEADING**

**A.C. MOTORS**

5071930, Delco, 115 V., 60 Cycle, 7000 r.p.m. Price \$4.50 each net.

36938-2, Haydon Timing Motor, 110 V., 60 cycle, 2.2 w.; 4/5 r.p.m. Price \$3.00 ea. net.



Type 1600 Haydon Timing Motor—110 V., 60 cycle, 3.2 w., 4 r.p.m., with brake Price \$4.00 each net

Type 1600 Haydon Timing Motor—110 V., 60 cycle, 2.2 w., 1/240 r.p.m. Price \$3.00 each net.

Type 1600 Haydon Timing Motor 110 V., 60 cycle, 2.3 w., 1 r.p.m. Price \$2.70 each net.

Type 1600 Haydon Timing Motor, 110 V., 60 cycle, 2.2 w., 1 1/5 r.p.m. Price \$2.70 each net.

Type 1600 Haydon Timing Motor 110 V., 60 cycle, 3.5 w., 1 r.p.m. With shift unit for automatic engaging and disengaging of gears. Price \$3.30 ea. net.

Type 1600 Haydon Timing Motor, 110 V., 60 cycle, 2.2 w., 1/60 r.p.m. Price \$3.00 each net.

Eastern Air Devices Type J33 Synchronous Motor 115 V., 400 cycle, 3 phase, 8,000 r.p.m. Price \$8.50 each net.

Telechron Synchronous Motor, Type B3, 115 V., 60 cycle, 2 r.p.m., 4 w. Price \$5.00 each net.

Barber-Colman Control Motor, Type AYLC 5091, 24 volts D.C., .7 amps 1 R.P.M., Torque 500 in. lbs. Contains 2 adjustable limit switches with contacts for position indication. Ideal for use as a remote positioner or a beam or television antenna rotator, will operate on A.C. 60 cycle. Price \$6.50 each net.

**SERVO MOTORS**

CK 1, Pioneer, 2 phase, 400 cycle. Price \$10.00 each net.

CK 2, Pioneer, 2 phase, 400 cycle. Price \$4.25 each net.

10047-2-A Pioneer 2 phase, 400 cycle, with 40:1 reduction gear. Price \$7.25 each net.

FPE-49-6 Diehl, Low-Inertia, 115 V., 60 cycle, 2 phase, .3 amps., 10 watt, output. Price \$34.50 each net.

FPE-25-16 Diehl Low Inertia 20 V., 60 cycle, 2 phase, 1600 r.p.m., .85 amps. Price \$10.00 ea. net.

FP 25-3 Diehl, Low Inertia, 20 V., 60 cycle, 2 phase, .50 amps., 3200 r.p.m. Price \$10.00 each net.

CK2, Pioneer, 2 phase, 400 cycle, with 40:1 reduction gear. Price \$6.50 each net.

MINNEAPOLIS-HONEYWELL TYPE B Part No. G303AY, 115 V., 400 Cycle, 2 phase, built-in gear reduction, 50 lbs. in torque. Price \$8.50 each net.

**AMPLIFIER**

Pioneer Gyro Flux Gate Amplifier, Type 12076-1-A. Price \$17.50 ea. net, with tubes.

**REMOTE INDICATING  
MAGNESYN COMPASS SET**

Pioneer Type AN5730-2 Indicator and AN5730-3 Transmitter 26 V., 400 cycle. Price \$40.00 per set new sealed boxes.



Kollsman Remote Indicating Compass Set Transmitter part No. 679-01, indicator part No. 680k-03, 26 V., 400 cycle. Price \$12.50 each net.

**GYROS**

Schwein Free & Rate Gyro type 45600. Consists of two 28 V. D.C. constant speed gyros. Size 8" x 4.25" x 4.25". Price \$10.00 ea. net.



Schwein Free & Rate Gyro, type 46800. Same as above except later design. Price \$15.00 each net.



Sperry A5 Directional Gyro, Part No. 656029, 115 volts, 400 cycle, 3 phase. Price \$17.50 each net.

Sperry A5 Vertical Gyro, Part No. 644841, 115 V., 400 cycle, 3 phase. Price \$20.00 each net.

Sperry A5 Amplifier Rack Part No. 644890. Contains Weston Frequency Meter. 350 to 450 cycle and 400 cycle, 0 to 130 voltmeter. Price \$10.00 each net.

Sperry A5 Control Unit Part No. 644836. Price \$7.50 each net.

Sperry A5 Azimuth Follow-Up Amplifier Part No. 656030. With tube. Price \$5.50 each net.

Pioneer Type 12800-1-D Gyro Servo Unit. 115 V., 400 cycle, 3 phase. Price \$10.00 each net.

Norden Type M7 Vertical Gyro. 26 V., D.C. Price \$19.00 each net.

Allen Calculator, Type C1 Bank and Turn Indicator, Part No. 21500, 28 V. D.C. Contains 28 V. D.C. constant speed gyro. Price \$10.00 each net.

**D.C. MOTORS**



5069625, Delco Constant Speed, 27 V., 120 r.p.m. Built-in reduction gears and governor. Price \$3.90 each net. A-7155, Delco Constant Speed Shunt Motor, 27 V., 2.4 amps., 3600 r.p.m., 1/30 h.p. Built-in governor. Price \$6.25 each net.

C-28P-1A, John Oster Series Motor, 27 V., 0.7 amps., 7000 r.p.m., 1/100 h.p. Price \$3.75 each net.

Jaeger Watch Co. Type 44-K-2 Contactor Motor, Operates on 3 to 4.5 volts D.C. Makes one contact per second. Price \$2.00 each net.

General Electric Type 5BA10AJ52C, 27 V. D. C., 0.65 amps., 14 oz. in. torque, 145 r.p.m. Shunt Wound, 4 lead reversible. Price \$5.00 each net.

General Electric Type 5BA10AJ37C, 27 V. D. C., .5 amps., 8 oz., in. torque, 250 r.p.m. Shunt Wound, 4 leads reversible. Price \$6.50 each net.

D.C. ALNICO FIELD MOTORS

5067043 Delco 12 volts, 10,000 rpm. Price \$5.50 each net.

5069600, Delco, 27 V., 250 r.p.m. Price \$5.50 each net.

5069466, Delco, 27 V., 10,000 r.p.m. Price \$3.50 each net.



5069370, Delco, 27 V., 10,000 r.p.m. Price \$5.00 each net.

S. S. FD6-16, Diehl, 27 V., 10,000 r.p.m. Price \$4.00 each net.

S. S. FD6-18, Diehl, 27 V., 10,000 r.p.m. Price \$4.00 each net.

S. S. FD6-21, Diehl, 27 V., 10,000 r.p.m. Price \$4.00 each net.

Sampsel Time Control Inc. Alnico Field Motor, 27 V. D.C. Overall length 3 5/16" by 1 3/8". Shaft 5/8" long by 3/16", 10,000 r.p.m. Price \$4.50 each net.

GENERAL ELECTRIC D. C. SELSYNS

8TJ9-PDN Transmitter, 24 V. Price \$3.75 each net.

8DJ11-PCY Indicator, 24 V. Dial marked—10° to +65°. Price \$4.50 each net.

8DJ11-PCY Indicator, 24 V. Dial Marked 0 to 360°. Price \$7.50 each net.

RELAYS

Type B4 28 volts D.C., 200 amps. continuous duty. Electric Auto-Lite Co. Part no. WSN4001. Price \$2.50 each net.

Type B5B, 28 volts D.C., 50 amps., continuous duty Hart Mfg. Co. Part no. 692R6. Price \$1.85 each net.

Type B8, 28 volts D. C., 250 amps., intermittent duty Cutler-Hammer. Part no. 6041H139A Price \$2.50 each net.

**INSTRUMENT  
ASSOCIATES**

37 EAST BAYVIEW AVE., GREAT NECK, N. Y.  
Telephone IMperial 7-1147

Write for Catalog NE100

U. S. Export License-2140



**SUPPLIER OF ELECTRONIC & AIRCRAFT EQUIPMENT****IMMEDIATE  
DELIVERY****INVERTERS**

**Wincharger Corp.** Dynamotor Unit. PE-101-C. Input 13, V.D.C. or 26 V.D.C. D.C. AT, 12.6 or 6.3 amps. Output 400 V.D.C. AT. .135 amps., 800 V.D.C. AT. .02 amps., 9 V.A.C. 80 cycle at 1.12 amps.

Price \$10.00 each net.

**153F, Holtzer Cabot**, Input 24 V.D.C. Output 115 V., 400 cycle, 3 phase, 750 V.A. and 26 V., 400 cycle, 1 phase, 250 V.A. Voltage and frequency regulated also built in radio filter.

Price \$115.00 each net.

**149H, Holtzer Cabot**. Input 28 V. at 44 amps. Output 26 V. at 250 V.A., 400 cycle and 115 V. at 500 V.A. 400 cycle.

Price \$40.00 each net.

**149F, Holtzer Cabot**. Input 28 V. at 36 amps. Output 26 V. at 250 V.A., 400 cycle and 115 V. at 500 V.A., 400 cycle.

Price \$40.00 each net.

**12117, Pioneer**. Input 12 V.D.C. Output 26 V., 400 cycle, 6 V.A.

Price \$22.50 each net.

**12117-2 Pioneer**. Input 24 V.D.C. Output 26 V. 400 cycle, 6 V.A.

Price \$20.00 each net.

**12116-2-A Pioneer**. Input 24 volts D.C., 5 amps. Output 115 volts 400 cycle single phase 45 watts.

Price \$100 each net.

**5D21NJ3A General Electric**. Input 24 V.D.C. Output 115 V., 400 cycle at 485 V.A.

Price \$12.00 each net.

**PE218, Ballentine**. Input 28 V.D.C. at 90 amps. Output 115 V., 400 cycle at 1.5 K.V.A.

Price \$50.00 each net.

**METERS**

**Weston Frequency Meter**. Model 637, 350 to 450 cycles, 115 volts.

Price \$10.00 each net.

**Weston Voltmeter**. Model 833, 0 to 130 volts, 400 cycle.

Price \$4.00 each net.

**Weston Voltmeter**. Model 606, Type 204 P, 0 to 30 volts D. C.

Price \$4.25 each net.

**Weston Ammeter**. Model 506, Type S-61209, 20-0-100 amps. D. C.

Price \$7.50 each net with ext. shunt.

**Weston Ammeter**. Type F1, Dwg. No. 116465, 0 to 150 amps. D. C.

Price \$6.00 each net.

With ext. shunt \$9.00 each net.

**Westinghouse Ammeter**. Type 1090-D120, 120-0-120 amps. D. C.

Price \$4.50 each net.

**Weston Model 545**. Type 82PE Indicator. Calibrated 0 to 3000 RPM. 2 3/4" size. Has built-in rectifier, 270° meter movement.

Price \$15.00 each net.

**VIBRATOR**

**Rauland Corp.** vibrator non-synchros type Stock No. 3H6694-11; 6, 12 or 24 V.D.C., Input. Frequency 200 cycle.

\$3.50 each net.

**Sperry Phase Adapter**. Part No. 661102.

Used for operating three-phase equipment from a single phase source. 115 volts 400 cycle. Maximum load 50 watts.

Price \$15.00 each net.

**PIONEER AUTOSYNS**

**AY1**, 26 V., 400 cycle.

Price \$5.50 each net.

**AY14D**, 26 V., 400 cycle, new with calibration curve.

Price \$15.00 each net.

**AY20**, 26 V., 400 cycle.

Price \$7.50 each net.



**AY31**, 26 V., 400 cycle. Shaft extends from both ends.

Price \$10.00 ea. net.

**AY38**, 26 V., 400 cycle. Shaft extends from both ends.

Price \$10.00 each net.

**PRECISION AUTOSYNS**

**AY101D**, new with calibration curve.



PRICE—WRITE OR CALL FOR SPECIAL QUANTITY PRICES

**AY131D**, new with calibration curve.

Price \$35.00 each net.

**AY130D**, new.

Price \$35.00 each net.

**PIONEER AUTOSYN****POSITION INDICATORS**

**Type 5907-17**. Dial graduated 0 to 360°, 26 V., 400 cycle.

Price \$15.50 each net.

**Type 6007-39**, Dual, Dial graduated 0 to 360°, 26 V., 400 cycle.

Price \$30.00 each net.

**PIONEER TORQUE UNIT**

**Type 12602-1-A**.

Price \$40.00

each net.



**Type 12606-1-A**. Price \$40.00 each net.

**Type 12627-1-A**. Price \$80.00 each net.

**MAGNETIC AMPLIFIER ASSEMBLY**

**Pioneer Magnetic Amplifier Assembly** Saturable Reactor type output transformer. Designed to supply one phase of 400 cycle servo motor.

Price \$8.50 each net.

**PIONEER TORQUE UNIT AMPLIFIER**

**Type 12073-1-A**, 5 tube amplifier, Magnesyn input, 115 V., 400 cycle.

Price \$17.50 each net with tubes.

ALL PRICES,  
F. O. B.  
GREAT NECK,  
N. Y.

**BLOWER ASSEMBLY  
MX-215/APG**

**John Oster**, 28 V.D.C., 7000 r.p.m. 1/100 h.p.

Price \$4.50 each net.

**Westinghouse** Type FL Blower, 115 V. 400 cycle, 6700 r.p.m., Airflow 17 C.F.M.

Price \$3.70 each net.

**RATE GENERATORS**

**PM2, Electric Indicator Co.**, .0175 V. per r.p.m.

Price \$8.25 each net.

**F16, Electric Indicator Co.**, two-phase, 22 V. per phase at 1800 r.p.m.

Price \$12.00 each net.

**J36A, Eastern Air Devices**, .02 V. per r.p.m.

Price \$9.00 each net.

**B-68, Electric Indicator Co.**, Rotation Indicator, 110 V., 60 cycle, 1 phase.

Price \$14.00 each net.

**Weston Tachometer Generator** (aircraft type) model 752-J4 single phase. A.C. output.

Price \$17.50 each net.

**SINE-COSINE GENERATORS**

(Resolvers)

**FPE 43-1, Diehl**, 115 V., 400 cycle.

Price \$20.00 each net.

**SYNCHROS**

**1F Special Repeater**, 115 V., 400 cycle. Will operate on 60 cycle at reduced voltage.



Price \$15.00 each net.

**7G Generator**, 115 V., 60 cycle.

Price \$30.00 each net.

**2J1F3 Selsyn Generator** 115 volts, 400 cycle.

Price \$5.50 each net.

**2J1M1 Control Transformer** 105/63 V., 60 cycle.

Price \$20.00 each net.

**2J1G1 Control Transformer**, 57.5/57.5 V., 400 cycle.

Price \$1.90 each net.

**2J1H1 Selsyn Differential Generator**, 57.5/57.5 V., 400 cycle.

Price \$3.25 each net.

**W. E. KS-5950-L2**, Size 5 Generator, 115 V., 400 cycle.

Price \$4.50 each net.

**5G Generator** 115 volts, 60 cycle.

Price \$50.00 each net.

**5G Special Generator** 115/90 V., 400 cycle.

Price \$15.50 each net.

**5SF Repeater**, 115/90 V., 400 cycle.

Price \$19.00 each net.

**2J1F1 Selsyn Generator**, 115 V., 400 cycle.

Price \$3.50 each net.

**5SDG Differential Generator** 90/90 V., 400 cycle.

Price \$12.00 each net.

**1CT Control Transformer**. 90/55 volts, 60 cycle.

Price \$40.00 each net.

**POSITION TRANSMITTER**

**Pioneer Type 4550-2-A** Position Transmitter, 26 volts 400 cycle, gear ratio 2:1.

Price \$15.00 each net.

**INSTRUMENT  
ASSOCIATES**

37 EAST BAYVIEW AVE., GREAT NECK, N. Y.  
Telephone IMperial 7-1147

Write for Catalog NE100

Western Union address:  
WUX Great Neck, N. Y.

# VOLUME CONTROLS

A QUARTER MILLION IN STOCK! ALL BRAND NEW!  
 STANDARD BRANDS and GUARANTEED BY WELLS  
**ORDER YOUR REQUIREMENTS TODAY!**

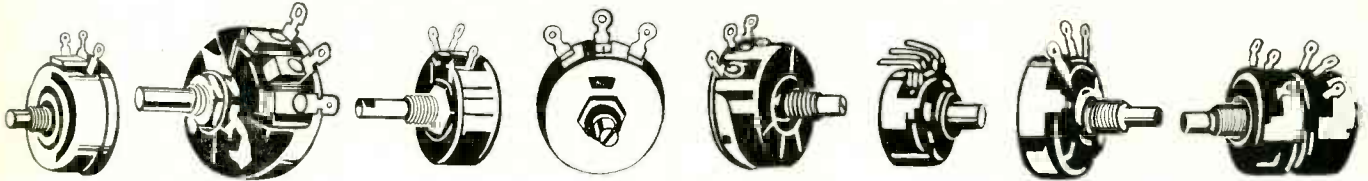

AB — Allen-Bradley  
 SP — Stackpole  
 CLA — Clarostat  
 CTS — Chicago Telephone Supply  
 LIN — Linear  
 AUD — Audio  
 RHE — Rheostat  
 S — With Switch

IRC — International Resistor Co.  
 CRL — Central Radio Labs  
 MY — Mallory  
 GIB — Gibbs Microkat  
 CA — Carban  
 WW — Wire wound  
 OB — Open Back  
 M — Midget

WIR — Wirt  
 DeJ — DeJur  
 UTA — Utah  
 WE — Western Electric  
 SD — Screw Driver Slot  
 \* — Knurled Shaft  
 Lx — Lock-Type Bushing

STOCK NO.	OHMS	MFR.	SHAFT LENGTH	TAPER	TYPE	WATT	UNIT PRICE	STOCK NO.	OHMS	MFR.	SHAFT LENGTH	TAPER	TYPE	WATT	UNIT PRICE	STOCK NO.	OHMS	MFR.	SHAFT LENGTH	TAPER	TYPE	WATT	UNIT PRICE
360-1	3	MY	1 1/8	RHE.	WW	4	\$0.27	360-140	1K	CTS	1 1/2	LIN.	WW	5	\$0.29	360-496	10K	UTA	2 1/2	LIN.	WW	3	\$0.35
360-202	5	IRC	1 1/2 SD	LIN.	WW	1 1/2	.23	360-457	1K	CTS	1 1/2	LIN.	WW	5	.29	360-486	10K	WIR	SD	LIN.	WW	3	.30
360-401	6	IRC	1 1/2	RHE.	WW	6	.32	360-27	1K	CTS	1 1/2 SD	LIN.	WW	5	.27	360-150	15K	CTS	SD	LIN.	CA	2	.24
360-281	10	MY	1 1/2	RHE.	WW	4	.27	360-138	1K	CTS	1 1/2 SD	LIN.	WW	5	.27	360-427	15K	CTS	SD	LIN.	WW	3	.30
360-2	10	MY	1 1/2 SD	LIN.	WW	4	.25	360-481	1K	IRC	1 1/2	AUD.	CA	1 1/2	.34	360-472	15K	CTS	SD	LIN.	WW	3	.30
360-386	15	MY	1 1/2	RHE.	WW	4	.27	360-212	1K	IRC	2 1/2	LIN.	WW	3	.23	360-223	15K	UTA	SD	LIN.	WW	3	.30
360-510	20	UTA	SD	LIN.	WW	—	.20	360-500	1K	MY	1 1/2 SD	LIN.	WW	4	.27	360-460	20K	CLA	3/4 SD	LIN.	CA	2	.26
360-518	50	CTS	1 1/2 SD	LIN.	WW	5	.29	360-313	1K	MY	3/4 knob	LIN.	WW	4	.30	360-187	20K	CRL	SD-M	LIN.	CA	1 1/2	.24
360-415	75	CTS	1 1/2 Flat	RHE.	WW	3	.25	360-377	1K	UTA	1 1/2	LIN.	CA	2	.24	360-342	20K	CRL	LIN.	LIN.	WW	3	.32
360-3	75	CTS	2 1/2	LIN.	WW	5	.29	360-22	1.2K	CTS	1 1/2	LIN.	CA	1	.24	360-305	20K	CTS	2 1/2	LIN.	CA	1 1/2	.26
360-192	75	CLA	1/8	LIN.	WW	3	.25	360-458	1.5K	CRL	3/8 SD	LIN.	WW	3	.23	360-224	20K	CTS	SD	AUD.	CA	2	.26
360-74	100	CLA	SD	LIN.	WW	2	.23	360-131	1.5K	CTS	SD	LIN.	WW	3	.23	360-119	20K	CTS	1 1/2	LIN.	WW	3	.32
360-76	100	CRL	2 1/2	LIN.	WW	3	.25	360-456	1.5K	CTS	1 1/2	LIN.	WW	3	.29	360-97	20K	CTS	3/4 SD	LIN.	WW	3	.32
360-84	100	CTS	SD	LIN.	WW	3	.23	360-203	1.5K	CTS	1 1/2	LIN.	WW	3	.29	360-166	20K	CTS	3/4	LIN.	WW	3	.32
360-80	100	CTS	SD	LIN.	WW	5	.27	360-28	1.5K	CTS	SD	LIN.	WW	5	.30	360-154	20K	CTS	SD	LIN.	WW	3	.30
360-6	100	CTS	SD	LIN.	WW	5	.27	360-372	2K	CRL	1 1/2	LIN.	CA	1 1/2	.22	360-340	20K	DeJ	3/8	LIN.	WW	6	.85
360-454	100	CTS	1 1/2	LIN.	WW	5	.29	360-14	2K	CTS	1 1/2 SD	LIN.	CA	2	.22	360-319	20K	GIB	3/8	LIN.	WW	5.50	
360-88	100	CTS	SD	LIN.	WW	5	.29	360-30	2K	CTS	SD	LIN.	WW	3	.27	360-278	20K	GIB	1 1/2	LIN.	WW	5.50	
360-193	100	IRC	1 1/2	LIN.	CA	1 1/2	.22	360-405	2K	CTS	SD	LIN.	WW	3	.27	360-277	20K	GIB	1 1/2	LIN.	WW	5.50	
360-515	100	IRC	1 1/2	LIN.	WW	6	.32	360-284	2K	CTS	1 1/2	LIN.	WW	3	.30	360-354	20K	SP	2 1/2 H	LIN.	CA	2	.28
360-384	150	CLA	1 1/2 S	LIN.	WW	4	.40	360-295	2K	WIR	1 1/2 mil	LIN.	WW	3	.30	360-50	20K	SP	3/8	LIN.	CA	3	.32
360-141	150	CTS	1 1/2	LIN.	CA	1	.22	360-105	2K	IRC	SD	LIN.	WW	3	.27	360-452	25K	CLA	3/8 SD	AUD.	WW	3	.30
360-492	150	IRC	SD	LIN.	WW	3	.23	360-459	2K	IRC	SD	LIN.	WW	3	.35	360-328	25K	CLA	3/8 SD	LIN.	WW	3	.30
360-390	200	CRL	SD	LIN.	WW	3	.23	360-116	2.5K	CRL	SD-M	RHE.	CA	1 1/2	.22	360-235	25K	CLA	3/8 mil	LIN.	WW	3	.32
360-391	200	CTS	1 1/2	RHE.	WW	3	.25	360-307	2.5K	CTS	2 1/2	LIN.	CA	1	.24	360-65	25K	CTS	SD	LIN.	CA	1	.30
360-487	200	CTS	1 1/2	LIN.	CA	1	.22	360-107	2.5K	CTS	SD	LIN.	CA	1	.22	360-353	25K	CTS	SD	LIN.	CA	2	.32
360-145	200	CTS	1 1/2 SD	LIN.	WW	5	.27	360-441	2.5K	CTS	1 1/2	LOG.	CA	2	.22	360-127	25K	CTS	1 1/2 SD	LIN.	CA	2	.34
360-502	200	CTS	1 1/2	LIN.	WW	5	.29	360-462	2.5K	CTS	1 1/2 mil	LIN.	WW	3	.29	360-499	25K	CTS	1 1/2	LIN.	CA	2	.32
360-473	200	CTS	2 1/2	LIN.	WW	5	.29	360-108	2.5K	CTS	SD	LIN.	WW	3	.27	360-336	25K	IRC	1 1/2	LIN.	CA	1 1/2	.30
360-89	200	CTS	SD	LIN.	WW	5	.27	360-468	3K	CLA	3/8 SD	LIN.	WW	3	.27	360-332	25K	MY	SD	LIN.	WW	4	.36
360-522	200	IRC	1 1/2 mil	LIN.	WW	3	.25	360-31	3K	CTS	SD	LIN.	CA	2	.22	360-226	25K	SP	2 1/2 H	LIN.	CA	2	.36
360-397	200	MY	1 1/2	LIN.	WW	4	.27	360-411	3K	CTS	1 1/2 SD	LIN.	CA	2	.24	360-329	25K	WIR	1 1/2	LIN.	WW	4	.38
360-527	250	CTS	1 1/2 SD	LIN.	WW	3	.23	360-297	3K	CTS	3/8 SD	LIN.	WW	3	.29	360-283	25K	MY	SD	LIN.	CA	2	.32
360-521	250	UTA	1 1/2 SD	LIN.	WW	3	.23	360-130	3K	CTS	SD	LIN.	WW	5	.30	360-290	30K	CLA	3/8	LIN.	WW	3	.36
360-10	255	CTS	3/8 SD	LIN.	WW	5	.27	360-77	3K	CTS	2 1/2	LIN.	WW	5	.34	360-403	30K	IRC	SD	LIN.	CA	1 1/2	.32
360-91	300	CTS	SD	LIN.	WW	5	.29	360-453	3K	MY	1 1/2	LIN.	CA	2	.24	360-156	40K	CTS	SD	LIN.	CA	1	.32
360-524	300	MY	SD	LIN.	WW	4	.27	360-210	3K	MY	SD	LIN.	WW	4	.29	360-265	40K	CTS	2 1/2 H	LIN.	CA	1	.34
360-291	500	CLA	1 1/2	LIN.	WW	3	.25	360-371	3K	MY	3/8	LIN.	WW	4	.30	360-51	50K	CTS	SD	AUD.	CA	1	.34
360-387	500	CLA	1	LIN.	CA	1	.22	360-451	3K	MY	3/8 SD	LIN.	WW	4	.29	360-517	50K	WIR	1 1/2	LIN.	WW	4	.38
360-512	500	CRL	1 1/2	LIN.	WW	3	.25	360-400	3K	MY	3/8	LOG.	WW	—	.30	360-261	50K	SP	3/8	AUD.	CA	1	.34
360-99	500	CTS	SD	LIN.	WW	3	.23	360-240	3.5K	CRL	1 1/2 SD	RHE.	CA	2	.24	360-237	50K	WIR	SD	LIN.	WW	4	.36
360-58	500	CTS	2 1/2	LIN.	WW	3	.25	360-180	4K	CRL	1 1/2	LIN.	CA	1	.24	360-470	50K	WIR	5 1/2 Flex	LIN.	WW	4	.40
360-422	500	CTS	SD	AUD.	WW	3	.25	360-416	4K	SP	1 1/2 mil	LIN.	CA	3	.31	360-200	70K	MY	3/8 SD	LIN.	WW	4	.38
360-101	500	CTS	SD	LIN.	WW	5	.27	360-34	5K	CLA	1 1/2	LIN.	WW	3	.29	360-327	70K	WIR	1 1/2	LIN.	WW	4	.38
360-477	500	CTS	1 1/2 SD	LIN.	WW	5	.27	360-117	5K	CRL	SD-M	RHE.	CA	1 1/2	.30	360-52	75K	CLA	2	LIN.	CA	2	.36
360-19	500	CTS	1 1/2 SD	LIN.	WW	5	.27	360-125	5K	CRL	1 1/2	LIN.	CA	1 1/2	.25	360-236	75K	SP	SD	LIN.	CA	2	.34
360-379	500	CTS	1 1/2	LIN.	WW	5	.29	360-90	5K	CTS	SD	AUD.	CA	1	.25	360-529	100K	CRL	SD	LIN.	CA	1 1/2	.32
360-139	500	CTS	1 1/2 SD	LIN.	WW	5	.27	360-514	5K	CTS	SD	LIN.	CA	2	.25	360-518	100K	CTS	SD	LIN.	CA	1	.36
360-92	500	CTS	1 1/2 SD	LIN.	WW	5	.27	360-303	5K	CTS	SD	RHE.	CA	2	.25	360-64	100K	IRC	2 1/2 H	LIN.	CA	2	.34
360-478	500	CLA	1	LIN.	CA	2	.27	360-494	5K	IRC	3/8	LIN.	WW	3	.30	360-54	100K	SP	SD-M	LIN.	CA	1 1/2	.45
360-476	500	CLA	1 1/2	LIN.	WW	3	.24	360-288	5K	MY	1 1/2 SD	LIN.	CA	2	.27	360-322	100K	WIR	1 1/2 SD	LIN.	WW	4	.36
360-523	500	MY	1 1/2 SD	LIN.	WW	4	.25	360-485	5K	MY	1 1/2 SD	LIN.	WW	4	.32	360-282	150K	CRL	1 1/2 mil	RHE.	CA	1	.36
360-7	600	CRL	1 1/2	AUD.	WW	3	.25	360-357	5K	SP	3/8	LIN.	WW	3	.30	360-56	150K	CTS	3/8	RHE.	CA	2	.36
360-614	600	CRL	1 1/2	LIN.	CA	3	.22	360-20	6K	SP	3/8	LIN.	CA	3	.32	360-66	150K	CTS	2 1/2 H	LIN.	CA	2	.36
360-21	600	IRC	SD	LIN.	WW	1 1/2	.25	360-298	7K	IRG	1	LIN.	WW	3	.34	360-205	150K	CTS	SD	LIN.	CA	2	.34
360-196	750	CRL	1 1/2	LIN.	WW	3	.20	360-220	7.5K	UTA	1 1/2	LIN.	Open Back*	.25	360-206	150K	IRC	SD	LIN.	CA	2	.34	
360-102	750	CTS	1 1/2 SD	LIN.	WW	3	.23	360-396	10K	CLA	3/8	LIN.	WW	4	.38	360-530	150K	IRC	SD	AUD.	CA	2	.34
360-374	750	UTA	1 1/2	LIN.	CA	2	.22	360-43	10K	CLA	SD	LIN.	WW	3	.30	360-287	200K	CTS	2 1/2 SD	LIN.	CA	2	.36
360-111	950	CLA	1 1/2 SD	LIN.	WW	3	.23	360-185	10K	CRL	1 1/2	LIN.	CA	1 1/2	.28	360-516	200K	SP	LIN.	LIN.	CA	3	.38
360-11	1K	CLA	1 1/2	LIN.	WW	3	.25	360-304	10K	CTS	1 1/2	LIN.	CA	1 1/2	.28	360-483	250K	SP	1 1/2	AUD.	CA	2	.36
360-455	1K	CRL	1 1/2	LIN.	WW	3	.25	360-258	10K	CTS	3/4	RHE.	CA	2	.30	360-441	1M	CRL	SD	LIN.	CA	1 1/2	.40
360-474	1K	CTS	1 1/2 SD	LIN.	WW	3	.23	360-363	10K	CTS	3/8 mil	AUD.	CA	2	.30	360-438	1M	CTS	SD	LIN.	CA	2	.40
360-26	1K	CTS	1 1/2	LIN.	WW	3	.25	360-362	10K	CTS	SD	AUD.	CA	2	.30	360-484	1M	IRC	3/8	AUD.	CA	1 1/2	.42
360-475	1K	CTS	1 1/2	L																			



**NOTE PRICE DROP ON MANY ITEMS**

**PEAK ELECTRONICS CO.**  
188 Washington St., New York 7, N. Y.

**GUARANTEED SURPLUS**



**ALLEN BRADLEY SOLENOID**

115 Volt 60 Cycle Coil D.P.S.T. 25 Amp Contacts. \$3.75 ea. 3 for \$9.90



**Heavy Duty Tap Switch Ohmite Model 412**

Single Pole 6 Positions, Non-Shorting 50 amp. contacts. Vitreous Enamel case. List \$16.00. Only \$2.95

Mallory Vibropack Kit. 6 Volt Input. Output 300 Volts at 100 MA. Transformer & Vibrator. \$5.95 for both



**PANEL METERS**

Brand New Govt Surplus

2"	WESTON 0-1 Ma DC 26 ohms res.	\$3.50
2"	G.E. 0-1 Ma DC (volt scale)	2.95
2"	G.E. 0-5 Ma DC (amp scale)	1.95
2"	G.E. 0-30 Volts DC 1000 ohm/v.	2.50
2"	G.E. 0-30 Amps DC	2.45
2"	G.E. 0-1 Amp RF (Internal Thermo)	2.45
2"	WESTINGHOUSE 0-2 Ma DC	3.95
2"	WESTERN ELECTRIC 0-80 Ma DC	2.95
2"	G.E. 0-200 Ma DC	2.95
2"	TRIPLETT 75 Amps AC	2.95
2"	WESTINGHOUSE 0-20 Ma DC	3.95
2"	TRIPLETT 0-300 VAC	2.95
2"	WESTON 8-200 Micro Amp. Mod 301	8.75
2"	SIMPSON 0-1 Ma	3.95
2"	WESTERN ELECTRIC 0-200 microamp.	12.95
2"	WESTERN ELECTRIC 0-200 microamp.	9.95
2"	GE 0-4 amps RF	1.95
2"	GE 0-50 MA DC	2.45
2"	GE 0-250 MA AC	3.95
2"	BEDE 0-200 Microamp.	3.95
2"	SIMPSON 0-2 Amps RF (Square)	2.45
2"	SIMPSON 0-5 Ma (Square)	1.95
2"	SUN 0-50 Ma (Square)	1.95
2"	SUN 0-25 Ma (Volt Scale)	1.95
2"	GE 0-50 Ma	1.95
2"	WESTON 0-20 Volts DC	2.50
2"	SUN 0-20 Volts DC	1.75
2"	SIMPSON 0-20 Ma (Amp Scale)	1.75
2"	WESTINGHOUSE 0-10 Ma	1.95

**SCOPE TRANSFORMERS**

Pri 110V 60CY—Hermetically Sealed  
2500 V @ 12MA ..... \$2.95  
1050V @ 20MA, 20V 4.5A, 2.5V 5A ..... 4.75

**SCOPE AND FIL. TRANSFORMER**

Pri. 115 volts, 60 cycles. Sec. 4400 volts RMS 4.5 MA., 5 volts CT 3 amps. Fil. Ins. 15 KV RMS test. Hermetically sealed. Has insulated plate cap for rectifier. Made by Raytheon. 4 1/2 x 5 x 5 1/2" Only \$4.95 5 for \$22.50



**HIGH CURRENT MICAS**

Type G4 Ceramic Case 5 3/4" High, 5" Diameter Tolerance 5% or Better.

CAP MFD	Amps 1 Mc	Amps 300 Kc	KV DC	Price Each
.08	60	42	4	\$27.50
.1	70	50	4	29.50
.15	60	42	4	24.50
.037	45	35	6	26.50
.02	40	30	9	29.50
.02	55	38	10	29.50
.0117	40	27	14	24.50
.0075	39	27	15	24.50
.009	40	25	15	29.50
.00978	40	25	15	29.50
.01	43	28	15	29.50
.0025	23	15	20	29.50
.00315	26	18	20	29.50
.001	30	20	22	33.50
.0033	25	16	25	35.50
.00082	14	8	30	27.50

**TYPE G3 4" HIGH 5" DIAMETER**

.0013	15	9	15	14.50
-------	----	---	----	-------

**TYPE G2 3" HIGH 3 1/2" DIAMETER**

.00057	8	4	10	6.95
--------	---	---	----	------

**1/2" High 2-1/16 DIAMETER**

.004	16	11	6	4.95
.00024	4	2	6	3.95

Tremendous stocks on hand. Please send requests for quotas. Special quantity discounts. Price f.o.b. N. Y. 20% with order unless rated, balance C. O. D. Minimum order \$5.00.

**APRIL SPECIALS**

50 K 1% W. W. Resistors, Precision	\$ .14
.07 MFD 1000 VDC Type C Mica	.39
.35 at 16 KV plus .75 at 8 KV	3.95
.1 MFD 7500 VDC Oil Cond.	.89
.05 MFD 7500 VDC Oil Cond.	.75
7MFD 330 VAC Oil Cond.	.69
Meter Multiplier 2 MEG. 1/2 of 1% 2KV	1.49

**MISCELLANEOUS BARGAINS**

.02 400 volt dc tubulars	15 for .99
2mfd 250 volts ac oil cond.	6 for .99
10 meg 10 watt resistor	2 for .99
Heineman 25 amp 110 volt ac ckt breaker	1.19
Ceramicon .0006 mfd	20 for .99
.01 800 volt dc pigtail micas	10 for .99
.001 600 volt dc pigtail micas	5 for .99
.006 600 volt, pigtail micas	12 for .99
Butterfly cond. 2 to 11 mmf ball brngs	3 for .99
CD type 4 micas .001 600vdc	10 for .99
25 mmf variable cond. (mc250s)	.59
10,600 ohm potentiometers	6 for .99
5 meg potentiometer	5 for .99
Trimm "Commercial" Headphones	5 for .99
1G mfd 450 volt electrolytic (EB9160)	3 for .99
Cond. 150 mmf .07 spacing	2 for .99
Variable ceramicon 20 to 125mmf type 823	5 for .99
Western Electric silver variable 5 to 2.5 mmf	8 for .99
G.E. weatherproof switch DPDT 20amp 120vac	.99 ea.

**OIL CONDENSERS**

1 mfd 600 vdc	29	8 mfd 2000 vdc	5.95
2 mfd 600 vdc	39	10 mfd 2000 vdc	6.95
4 mfd 600 vdc	59	2 mfd 4000 vdc	4.95
6 mfd 600 vdc	79	1 mfd 5000 vdc	4.50
3/3 mfd 600 vdc	79	1/1 mfd 7000 vdc	2.25
10 mfd 600 vdc	89	1 mfd 7500 vdc	9.25
4 mfd 1000 vdc	95	.02, .01 mfd 12kv	
5 mfd 1000 vdc	1.89	dc	5.75
2 mfd 1500 vdc	1.25	.005/.01 mfd 12 kv	
4 mfd 1500 vdc	2.25	dc	5.50
6 mfd 1500 vdc	2.95	65 mfd 12,500 vdc	12.95
1 mfd 2000 vdc	1.45	2 mfd 18 kv dc	49.55
2 mfd 2000 vdc	2.25	1 mfd 15 kv dc	15.95

**SILVER MICA CAPACITORS**

MMF: 10, 47, 50, 60, 240, 750, 1000... .09 ea.

**HIGH VOLTAGE VACUUM CONDENSER**

50 MMF 32KV EIMAC VC 50-32. 5.75



**MOSSMAN SWITCHES**

4 Pole Single Throw \$1.10  
3 PDT. plus 6 PST. 1.75



50 megohm 35 watt Resistor with mount. \$1.49 each; 10 for \$9.90

**30 WATT WIRE WOUND RESISTORS**

Ohms: 100-150-2000-2500-3k-4k-4500-5k-5300.  
10k-15k-18k ..... 15 ea. 8 for .99

**ADJUSTABLE RESISTORS**

20 Watt: 1, 5, 50 Ohms	.25
50 Watt: 80, 100, 500 Ohms	.35
75 Watt: 40, 80, 100, 150, 200 Ohms	.39
100 Watt: 20, 50, 75, 120, 180 Ohms	.49
150 Watt: 50, 100 Ohms	.59

**WIRE WOUND RESISTORS**

5 Watt type AA, 20-25-50-200-470-2500-4000 ohms	\$ .09 ea.
10 watt type AB, 25-10-84-400-470-1325-1000-2000-4000 ohms	.15 ea.
20 watt type DG, 50-70-100-150-300-750-1000-1500-2500-2700-5000-7500-10000-16000-20000-30000 ohms	.20 ea.

**MIDGET VARIABLE CONDENSERS**

Steatite Insulation

15 MMF (HF 15)	.39
Dial 15 MMF (HF 15 D)	.69
250 MMF (MC 250 S)	.69
325 MMF	.79

**U. H. F. COAX. CONNECTORS**

UG12U-UG14U-UG21U ..... .29

Precision 15 Meg. 1% Accuracy Resistor, Non-inductive, 1 watt, hermetically sealed in glass 25 ea. 10 for \$1.90

Thermal Time Delay Relay. 15 to 3 seconds, plugs into 4 prong Tube Socket Glass Enclosed 250 V... .75

**PRECISION 1% W.W. RESISTORS**

Ohms: 2K, 2500, 5K, 8500, 95K, 750K..... .25 ea.



**FILAMENT TRANSFORMER**

6.3 volts at 12 amps. Primary 110 volts 60 cy. Size 3 1/4"H x 2 7/8"W x 3"D. WT 3 1/2 lbs. As Illustrated. While they last ..... \$1.69 ea.



**SENSITIVE RELAY**

Breaks at 3 MA. Beautifully Constructed and delicately pivoted. Approx. 2000 ohms resistance. Housed in dustproof aluminum can. Plugs into 5 prong socket. Only ..... \$1.49 ea.

**PLUG IN CAPACITOR**

8 x 8 Mfd 600 volts DC. Oil filled. Plugs into standard 4 prong socket, 3 3/4 x 3 1/2 w x 1 7/8 d. .... \$1.39

GENERAL ELECTRIC Type PBC Instantaneous Overcurrent Relay. Adjustable from 100 to 200 MA. Electrical and Manual Reset, 4 PDT. Reset 110 Volts 60 Cycles ..... \$7.95

General Electric Overload Relay. Electrical Reset 110 Volts 60 Cycle



Breaks at 640 Milliamps but easily adjustable for other currents. Terminate values at only ..... \$2.95

10 for 25.00



**MINIATURE HEADPHONES**

250 ohms imp. Can be used for sound power Telephones, etc. Type HS 30 ..... .69 ea.  
10 For ..... 5.99  
Hi Imp Transf. for above... .45

GENERAL PURPOSE TRANSFORMERS  
Ideal for Bias, Filament, Isolation, Stepdown, etc. 2 isolated 110V Pri. Sec. 110V at 900 ma plus 6.3 @ 2 amps. Fully cased ..... Now \$1.49 ea.



**ADVANCE D.P.D.T.**

**ANTENNA RELAY**

110 V. 60 cycle coil Steatite Insulation. Only \$1.95 each.

**W. W. POWER RHEOSTATS**

150 Ohms 50 Watt	.59
250 Ohms 50 Watt	.59
300 Ohms 50 Watt	.59
Dual 200 Ohms 50 Watt	.79
100 ohm 100 watt	.99
200 ohm 100 watt	.99

**CERAMICONS**

MMF: 1.5, 2, 3, 8, 10, 20, 22, 120, 500..... .05 ea.

**BAKELITE CASED MICA**



MMF	VDC	Price	MMF	VDC	Price
D .001	600	\$ .18	C .001	3 KV	.90
E .01	600	.26	C .002	3 KV	.95
D .02	600	.26	D .005	3 KV	1.20
E .027	600	.26	C .005	3 KV	1.24
C .01	1 KV	.45	C .006	3 KV	1.50
C .056	1 KV	.50	D .002	3 KV	.70
C .07	1 KV	.55	C .001	5 KV	.70
C .02	1200	.35	C .0005	5 KV	.85
C .024	1500	.65	C .0015	5 KV	1.60
C .023	1500	.75	C .003	5 KV	1.90
C .015	2 KV	.80	C .005	5 KV	2.50
C .02	2 KV	.90	C .002	6 KV	2.90
D .002	2500	.45	B .007	5 KV	2.75
E .005	2500	.55	B .0005	8 KV	2.90
C .025	2500	1.25	B .0012	8 KV	3.25

**FILAMENT TRANSFORMERS**

110 V 60 CY Pri. Cased.	
5 Volt 15 Amp	\$2.75
2.5 Volt 10 Amp	3.49
2.5 Volt CT 21 Amps	4.75
5 1/2 V CT 21A, 7.5V 6A, 7.5V 6A	4.95
5 Volt 4A, 6.3V, 3A	2.45
2.5V CT 20A, 2.5V CT 20A.	6.95

**CHOKE BARGAINS**

6 Henry 50 ma 300 ohms	3 for \$0.99
6 Henry 80 ma 220 ohms	2 for .99
8 Henry 160 ma 140 ohms	.99
1.5 Henry 250 ma 72 ohms	.99
Swing 1.6/12 Henry 1 Amp/100 ma 15 ohms	15.95



**HEAVY DUTY RHEOSTAT**

25 Ohms, 675 Watts Max. with Knob and Hardware ..... \$3.95  
10 for \$29.50

**PEAK ELECTRONICS CO.**  
188 Washington St., New York 7, N. Y.

Phone GO 7-6486  
GO 7-6443  
DEPARTMENT EA

**LINE VOLTAGE STABILIZERS**

**RAYTHEON**—Navy Type, CRP-301407 Input: 92-138V, 57/63 CPS., 1 PH. Output: 115V, 0.82 KVA., 1% Reg., 0.96 PF. Weight 385 lbs. Overall size—36" high x 20" wide x 12 1/4" deep. Enclosed in Navy Grey Ventilated Cabinet for Wall Mounting.

Brand New ..... \$69.50



**RAYTHEON** Adj. input taps 95-130V., 60 cy., 1 Ph. Output: 115V., 60 Watts. 1/2% of 1% Reg. Wt. 20 lbs. 6 1/2" H x 8 1/4" L x 4 1/2" W. Overload protected. Sturdily constructed. Tropicalized. Special..... \$12.50

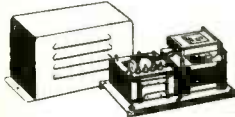

**TRANSFORMERS 1.5 KVA Stepdown**

General Electric Cat. No. 76G173. Input: 115 or 230 Volts, 60 cycles. Output: 23 or 11.5 volts at 1.5KVA. Either high voltage connection may be used with either low voltage connection. Weight 50 lbs. Brand new ..... \$23.95

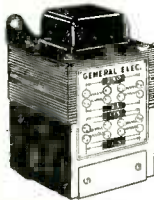

**FILAMENT TRANSFORMER**

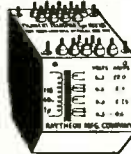

Raytheon Hypersil core. Primary: 115V., 60 cycles. Sec: 6.3 at 22A., 6.3 @ 2.4A., 6.3 @ 2.25A., 6.3 at 0.6A., 1700V. INS. Brand New ..... \$3.95

**For type 866 tubes**

Kenyon. Input: 115 volts. Output: 2.5 volts center tapped, at 10 amps. Glazed porcelain standoff insulated for high voltage breakdown.

Brand New \$2.95



**AUTO TRANSFORMER**  
G.E. 400 cy. Cat. No. 80G184 K.V.A. .945S—520P Volts 460/345/230/115 New..... \$3.45

**FILAMENT TRANS. 400/2600 cy.**

Input: 0/75/80/85/105/115/125V. Output: 5V3A, 5V3A, 5V3A, 5V3A, 5V6A, 5V6A, 6.3V6A, 6.3V5A \$1.95

**THYRATRON POWER TRANS.**

Raytheon UX8876, 400/1600 cy. PBI: 115V, 1 PH SEC: 50-050V at 0.5A, 6.3V 1.2A Test r.m.s. 1780 \$2.75

**PULSE TRANSFORMER**

Utah No. 9350 ..... \$1.25



**BLOCKING OSC. TRANS.**

Westinghouse =132 AWP Fosterized \$4.95

**12 and 24 Volt POWER KIT**

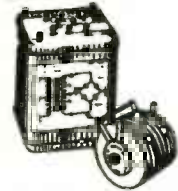

Consists of Power Trans. and full wave bridge selenium rectifier. Input: 115/230 A.C. Output: 12/24V D.C. at 1.1 amps. Fine for operating relays, small motors, dynamometers, or for low voltage D.C. source in laboratories, etc.

Brand New \$7.95

**SWEEP GENERATOR CAPACITOR**

High speed ball bearings. Split stator silver plated coaxial type. 5/10 mmfd. Brand new. \$1.00

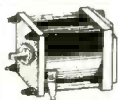

**Differential Synchros**



90/90 volts, 400 cycles. Brand new in sealed containers. Ford Inst. Co. type 5SDG. Brand new. \$12.50

**MICROWAVE RECEIVERS APR. 1, APR-4, APR-5A.**

Tuning Units for APR-1 or APR-4. TN-16 (38-95 mc.), TN-17 (74-320 mc.) TN-18 (300-1000mc.) These front ends may be used with any 30 mc. IF amplifier or as converters into receivers tuned to 30 mc.)

**MODEL AN/APA-10 PANORAMIC ADAPTER**

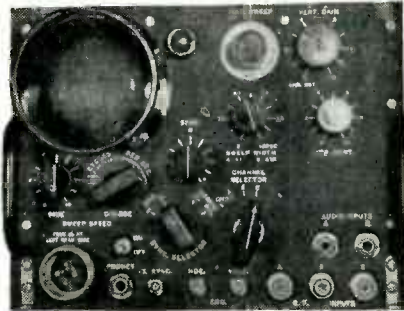

Provides 4 Types of Presentation:

- (1) Panoramic (2) Aural
- (3) Oscillographic (4) Oscilloscopic

Designed for use with receiving equipment AN/ARR-7, AN/ARR-5, AN/APR-4, SCR-587 or any receiver with I.F. of 455kc. 5.2mc. or 30mc. With 21 tubes including 3" scope tube. Converted for operation on 115 V. 60 cycle source. Includes 80 page T. M. .... \$195.00



**RADIO MODULATOR**

Type BC-423-B, or tweeter, is a miniature keying unit, modulator and transmitter combined. A dipole mounted atop the tweeter case radiates a signal pulse at 205 megacycles modulated by pulses occurring at 4,088 CPS. Uses 2-6J7, 1-6F6, 1-955, 1-5W4 tubes. Operates from 115V. 60 cy. source. Brand new including tubes and instruction book.. \$19.50

**PARABOLOIDS**

Spun Magnesium dishes 1 7/8" dia., 4" deep. Mounting brackets for elevation and azimuth control on rear. 1 1/2" x 1 1/2" opening in center for di-pole. Brand new per pair..... \$8.75

**MOTOR GENERATORS**

Allis-Chalmers 115V. D.C. to 120V, 60 cy. 1 Ph. 1.25 K.V.A., P.F. .80 Centrifugal starter. Fully enclosed.

New ..... \$97.50

Same as above but for 230V. D.C. \$125.00

input

Spare Parts Kit for either machine.....\$15.00

Diehl 120V. D.C. to 120V. A.C., 60 cy., 1 Ph., 2.5 K.V.A., P.F. .4. Complete with magnetic controller, 2 field rheostats and full set of spare parts including spare armatures for generator and motor.

New ..... \$185.00

O'Keefe and Merritt, 115V. D.C. to 120V. A.C. 50 cycles, 2 K. V. A., P.F. .9 Idles as a 3 phase synchronous motor on 208V. 60 cy.

New ..... \$165.00

Electrolux dynamotor 105/130V. D. C. at 6 amps. to 26 or 13V. D.C. at 20 amps or 40 amps. respectively. Fully filtered for radio use and complete with Square "D" lineswitch. Navy type CAJO-211444.

New ..... \$74.50

Shown above are selections from our inventory. A complete listing is now available. Write for it today.

**MERCURY CONTACT VACUUM RELAYS WE Type D-168479**

Glass sealed, mercury-wetted contact switches surrounded by operating coils encased in metal housings on octal tube base. S.P.D.T. contacts, 2 coils, 700 and 3300 ohms. Operating current coils seriesed 6.6 MA releasing at 5.2MA. Operating life 1000 hrs. at 60 operations per sec. Used for: High speed keying • tabulating • sorting and computing machines • Relay amplifiers • Vibrator supplies • Servo Mechanisms, etc.



\$4.75 ea. Brand New

Send for 4 page data sheet

**THERMOSTATIC TIME DELAY RELAY**

Amperite type 115 No.—45 Heater voltage 115V. Normally open SPST contacts. 45 sec. delay. Contact rating 115V-3A., A.C. (or 440V., A.C. 2A) max. voltage on contacts—1000 max voltage bet. contacts and heater 1500. Size 3 9/32 x 1 1/4" overall. Made for U. S. Navy..... \$1.10



**CRYSTAL DIODE**

Sylvania 1N21B. Individually boxed and packed in leaded foil. Brand new ..... \$1.00



**High Voltage Copocitors OIL Filled**

- .25 MFD., 20KV..... \$15.75
- .5 MFD., 25KV..... \$23.50
- 1 MFD., 15KV..... \$16.50
- 1MFD., 7.5KV..... \$4.95

All brand new. Made by prominent manufacturers.



**LAVOIE FREQ. METER MICRO-WAVE**

375 to 725 MCS

Model TS-127/U is a compact, self-contained, precision (± 1 MC) frequency meter which provides quick, accurate readings. Requires a standard 1.5V "A" and 45V "B" battery. Has 0-15 minute time switch. Contains sturdily constructed HI-"Q" resonator with average "Q" of 3000 working directly into detector tube. Uses 957, LS6 and 3S4 Tubes. Complete, new with inst. book, probe and spare kit of tubes. Less batteries. \$49.50

Write for descriptive circular..... \$49.50

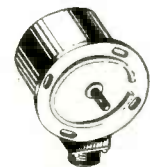

**LINEAR SAWTOOTH POTENTIOMETER No. KS 15138**

Has continuous resistance winding to which 24 volts D.C. is fed to two fixed taps 180° apart. Two rotating brushes 180° apart take off linear sawtooth wave voltage at output. Size approximately 3 1/2" dia. x 3" deep x 4 1/4" long. Enclosed in die cast alum. frame with AN connector socket.

\$5.50 Brand New

**U. S. NAVY SOUND POWERED BATTLE PHONES**

Western Electric No. D173312, Type O, Combination headset and chest microphone as illustrated. Brand new including 20 ft. of rubber covered cable ..... \$17.50

Automatic Elec. Co. No. GL843A0. Similar to above but including Throat microphone in addition to chest microphone. Brand new with 20 ft. rubber covered cable. \$13.50



**SYNCHRO GENERATORS**

Brand new—Gov't. sealed and inspected—Packed in overseas cans. Synchro Transmitters 115V., 60 cy. operation. Precision accuracy made for gun fire control. Cost Gov't. \$90.00 each. Wgt. 5 lbs. Dimensions: 4 1/2" L x 3 1/4". Brand New \$14.75 Per Pair

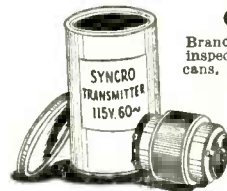

All prices indicated are F O B Tuckahoe, New York. Shipments will be made via Railway Express unless other instructions issued.

**ELECTRONICRAFT**

INC.

5 WAVERLY PLACE TUCKAHOE 7, N. Y. PHONE: TUCKAHOE 3-0044

All merchandise guaranteed. Immediate delivery, subject to prior sale.

All Prices Subject to Change Without Notice



**IMMEDIATE DELIVERY • LOW PRICES • FULLY GUARANTEED**

**AC-SERVO MOTORS**

**Pioneer Type CK-2.**  
26 v. 400 cycles fixed phase, var. phase 49 v. max. 40:1 gear reduction. Stock #SA-97A. Price \$6.50 each. Also available less gear train. Price \$4.25 each. Stock #SA-97.

**PIONEER CK-17**

400 cycle 2 phase. 26 v. fixed phase. 45 v. max. variable phase. Built in gear reduction. Output shaft speed approx. 4 rpm. Stock #SA-287. Price \$12.50

**KOLLSMAN 776-01**

400 cycle. 2 Phase drag cup type. Fixed phase 29 v., variable phase 35 v. max. 5840 rpm. 0.471 in./oz. stall torque. Spline shaft. Stock #SA-56. Price \$12.50 each. Available with 20:1 gear reduction. Stock #SA-56A. Price \$14.50 each

**FORD INST SERVO MOTOR**

115 volt 60 cycle two phase low inertia motor. 15 watts output. BuOrd. 207927. Stock #SA-291. Price \$49.50 each.

**MINNEAPOLIS-HONEYWELL Type G303AY2CA4**

115 v. 400 cycles. Built in gear reduction. 50 in./lb. torque. Stock #SA-268. Price \$6.75 each.

**BROWN TELEPLOTTER RECEIVER**

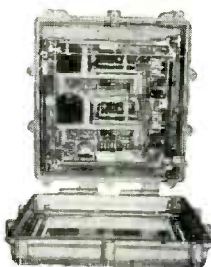

Price \$375.00

Model  
**791X1R**  
115 volt  
60 cycles

Contains a pen driven by two balancing motors which writes on rear of a translucent chart. Pen arm position is in terms of two co-ordinates supplied balancing motors thru two amplifiers. Originally intended for recording plotted or written data from central plotting board. Writes at one half scale on 18 in. chart. Discriminator input circuit designed to operate unit as function of two varying R.F. frequencies varying about mean of approx. 430 KC. Further data on request. (Shipping weight 435 lbs.)

Prices F.O.B. Paterson  
Phone ARMory 4-3366  
Teletype PAT. 199

WRITE FOR LISTING

**SERVO AMPLIFIER**



Minneapolis Honeywell 115 v. 400 cycle unit. For use with SA-268. Model G403ATCA3. Designed for use with A-C error signal from bridge circuit. Stock #SA-269A. Price \$8.50.

**DC SERVO MOTORS**

**C-1 Autopilot Servo Unit**—28 v. d-c Shunt motor. 2250 rpm. 2 magnetic clutches, reduction gear, differential and 2 magnetic brakes. Output shaft 15 rpm. Torque 225 in./lbs. Stock #SA-180 Price \$19.50 each



**John Oster A-21E-12R** — Split field series reversible motor. W.E. KS-5996-LO-4. 28 v. d-c at 0.4 amps. 2 watts output. 1 1/2" diam. x 2 1/2" lg. Ideal for relay or thyatron servos. Stock #SA-282. Price \$6.75 each



**G.E. 5PS56HC18** — Split field series reversible motor. 60 v. d-c at 1.4 amperes. 5500 rpm. 3" diam. x 5" lg. Ideal for servo applications. Stock #SA-273. Price \$8.75 each.

**SPERRY D.C. SERVO-MOTOR**



Part No. 8001058. Made for Sperry by Emerson Electric Mfg. Co. 3 1/4" lg. x 1 7/8" diam. Built in noise filter. Stock #SA-289. Price \$8.75 each.

**MAGNETIC AMPLIFIER ASSEMBLY**

Sperry 661824. Saturable reactor type output transformer. Designed to supply one phase of 400 cycle servo motor. Stock #SA-266. Price \$6.75 each

**PIONEER TORQUE UNITS**

Types:  
12602-1-A  
12604-3-A  
12606-1-A  
12627-1-A, 12627-7-A.



Prices On Request



**Blower Assembly MX-215/APG**

John Oster C-2P-1L 28 V. DC. 7000 RPM. 1/100 H.P. #2 L-R Blower.

Stock #SA-202. Price \$4.75 each

**400 CYCLE MOTORS**

**E.A.D. J-33.** 115V 3 phase. Synchronous 8000 rpm. 2" x 3". Stock #SA-59. Price \$6.50 ea.

**E.A.D. J-72B.** 115V 2 phase induction motor. 4700 rpm. Stock #SA-140. Price \$9.75 each.

**Westinghouse Blower.** Type FL. 6700 rpm. Capacitor type motor. 17 C.F.M. blower. Outlet 3/4" x 1 1/8". Includes capacitor. Stock #SA-144. Price 2.95 ea.

**SELSYN SPECIALS**



W.E. KS-5950-L2 Size 5. 115 v. 400 cycles. Use on reduced 60 cycles. Stock #SA-182. Price \$6.75 each



Type XXI 115 V. 60 cycle repeater. 2 1/2" diam. x 2 1/2" lg. Use as transmitter or repeater. Stock #SA-42. Price \$4.75 each

**ISF SYNCHRO SPECIAL**

Navy Ordnance Type 1F Special. Designed for 115 volt 400 cycles operation. Use as either generator or repeater. May be used on 24-28 volts 60 cycles operation. Stock #SA-29. Price \$19.50 each.

**SYNCHROS**

**Navy Types**

1G, 1F, 1CT, 5G, 5F, 5CT, 5DG, 5HCT, 5SF, 5HSF, 5SDG, 6DG, 6G, 6DG, 7G, etc.



Prices on Request

**D.C. MOTORS**

**Universal Electric DC**

W.E. KS-5603-1-02. 28 v. d-c 0.6 amps. 1/100 hp. 4 lead shunt. Stock #SA-233. Price \$2.95 ea. plus 15¢ p.p.



**12 V.D.C. Motor**

John Oster B-9-2 1.4 amps. 5600 rpm.

1 1/4" Diam. x 3 3/4" Lg. Spline shaft. C. W. rotation. Stock #SA-46. Price \$1.95 each.



**DELCO CONSTANT SPEED MOTOR A-7155**

1/30 hp. 27.5 v d-c 3600 rpm. Cont. duty. 2 1/2" diam. x 5 1/2" lg. 7/8" shaft extension, 5/32" diam. 4 hole base mounting. Stock #SA-94. Price 4.75.



**Delco 506925 Constant Speed DC Motor.** 27 v. d-c 120 rpm. Governor controlled. Stock #SA-249. Price \$3.95 each.

**General Electric 2 RPM Motor.** Type 5BA10FJ228. 27 v. d-c @ 0.6 amps. 10 lb/in torque at 2 rpm. Shunt wound. D-C noise filter. Stock #SA-274. Price \$6.75 each.

**Synchron 10 RPM Timing Motor**—24 V. Hanson Mfg. Co. Stock #SA-110. Price \$3.75 each.

**General Electric Type 5BA10AJ52C** 145 rpm. 27.5 volt D-C motor. 0.65 amps. 14 in./oz. torque. Shunt wound four lead reversible. Stock #SA-218. Price \$4.75 each.

**D-C ALNICO FIELD MOTORS**

Delco 5069156. 27.5 volts, 10,000 rpm. 1" x 1" x 2" lg. Stock #SA-236. Price \$6.75 each. Other models also available.

**Servo-Tek products co.**  
4 Godwin Ave. Paterson, N. J.

**SPECIALISTS IN FRACTIONAL HORSE POWER MOTOR SPEED CONTROL**



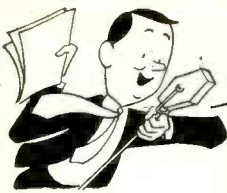

# ORDER from ARROW!

Receiver Easily Converted for Use in Citizens Band  
Crystal Controlled Local Oscillator. Broad Band Pass—  
20.7 MC IF's. Complete with 7-6AJ5, 1-12SR7, 2-12SN7,  
1-28D7, relays, crystals. Schematic furnished. New \$7.95  
Like new \$5.95 Less tubes \$3.95

### HERMETICALLY SEALED CHOKES

10 H. 100 M.A. 59¢ 3.7 H. 145 M.A. 59¢  
59 H. 100 M.A. 95¢ 10 H. 20 M.A. 39¢  
.5x.5x1x1 H.—4 winding layer wound .5H at  
3.56 A 140 ohms, 1H at 1.56 A 320 ohms. New 49¢

### TEN TUBE SUPERHET RECEIVER

with crystal controlled local oscillator. Has provisions  
for six crystal channels between 108 to 112 MCPS com-  
plete with tubes and crystals but less dynamotor.  
NEW \$7.95 Less Tubes and  
Like NEW \$5.95 dynamotor but NEW \$3.95

### WESTINGHOUSE AUXILIARY RELAY TYPE MC

Style x 423396 C—110 V 60 cycle 4 pole.  
Enclosed in glass. New \$7.50

### TUBES

Drastically Reduced from 10 to 50%  
Nationally Advertised Brands

Type	Net Price	Type	Net Price	Type	Net Price
1A4P.	\$0.24	6SF5GT.	.34	39/44.	.24
1A6.	.19	6S7G.	.39	49.	.39
1B5/25S.	.24	6S8GT.	.59	50.	.39
1B22.	1.49	6S7.	.59	57.	.24
1B26.	.39	6SJ7.	.69	70.	.24
1B29.	.39	6T7.	.39	77.	.24
1B32-532A	2.29	6U7G.	.29	211/Vt4L.	.29
1C6.	.19	6U7G.	.29	310A.	.34
1C7G.	.19	6Z7G.	.39	310A.	.34
1D5GP.	.24	6ZY5G.	.39	374B.	.39
1D7G.	.19	7C4/1203A	.24	700A.	7.95
1F4.	.24	7E5/1201.	.39	703A.	1.49
1F5G.	.24	10YVT25A	.19	705A.	.79
1H4G.	.24	12A6.	.34	714AY.	5.95
1J6G.	.24	12A6GT.	.34	724B.	4.95
1J6GT.	.24	12A7.	.34	801A.	.39
1P5GT.	.24	12A8GT.	.19	813.	5.95
1V.	.24	12F5GT.	.29	829.	6.95
2A6.	.39	12H6.	.29	832.	4.95
2A7.	.39	12J5GT.	.24	837.	1.49
2C26A.	.19	12J7GT.	.24	841.	.29
2V3G.	.49	12K8GT.	.24	864.	.29
2X2/879.	.24	12O7GT.	.24	872A.	.98
3F7.	.98	12SF5.	.24	954.	.19
4A10.	.98	12SF5GT.	.24	955.	.34
5BP4.	2.95	12SF7.	.24	957.	.19
5CP1.	2.95	12SH7.	.24	958.	.19
5D21.	9.95	12SR7.	.24	1626.	.24
5FP7.	.95	12SR7GT.	.29	1629.	.24
5J23.	5.95	12SN7GT.	.89	1630.	.29
5T4.	.49	12Z3.	.29	1636.	2.95
5W4.	.49	15R.	.19	1638.	.69
5Z4.	.49	19.	.59	1642.	.29
6AB7.	.89	2J22.	.24	2050.	.89
6AJ5.	.89	28D7.	.34	2051.	.49
6B8.	.59	30SPEC.	.7193.	.19	
6C4.	.29	(Vt67).	.59	9002.	.39
6D8G.	.59	30.	.24	9003.	.39
6F5GT.	.39	304T.	1.29	9008.	.29
6F6G.	.59	32L7GT.	.39	GL4A21.	.29
6H6.	.29	33.	.24	Amperite	
6J7GT.	.39	34.	.24	10T1.	.29
6K6G.	.59	35/51.	.24	Jan CRP72.	.98
6L5G.	.39	36.	.24	WE 331A.	.89
6L7G.	.39	37.	.24	REL36.	.69
6R7.	.34	38.	.24	VR 150.	.39
				VR 105.	.69

WRITE FOR QUANTITY PRICES

### MIKES—HEADSETS

HS-23 Hi Imp.	New	\$2.95
HS-33 Lo Imp.	New	2.95
HS-30 Hi Imp.	New	1.50
	Used	.79
T-17D Carbon Mike	New	2.75
T-24 Hi Imp. Carbon Mike	New	1.19
T-30 Throat Mike	New	.98
T-45 (or Navy) Lip Mike	New	.98
CD-307 Extension Cord for Headsets	New	.50

### CONDENSERS

	Each	
2 mfd. 4000 VDC Oil-Filled	\$2.95	
2 mfd. 5000 VDC Oil-Filled	4 for 10.00	3.95
1 mfd. 6000 VDC Oil-Filled	3 for 10.00	9.98
.25 mfd. 15000 VDC Oil-Filled		4.95
.00025 mfd. 25000 VDC Oil-Filled		2.95
.4 mfd. 1500 VDC Oil-Filled		.29
2 mfd. 600 VDC Oil-Filled	10 for 2.49	3.9
1 mfd. 600 VDC Oil-Filled	3 for 1.00	.24
1 mfd. 600 VDC Oil-Filled	5 for 1.00	.59
.1x.1x.1—1200 VDC Oil-Filled	2 for 1.00	1.19
50 mmfd.—5KV—5 Amp Vacuum Cond		1.19

### Miscellaneous SPECIALS

	Used	New
1D 6/APN 4 Scope, Excellent.	\$29.50	
R 7/APS 2 Receiver-Indicator		79.50
R 78/APS-15 Receiver-Indicator	34.50	
BC 1287 A Scope	75.00	
SCR 522 Transceiver 100 to 150 MC	12.95	
BC 1206 Receiver, 200 to 400 KC	34.95	75.00
MN 26 C or Y Receiver	3.95	5.95
RA 10 DA Receiver	17.50	24.95
T 26/APT 2 Transmitter	17.50	24.95
RT 7/APN 1 Transceiver	8.95	
APN 1 Complete	5.95	9.95
BD 71 6 Pos. Switchboard	24.50	
EE 8 Field Phones	9.95	12.95
BC 347 Interphone Amplifier	7.95	
1-70 Tuning Meter		2.95
AM 61 Indicator Amplifier		9.50
SCR 625 Mine Detector		39.50
PE 237 Power Supply		12.95
BC 461 Vee-Root Counter		.59
BC 442 Less Condenser	1.49	1.95
BC 306 Antenna TU for BC 375		1.50
A 27 Phantom Antenna		.98
APS 13 UHF Antenna, Pair		1.00
Manual for BC 312 & 342 J		2.50
Manual for SCR 269 G		2.95
FL 8 Filter		4.95
1-97 Bias Meter		3.95
RM 29 Remote Tel. Control		7.95
BC 602 Control Box		.98
One Tube Interphone Amplifier—Small compact aluminum case fully enclosed. 2 1/2" x 3 3/4" x 5 3/4". Less Tube		\$0.79
BC 717 Transmitter. New but less tubes		24.50
96Q1 Complete Autotune assembly with motor and frame as used in ARC-1 Transmitter. New		35.00
BC 709 Battery operated lightweight interphone amplifier. Complete with tube and shock mount, but less battery. New		3.95
SCR 183 Complete. New		49.50
Motor—Universal Electric—24 VDC—will also operate on 24 VAC. Diameter 1 1/2". Length 2 9/16". Shaft 1/8" x 1/4". New		1.49
BC 639 Receiver with RA 42 Rectifier		
RTA 1B Transceiver		
TA 2J24 Transmitter and MP 10G Power Pack		
SCR 269 Compass Installation		
R 5/ARN 7 Compass Installation		
MN 26 Compass Installation		
I. L. S. Installation (R 89-BC 733)		
SCR 584 Components		
R-132/TPS 10 Radar Receiver		
MD-22-URA /T1 Radar Modulator		
AN/APR1 Receiver and Tuning Units		
ASB7 Complete Radar Installation		
TS-251 Test Set		
BC221 Freq. Meter		

Information and prices on request

### BC-605 INTERPHONE AMPLIFIER

Easily converted to an ideal intercommunication set for office—home—or factory. Original—New \$4.95  
Like New \$3.95  
(With schematic)



All necessary parts and instructions to convert the above to AC operation with one remote station. \$8.25 additional.

### BC-604 TRANSMITTER FM 20-28 MC

11 and 15 meters. Can be operated on 10 meters—10 channel push button crystal. With all tubes and meter but less dynamotor. Excellent Condition \$12.95  
Crystals—Set of 80. 14.95  
BC 603—Companion receiver to above with tubes but less dynamotor. Used \$17.50

Model 15  
Ground radar training unit complete. 115 V. 60 C.P.S. operated. Consists of 515 MC transmitter; power supply; and pulse generator. Trains operator to detect land, air or sea targets and can be adapted to various receiver-indicator sets operating at 515 Mc. New, with instruction manual \$225.00

### BEAM INDICATORS

I 82-5"	New	\$4.95
Transmitter Selsyn for above		2.45
	both for	\$7.00
I 81-3"	New	3.45
Transmitter Selsyn for above		2.45
	both for	5.25
I 81	Used	2.45

### T-85/APT5 UHF TRANSMITTER

Operating over a frequency range of 300 to 1400 MCPC with a nominal output of from 10 to 30 watts. Unit is equipped with 110 V 60 CPS filament transformer; blower; lecher wire test frequency set, and 8 tubes—1-931 A; 2-6AC7; 2-6AG7; 1-6L6G; 2-829B; 1-3C22 (GL522) (oscillator). New in original box with Operating Instruction Manual. \$69.50

Send for free 8-page, illustrated

### Bulletin #103

listing many EXCEPTIONAL VALUES

## ARROW SALES, Inc.

Dept. ES

712-14 S. Michigan Ave., Chicago 16, Ill.

PHONE: HARRISON 7-9374

### DYNAMOTORS

DM-28—For BC-343 with Mount and Filter	New	\$6.95
	Used	3.95
DY-12—For ART-13 less filter and base	New	6.95
DM-36	Used	.95
	New	1.95
BD-77	New	5.95
PE-206	New	6.95
	Used	2.75
PE-101	New	2.75
PE-73	New	3.95
DM-53	New	3.95
	Used .95 (3 for \$2.00)	
DM-32	New	1.95
	Used .95 (3 for \$2.00)	

### BC 620

Receiver-Transmitter—2 crystal channels—20 to 27.8 MC FM—13 tubes. Metered, Plate and Filament. New \$14.95  
Used 9.95  
PE 97 Power Supply for above 6-12 volt vibrator type. Used—complete \$6.95  
Used less tubes, vib. & cond. 2.95  
FT 250 Mount for both BC 620 and PE 97 New \$1.50

### BC 223

Brand new Transmitter with all three tuning units, two tuning unit cases, spare tube carrying case, shock mount and brace; but less tubes at new low price of \$19.95  
Set of 5 tubes. \$3.95  
Tuning units are available separately at \$2.50  
Cases at \$1.95  
PE-125—12-volt Vibrator Pack. New \$12.95  
Used 8.95  
Spare parts kit for PE 125 containing 2 tubes; 2 vibrators and 13 fuses in metal container with handle and clasp (BX 41). New \$2.95

### COMMAND (SCR 274 N) EQUIPMENT

	Used	New
BC-453	\$12.95	
BC-454	4.95	\$6.95
BC-455	7.95	
BC-456	1.95	2.95
BC-457	5.95	
BC-458	5.95	
BC-459 (or T22)	9.95	
BC-696 (or T19)	14.95	24.95
BC-450—3 Receiver Remote Control	.80	1.95
BC-442		2.95
3 Receiver Rack	1.95	
2 Transmitter Rack	1.50	
BC 457 Transmitter—as is—fair condition—as they come, some with some less tubes and Xtal.	1.95	
BC 458 Transmitter—as is—fair condition—as they come, some with some less tubes and Xtal.	1.95	
Complete Command set as removed from aircraft—3 receivers—2 transmitters—Relay unit—control boxes—mounting racks—plugs—modulator and dynamotors—crated.		Set \$34.50

All shipments FOB Chicago, 20% Deposit required on all orders. Minimum order accepted—\$5.00. Illinois residents, please add regular sales tax to your remittance.



**GUARANTEED  
BRAND  
NEW**

**ELECTRONIC RESEARCH  
TUBE SPECIALS**

**STANDARD  
BRANDS  
ONLY**

RECEIVING TUBES	574	.79	6SR8GT	.95	12AU7	.86	50L6GT	.57	Thyratrons	3J31	39.25	WE-283A	1.27	814	3.79
OZ4	.59	6A4	6A8GT	.52	12AX7	.86	50	.95	OA4	SN-4/631-		304TH	3.86	815	1.72
OZ4G	.59	6A7	6A8GT	.72	12AX7	.86	55	.79	EL-C1A	PT	3.77	304TH	1.25	816	.97
1A3	.45	6AB7/1853	.99	6SC7GT	.61	12BA7	.86	1.15	2A4G	4A1	.58	WE-310A	7.50	826	.57
1A5GT	.54	6AC5GT	.94	6SD7GT	.79	12BE6	.46	.59	2D21	4B22/EL-	5.20	316A	.66	829	4.91
1A7GT	.69	6AC7/1852	.79	6SF5	.59	12C8	.57	.72	3C23	5B	5.20	350A	2.50	829B	6.20
1B3GT	.73	6AD6G	1.45	6SFGT	.59	12F5GT	.65	.72	3C31/EL-	4B24/EL-	2.44	350B	1.95	830B	3.35
1B3GT/8016	1.18	6AD7G	1.13	6SF7	.72	12H6	.39	1.24	C1B	4C35	3.35	350C	19.50	832	3.95
1B4P	1.15	6AE6G	.72	6SG7GT	.68	12H6	.39	.59	EL-C5B	4C35	3.35	4B25/EL-	4.75	832A	4.91
1B5/25S	1.16	6AF6G	.96	6SH7GT	.44	12K8	.69	.75	C6J	4C28	8.85	6CF	8.70	837	1.38
1C5GT	.69	6AG5	.89	6SH7GT	.44	12O7GT	.68	.59	FG-17	4E27	12.75	371B	2.95	838	2.93
1C6	.94	6AG7	1.19	6SHT	.59	12SA7GT	.59	.77	FG-33	5D21	26.50	487A	10.65	841	.49
1D5GP	1.04	6AJ5	.89	6SHT	.59	12SC7	.69	.80	FG-67/1904	5J23	14.20	434A	3.65	843	.59
1D5GP	1.04	6AK5	.89	6SHT	.59	12SK7	.65	.81	FG-81A	5J23	14.20	446A	4.75	851	27.50
1E5GP	1.16	WE-6AK5	1.35	6SL7GT	.69	12SK7	.65	.81	FG-105	6C21	19.88	471A	2.75	860	4.50
1E7G	.66	6AK6	.86	6SN7GT	.64	12SH7	.49	.82	FG-172	6J4	5.20	503AX	1.47	861	1.70
1G4GT	.79	6AL5	.69	6SN7W	1.45	12SJ7GT	.49	.83	WE355A	10T1	.58	506AX	1.47	864	.19
1G6GT	.79	6AO5	.72	6SO7	.53	12SK7	.65	.79	3A4	5J23	.19	507AX	1.47	866A	.95
1H4G	.69	6AO6	.65	6SO7GT	.53	12SK7	.65	.79	KU-610	15R	.75	527	9.75	869	27.00
1H5GT	.59	6AT6	.54	6SR7	.59	12SL7GT	.69	.79	KU-634	REL-21	3.25	530	17.20	872A	1.88
1J6G	1.04	6AU6	.72	6SS7	.65	12SN7GT	.69	.79	WL-652/657	24G	.44	531	17.80	874	1.65
1L4	.66	6AV6	.55	6ST7	.79	12SO7GT	.69	.79	884	RK-25	2.11	532A	3.15	876	.39
1L4A	.94	6B4G	.94	6T7G	1.15	12SK7	.65	.79	885	PG-32	4.25	559	1.41	878	1.85
1L4A	.94	6B8	.79	6T7G	1.15	12SK7	.65	.79	888	RK-34	.28	561	1.45	954	.39
1L5	.73	6B8G	.79	6U5/6G5	.72	14A4	.88	.92	894	REL-36	7.8	570B	5.85	955	.39
1L5	.73	6BA6	.65	6U7G	.65	14A7/12B7	.79	.88	1904	8K-47	4.92	HY615	2.99	956	.49
1L5	.73	6BA7	.65	6V6	1.07	14B6	.79	.79	2050	EF-50	.45	631-P1	3.77	957	.49
1L5	.73	6BE6	.86	6V6G	.59	14B8	.79	.79	2051	VT-52	.36	WL-670A	8.70	958A	.49
1LH4	.64	6BH6	1.72	6V6GT	.59	14C5	.79	.79	2051	53A	3.82	709B	16.90	991	.29
1LN5	.88	6BJ6	.72	6V6GT	.59	14D7	.79	.79	2051	53A	3.82	709B	16.90	1005	.29
1N5GT	.69	6C4	.21	6W4GT	.79	14J7	.86	.86	2AP1	55A	5.95	700D	16.90	1201A/7E5	.29
1N6G	.72	6C5	.21	6X4	.59	14N7	.86	.86	2AP5	3AP1	4.63	701A	3.67	1203/7C4	.19
1P5GT	.59	6C6	.69	6X5GT	.59	14W7	.96	.96	3AP4/906P4	3AP4/906P4	5.94	702A	2.95	1294/1R4	.29
1Q5GT	.94	6C6	.69	6Y6G	.88	14X7	.96	.96	1B22	1B22	3.87	702B	3.87	1299/3D6	.29
1R4	.29	6C8G	.94	6Z7G	1.09	19T8	1.16	1.16	1B23	75T	3.80	703A	3.90	1602	.68
1R5	.69	6D8G	.87	6Z7G	1.09	19T8	1.16	1.16	1B24	VR-78	3.80	704A	2.75	1613	.61
1S4	.64	6E5	.79	6Z7G	1.09	19T8	1.16	1.16	1B25	VR-90/OB3	.81	705A	5.22	1616	.87
1S4	.64	6E5	.79	6Z7G	1.09	19T8	1.16	1.16	1B26	VR-98	2.90	707B	6.95	1619	.19
1T4	.64	6F5	.60	6Z7G	1.09	19T8	1.16	1.16	1B27	(BR)	2.90	707B	6.95	1624	.69
1T5GT	.94	6F5GT	.60	6Z7G	1.09	19T8	1.16	1.16	1B28	C100E	2.30	708A	4.85	1624	.69
1U4	.72	6F7	.72	6Z7G	1.09	19T8	1.16	1.16	1B29	100R	2.90	710A	2.25	1625	.19
1V	.69	6F8G	.89	6Z7G	1.09	19T8	1.16	1.16	1B30	100TH	10.25	713A	1.45	1626	.29
2A3	.79	6G6G	.88	6Z7G	1.09	19T8	1.16	1.16	1B31	WE-101D	1.65	714AY	6.75	1629	.29
2A3	.79	6G6G	.88	6Z7G	1.09	19T8	1.16	1.16	1B32	WE-101F	3.62	715A	6.75	1630	3.11
2B7	.79	6H6GT	.48	6Z7G	1.09	19T8	1.16	1.16	1B33	VR-105/OC3	.72	717A	.97	1636	3.77
2E5	.94	6J5	.48	6Z7G	1.09	19T8	1.16	1.16	1B34	WE-113A	1.32	721A	3.93	1638	.70
2X2/879	.49	6J5GT	.48	6Z7G	1.09	19T8	1.16	1.16	1B35	WE-120A	1.47	723A/B	16.55	1641/RK-60	.59
2X2A	.79	6J6	.89	6Z7G	1.09	19T8	1.16	1.16	1B36	WE-121A	1.97	724B	3.22	1642	.39
3A4	.61	6J6	.89	6Z7G	1.09	19T8	1.16	1.16	1B37	WE-124A	3.80	724B	3.22	1642	.39
3A5	.96	6J7	.72	6Z7G	1.09	19T8	1.16	1.16	1B38	VT-127A	2.40	725A	8.95	1960	1.21
3A8GT	1.76	6J7GT	.72	6Z7G	1.09	19T8	1.16	1.16	1B39	VR-150/OD3	.65	726A	14.50	UX-6653	.65
3B7/1291	.29	6K5GT	.86	6Z7G	1.09	19T8	1.16	1.16	1B40	203A	6.40	730A	10.95	7193	.22
3C6(XXB)	1.15	6K6GT	.52	6Z7G	1.09	19T8	1.16	1.16	1B41	203B	4.33	731A	2.45	8005	4.65
3D6/1299	.29	6K7	.54	6Z7G	1.09	19T8	1.16	1.16	1B42	204A	27.90	WL787	1.80	8011	.87
3Q4	.69	6K7G	.54	6Z7G	1.09	19T8	1.16	1.16	1B43	WE-205B	1.70	800	1.88	8012	1.45
3Q5GT	.79	6K8	.83	6Z7G	1.09	19T8	1.16	1.16	1B44	CE-206	3.15	801A	.48	8012A	1.91
3S4	.61	6K8GT	.79	6Z7G	1.09	19T8	1.16	1.16	1B45	211	.62	802	4.25	8013	.92
3V4	.72	6L6	1.22	6Z7G	1.09	19T8	1.16	1.16	1B46	WE-215A	1.24	803	4.87	8013A	1.42
5A24	.48	6L6GA	.87	6Z7G	1.09	19T8	1.16	1.16	1B47	WE-215A	1.95	804	8.85	8016	1.18
5R4GY	.89	6L6GA	.87	6Z7G	1.09	19T8	1.16	1.16	1B48	WE-245A	1.35	807	4.75	8020	1.39
5U4G	.59	6L7	.87	6Z7G	1.09	19T8	1.16	1.16	1B49	WE-245A	1.35	807	1.15	9001	.42
5V4G	.84	6N7GT	.87	6Z7G	1.09	19T8	1.16	1.16	1B50	WE-249C	1.88	808	2.19	9002	.39
5W4	.76	6P7G	1.28	6Z7G	1.09	19T8	1.16	1.16	1B51	WE-257A	2.77	809	2.40	9003	.42
5X4G	.59	6Q7	.69	6Z7G	1.09	19T8	1.16	1.16	1B52	WE-259A	4.22	810	7.25	9003	.39
5Y3GT	.38	6R7	.89	6Z7G	1.09	19T8	1.16	1.16	1B53	WE-271A	6.75	811	1.91	9004	.39
5Y4G	.46	6S7	.89	6Z7G	1.09	19T8	1.16	1.16	1B54	WE-274B	1.06	813	6.95	9006	.29
5Z3	.65	6S7G	1.02	6Z7G	1.09	19T8	1.16	1.16	1B55						

**WESTINGHOUSE HYPERSIL TRANSFORMER**

PRI-115V. 60CY 1/4 KVA  
SEC #1 - 240V - 1.56A  
SEC #2 - 240V - 1.56A  
WT. 30 LBS.

**\$11.50 EACH**

**\$10.00 ea. Lots of 10**

**ASB YAGI ANTENNA**

5 ELEMENT ROTATABLE ARRAY—  
450 TO 560 MC **\$7.00**

SAME EXCEPT DOUBLE STACKED  
6 ELEMENT 450 TO 560 MC **\$12.70**

Same Except Double Stacked  
6 Element 370 to 430 MC **\$29.40**

**CAPACITORS**

MOLDED OIL-IMPREGNATED PAPER

.02 MFD	200 VDC	04 1/2 Ea.	\$3.00 per 100
.05	200	04 1/2	3.00
.1	200	06	4.00
.25	200	06	6.00
.1	400	09	3.00
.005	600	04 1/2	3.00
.01	600	06	4.50
.05	600	08	5.50

**METAL CLAD TUBULARS**  
OIL-IMPREGNATED—HERMETICALLY SEALED

.006 MFD	600 VDC	18 Ea.	\$12.00 per 100
.01	600	22 1/2	15.00
.1	600	28 1/2	19.00

**KOLLSMAN INSTRUMENT LOW INERTIA SERVO MOTOR**

Freq. Cycles	100	Res.—Phase 1	306 Ω
Volts—Phase 1	85	Res.—Phase 2	776 Ω
Volts—Phase 2	68	No. of Poles	4
Current—Phase 1	110MA	Speed—RPM	2650
Current—Phase 2	40MA	Weight—Oz.	6.5
Input Watts—No Load	2650 RPM CW		5.8
Input Watts—Stalled			5.0
Torque Stalled—(Oz. In.)			.80
Temp. Rise (°C)—2650 RPM—No Load			5.4
Temp. Rise (°C)—Stalled			5.4
Reversing Time—(Seconds)			0.1
Moment of			



# HUGE SURPLUS SALE of DELCO DUAL BLOWERS!

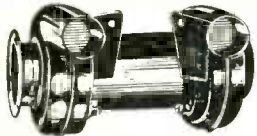

**ONLY**  
\$14.85 Ea. lots of 1-9  
\$13.95 Ea. lots of 10-49  
\$12.75 Ea. lots of 50-99

New and in original shipping cartons! Way, way, way below regular price! Built by Delco division of General Motors. Million household, commercial and marine uses: photo dark-rooms, cooling xmtr tubes, furnace draft boosting, machinery suction unit, humidifiers, hair dryers, kitchen ventilation, etc. No brushes to cause radio interference. Quiet, continuous duty 115 V 60 cycle Delco shaded-pole motor with skewed squirrel-cage type rotor. Two multi-blade squirrel-cage type fans and pressed-steel welded 2-piece snail type housing. Die cast alloy case and housings. Operates at 2800 rpm; 2750 fpm velocity, 120 cfm free volume air delivery. 62 watts input. Black lacquer finish. Weight 11 lbs. Over-all 10 21/32" by 5 27/32" by 6 7/32", with universal mounting brackets.

**\$19.50 Holtzer Cabot  
AC Synchronous Motor**



- Reversible!
- Gear-Reducer!
- A \$19.50 Value

Yours for ONLY

**\$6.95**

TYPE RBC 2503, compact 110/1/60 synchronous and reversible motor with a built-in gear reducer down to 2 r.p.m. 9 watts Torque 60 oz. in. Motor size 2 1/2 x 2 1/2" shaft 1" Like-new condition, mounted on aluminum frame with 8-terminal Jones strip and 1 mid capacitor. Replacement cost would be almost THREE TIMES our once-in-a-lifetime price!

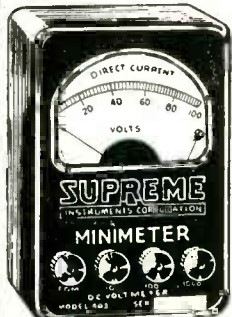

## HUGE SAVINGS ON NEW SUPREME MINIMETERS!

Boston's bargain-loving RADIO SHACK slashes dealer-net prices IN HALF with a special purchase of new (not surplus) SUPREME Minimizers. Saves \$\$\$ - and \$\$\$ on voltmeters, milliammeters, microammeters and ohmmeters! Servicemen, hams, experimental school and industrial users like their small size — 2 1/4 x 3 3/8 x 1 1/2" — only slightly larger than ordinary meter movements alone!

Description	Reg.	Sale
Model 403, DC volts: 0-10-100-1000	\$9.65	\$6.95
Model 404, DC volts: 0-2.5-25-250	9.65	4.95
Model 410, DC mls: 0-25-250-2500	9.65	4.95
Model 411, DC mls: 0-50-500-5000	9.65	4.95
Model 420, DC amps: 0-1, 0-1 0-10	10.65	5.95
Model 430, DC microamps: 50-0-50 500-0-500, 5000-0-5000, designed esp for alignment of FM receivers:	14.50	7.95
Model 440 DC ohms, 0-2000-20000-200000, center scale low range 25 ohms, complete with battery.	11.50	6.95

## Stewart-Warner DEMAND INDICATOR ONLY \$2.49, Worth 5-10 Times More!

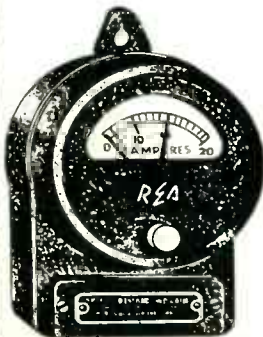

CUT current costs. INCREASE equipment life with 20 amp range, thermally operated Model 748A (Type RD) demand indicators for 600 volts or less. These 2-wire instruments are a "must" for Electrical Contractors, production lines, labs, colleges, electric sub stations. Accurately check transformer loading, load distribution! Determine proper current distribution! 6 watts at full indication. Crackle-finish metal case 4 1/2" W. 5 1/2" H. 2 3/4" D. 1 1/2 lbs. Brand NEW! Individually packed with data Only \$2.49 each!

# SALE

BELOW WHOLESALE

## Burlington Panel Instruments

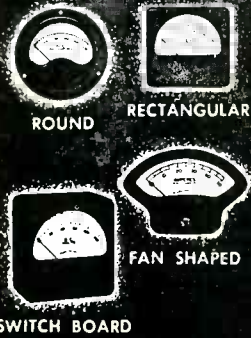

### DC VOLTMETERS

RANGE	DESCRIPTION	MODEL	PRICE
0-1	3 1/2" rd.	431	3.95
0-1	2 1/2" sq.	521	2.95
0-5	4 1/2" rd.	441	3.95
0-5	2 1/2" sq.	521	2.95
0-5	2 1/2" rd.	421	2.95
0-5	3 1/2" rd.	431	3.95
0-5	4 1/2" sw. board	441	3.95
0-10	3 1/2" rd.	431	3.95
0-10	4 1/2" rd.	441	3.95
0-15	3 1/2" rd.	431	3.95
0-15	4 1/2" rd.	441	3.95
0-15	3 1/2" rd.	431	3.95
0-15	4 1/2" rd.	441	3.95
0-20	4 1/2" sw. board	441	3.95
0-100	2 1/2" sq.	521	2.95
0-100	3 1/2" rd.	431	3.95
0-100	4 1/2" rd.	441	3.95
0-100	4 1/2" sw. board	441	3.95
0-100	3 1/2" rd.	431	3.95
0-100	4 1/2" rd.	441	3.95
0-100	4 1/2" sw. board	441	3.95
0-200	2 1/2" sq.	521	2.95
0-200	3 1/2" rd.	431	3.95
0-200	4 1/2" rd.	441	3.95
0-300	3 1/2" rd.	431	3.95
0-300	4 1/2" rd.	441	3.95
0-300	4 1/2" sw. board	441	3.95
0-500	3 1/2" rd.	431	3.95
0-500	4 1/2" rd.	441	3.95
0-500	4 1/2" sw. board	441	3.95
0-1000	4 1/2" sw. board	441	3.95

### DC MILLIAMMETERS

RANGE	DESCRIPTION	MODEL	PRICE
0-1	3 1/2" rd.	431	3.95
0-1	4 1/2" rd.	441	3.95
0-1	3" sq.	531	4.25
0-1	4 1/2" rd. (right hand zero)	441	4.50
0-5	2 1/2" rd.	421	2.95
0-5	2 1/2" sq.	521	2.95
0-5	3" sq.	531	3.50
0-5	4 1/2" sw. board	441	3.95
0-10	3 1/2" rd.	431	3.95
0-10	4 1/2" rd.	441	3.95
0-15	3" sq.	531	3.50
0-15	2 1/2" sq.	521	2.95
0-15	3" sq.	531	3.50
0-25	3 1/2" rd.	431	3.95
0-25	4 1/2" rd.	441	3.95
0-25	4 1/2" sw. board	441	3.95
0-50	3" sq. mod.	531	3.50
0-50	3 1/2" rd. mod.	431	3.50
0-100	2 1/2" sq.	521	2.95
0-100	3" sq.	531	3.50
0-100	4 1/2" sw. board	441	3.95
0-100	4 1/2" rd. (kentic edge pointer)	441	3.95
0-100	4 1/2" rd.	441	3.95
0-100	3" sq.	531	3.50
0-150	3 1/2" rd.	431	3.95
0-200	2 1/2" rd.	421	2.95
0-200	3" sq.	531	3.50
0-300	3" sq.	531	3.50
0-300	3 1/2" rd.	431	3.95
0-500	4 1/2" sw. board	441	3.95
0-500	4 1/2" rd.	441	3.95
0-750	2 1/2" sq.	521	2.95
0-750	4 1/2" sw. board	441	3.95
0-1000	2 1/2" rd.	421	2.95
0-1000	2 1/2" sq.	521	2.95
0-1000	3" sq.	531	3.50
0-1000	3 1/2" rd.	431	3.95
0-1000	4 1/2" rd.	441	3.95

### DC MICROAMMETERS

0-100	4 1/2" sw. board	441	4.50
0-200	3" sq.	531	3.50
0-200	3 1/2" rd.	431	3.95

### AC VOLTMETERS

RANGE	DESCRIPTION	MODEL	PRICE
0-1	2 1/2" sq.	522	2.95
0-1	3" sq.	532	3.50
0-1	3 1/2" rd.	432	3.95
0-1	4 1/2" sw. board	442	3.95
0-3	4 1/2" rd.	742	3.50
0-5	2 1/2" sq.	522	2.95
0-5	3" sq.	532	3.50
0-5	3 1/2" rd.	432	3.95
0-5	4 1/2" sw. board	442	3.95
0-10	2 1/2" sq.	522	2.95
0-10	3" sq.	532	3.50
0-10	3 1/2" rd.	432	3.95
0-10	4 1/2" rect.	742	3.50
0-15	2 1/2" sq.	522	2.95
0-15	3" sq.	532	3.50
0-15	3 1/2" rd.	432	3.95
0-15	4 1/2" sw. board	442	3.95
0-25	2 1/2" sq.	522	2.95
0-25	3" sq.	532	3.50
0-25	3 1/2" rd.	432	3.95
0-25	4 1/2" sw. board	442	3.95
0-25	4 1/2" rect.	742	3.50
0-30	2 1/2" sq.	522	2.95
0-30	3" sq.	532	3.50
0-30	3 1/2" rd.	432	3.95
0-30	4 1/2" sw. board	442	3.95
0-30	4 1/2" rd.	442	3.95
0-30	4 1/2" sw. board	442	3.95
0-50	2 1/2" sq.	522	2.95
0-50	3" sq.	532	3.50
0-50	3 1/2" rd.	432	3.95
0-50	4 1/2" sw. board	442	3.95
0-50	4 1/2" rect.	742	3.50
0-75	3 1/2" rd.	432	3.95
0-100	2 1/2" sq.	522	2.95
0-100	3" sq.	532	3.50
0-100	3 1/2" rd.	432	3.95
0-100	4 1/2" sw. board	442	3.95
0-100	4 1/2" rd.	442	3.95
0-100	4 1/2" sw. board	442	3.95
0-150	2 1/2" sq.	522	2.95
0-150	3" sq.	532	3.50
0-150	3 1/2" rd.	432	3.95
0-150	4 1/2" sw. board	442	3.95
0-150	4 1/2" rect.	742	3.50
0-200	2 1/2" sq.	522	2.95
0-200	3" sq.	532	3.50
0-200	3 1/2" rd.	432	3.95
0-200	4 1/2" sw. board	442	3.95
0-200	4 1/2" rect.	742	3.50
0-250	2 1/2" sq.	522	2.95
0-250	3" sq.	532	3.50
0-250	3 1/2" rd.	432	3.95
0-250	4 1/2" sw. board	442	3.95
0-250	4 1/2" rect.	742	3.50
0-300	2 1/2" sq.	522	2.95
0-300	3" sq.	532	3.50
0-300	3 1/2" rd.	432	3.95
0-300	4 1/2" sw. board	442	3.95
0-300	4 1/2" rect.	742	3.50
0-300	4 1/2" fan shaped	842	4.95
0-600	3 1/2" rd. (300v. mov't) w/res.	432	4.50
0-600	4 1/2" rect.	742	4.95
0-600	4 1/2" rd.	442	4.95

### AC AMMETERS

RANGE	DESCRIPTION	MODEL	PRICE
0-1	3" sq.	532	\$3.95
0-1	3 1/2" rd.	432	4.25
0-1	4 1/2" sw. board	442	4.25
0-1	4 1/2" rect.	742	4.25
0-1.5	2 1/2" rd.	422	3.25
0-1.5	2 1/2" sq.	522	3.25
0-1.5	3" sq.	532	3.25
0-1.5	3 1/2" rd.	432	4.25
0-1.5	4 1/2" rect.	742	4.25
0-1.5	2 1/2" sq.	522	3.25
0-1.5	3" sq.	532	3.25
0-1.5	3 1/2" rd.	432	3.95
0-1.5	4 1/2" sw. board	442	4.50
0-1.5	4 1/2" rect.	742	4.50
0-1.5	3" sq.	532	3.50
0-10	3 1/2" rd.	432	3.50
0-10	4 1/2" sw. board	442	3.50
0-10	4 1/2" rd.	442	3.50
0-10	4 1/2" rect.	742	3.50
0-10	2 1/2" sq.	522	2.95
0-10	3" sq.	532	2.95
0-10	3 1/2" rd.	432	2.95
0-10	4 1/2" sw. board	442	2.95
0-10	4 1/2" rect.	742	2.95
0-10	4 1/2" fan shaped	842	2.95
0-10	3" sq.	532	3.50
0-10	3 1/2" rd.	432	3.50
0-10	4 1/2" sw. board	442	3.50
0-10	4 1/2" rect.	742	3.50
0-10	4 1/2" fan shaped	842	3.50
0-10	3" sq.	532	3.50
0-10	3 1/2" rd.	432	3.50
0-10	4 1/2" sw. board	442	3.50
0-10	4 1/2" rect.	742	3.50
0-10	4 1/2" fan shaped	842	3.50
0-10	3" sq.	532	3.50
0-10	3 1/2" rd.	432	3.50
0-10	4 1/2" sw. board	442	3.50
0-10	4 1/2" rect.	742	3.50
0-10	4 1/2" fan shaped	842	3.50
0-10	3" sq.	532	3.50
0-10	3 1/2" rd.	432	3.50
0-10	4 1/2" sw. board	442	3.50
0-10	4 1/2" rect.	742	3.50
0-10	4 1/2" fan shaped	842	3.50
0-10	3" sq.	532	3.50
0-10	3 1/2" rd.	432	3.50
0-10	4 1/2" sw. board	442	3.50
0-10	4 1/2" rect.	742	3.50
0-10	4 1/2" fan shaped	842	3.50
0-10	3" sq.	532	3.50
0-10	3 1/2" rd.	432	3.50
0-10	4 1/2" sw. board	442	3.50
0-10	4 1/2" rect.	742	3.50
0-10	4 1/2" fan shaped	842	3.50
0-10	3" sq.	532	3.50
0-10	3 1/2" rd.	432	3.50
0-10	4 1/2" sw. board	442	3.50
0-10	4 1/2" rect.	742	3.50
0-10	4 1/2" fan shaped	842	3.50
0-10	3" sq.	532	3.50
0-10	3 1/2" rd.	432	3.50
0-10	4 1/2" sw. board	442	3.50
0-10	4 1/2" rect.	742	3.50
0-10	4 1/2" fan shaped	842	3.50
0-10	3" sq.	532	3.50
0-10	3 1/2" rd.	432	3.50
0-10	4 1/2" sw. board	442	3.50
0-10	4 1/2" rect.	742	3.50
0-10	4 1/2" fan shaped	842	3.50
0-10	3" sq.	532	3.50
0-10	3 1/2" rd.	432	3.50
0-10	4 1/2" sw. board	442	3.50
0-10	4 1/2" rect.	742	3.50
0-10	4 1/2" fan shaped	842	3.50
0-10	3" sq.	532	3.50
0-10	3 1/2" rd.	432	3.50
0-10	4 1/2" sw. board	442	3.50
0-10	4 1/2" rect.	742	3.50
0-10	4 1/2" fan shaped	842	3.50
0-10	3" sq.	532	3.50
0-10	3 1/2" rd.	432	3.50
0-10	4 1/2" sw. board	442	3.50
0-10	4 1/2" rect.	742	3.50
0-10	4 1/2" fan shaped	842	3.50
0-10	3" sq.	532	3.50
0-10	3 1/2" rd.	432	3.50
0-10	4 1/2" sw. board	442	3.



# Reliance Specials

## RG 8/U 52 OHM

\$50.00 per 1,000 feet  
OTHER COAXIAL CABLE  
ALL BRAND NEW

	Price per 1,000 ft.		Price per 1,000 ft.
RG 5/U	53.5	RG 27/U	48
RG 7/U	97.5	RG 29/U	53.5
RG 8/U	52	RG 31/U	71
RG 9/U	51	RG 39/U	75
RG 10/U	52	RG 41/U	57.5
RG 11/U	75	RG 54/U	58
RG 12/U	75	RG 54/AU	58
RG 13/U	75	RG 55/AU	53.5
RG 18/U	52	RG 57/U	95
RG 19/U	52	RG 58/U	53.5
RG 20/U	52	RG 59/U	73
RG 22/U	95	RG 62/U	93
RG 24/U	125	RG 74/U	52
RG 25/U	48		

POSTAGE STAMP MICAS				CAPACITORS				OIL FILLED	
MMF	MMF	MMF	MFD	SILVER MICA				MFD	V. D. C.
8.2	56	240	600	MMF	MMF	MMF	MFD	.375@	16,000 and
10	60	250	620	24	150	370	680	.75@	8,000 (dual)
15	62	300	650	25	180	390	700	.4	10,000
20	68	350	680	30	200	400	750	.5	7,500
22	70	370	700	40	208	430	820	.1	7,500
24	75	390	750	60	225	466	MFD .0047	-.1	7,000
25	82	400	800	62	240	470	.005	.02-.02	7,000
30	90	430	820	66	250	488	.0013	1	6,000
39	100	470	910	68	300	500	.0015	.25	4,000
40	110	500	MFD .0068	75	325	510	.002	2	3,000
47	150	610	.001	110	525	.0022	.01	4	2,000
50	160	650	.0012	120	560	.0024		4	1,000
51	220	680	.0013					3	1,000
Price Schedule				Price Schedule					
8.2	MMF to	.001	MFD... 5¢	10	MMF to	.001	MFD... 10¢	10	1,000
.012	MFD to	.002	MFD... 7¢	.0012	MFD to	.0027	MFD... 20¢	10	600
.0026	MFD to	.0082	MFD... 12¢	.003	MFD to	.0082	MFD... 50¢	4	600
.01	MFD		18¢	.01	MFD		65¢	2	600

## COAXIAL CABLE CONNECTORS

Angle-Adapter	Plug	Socket	Hood
15c	28c	28c	9c
M-359	PL-259A	SO-239	83-IH
83-IAP	83-ISPN	83-IR	

Adapter for PL-259 A for use on small coax.  
12c each. \$10.00 per 100

83-ISIP	\$.28	83-22SP	.48	UG 27/U	.60
83-IJ	1.00	83-2	1.50	UG 59/U	.60
83-IT	1.12	UG 13/U	.60	UG 61/U	.60
83-IF	1.12	UG 21/U	.60	UG 85/U	.60
83-22AP	.85	UG 22/U	.60	UG 87/U	.50
83-22J	.85	UG 24/U	.60	UG 167/U	2.00
83-22R	.48	UG 25/U	.60	UG 281/U	.60

### SELSYNS

115 V., 60 Cyc.  
#C78248  
3 3/8" dia. x 5 3/8" long  
\$7.95 pair

Mounting Brackets — (Bakelite) for selsyns, and differentials shown above ..... 25¢ pair

### DIFFERENTIAL

115 V., 60 Cyc.  
#C78249  
3 3/8" dia. x 5 3/8" long  
\$2.25 ea.

Used between two #C78248's as dampener. Can be converted to 3600 RPM Motor in 10 minutes. Conversion sheet supplied. (Converted—\$3.00)

### WW PRECISION RESISTORS, 1% OR BETTER

1/4 WATT—25c			
6.68Ω	12.32Ω	16.37Ω	123.8Ω
10.48	13.02	20	147.5
10.84	13.52	62.54	270.4
11.25	13.89	79.81	301.8
11.74	14.98	106.8	366.6

1/2 WATT—25c			
.250Ω	11.10	210Ω	3,427Ω
.334	13.15	235	4,000
.502	46	260	4,451
.557	52	270	5,000
.627	55.1	298.3	5,900
.76	73	340	6,500
1.01	97.8	723.1	7,000
1.53	125	2,500	7,500
2.04	180	2,850	8,000

1 WATT—30c			
1.01Ω	5.21Ω	1,250Ω	9,000Ω
2.58	10.1	3,300	18,000
3.39	10.9	7,000	70,000
5.05	270		

1 WATT—40c			
100,000Ω	128,000Ω	180,000Ω	522,000Ω
120,000	130,000	320,000	600,000
125,000	160,000	470,000	700,000

1 Megohm—1 Watt 1%—65c; 5%—40c  
100 pieces—10% off; 1,000 pieces—20% off.

## CARBON RESISTOR ASSORTMENT

Color coded, insulated. 100 only \$1.29

### PULSE TRANSFORMERS

X 124, T2, UTAH, marked 9262, small gray case. Ratio 1:1.1, hypersil core. .... \$1.50  
D16110, 50 Kc to 4 Mc. 1 3/4" dia. x 1 1/2" high. 120 to 250 ohms. .... \$1.50  
352-7178—Spec. 10. 111 Chicago Trans. equivalent to 9262 (above) ..... \$1.00  
D166638 W.E. Permalloy core. Semi-toroidal windings \$1.25  
K98900, Ratio, 1:1.1, 2:1, Freq. range 380 to 520 C.P.S. .... \$3.50  
D106173, W.E. Freq. resp. 10KC to 2 MC. .... \$9.80  
300 KVA GE K 2468B, 50 ohm pulse cable connection; 3,350 V. in., 17,300 V. out (250 KVA @ 1/2 microsecond) ..... \$13.75  
800 KVA GE K2731., 28000 Volt pk. output; Bifilar; one-microsecond pulse width ..... \$14.50

### UNIVERSAL JOINT

3/16" hole x 3/8" O.D.  
1 1/8" long  
Steel or Aluminum  
50¢

### FILAMENT TRANSFORMER

Amertran Type WS  
For High Voltage Rectifiers.  
PRI. 115V., 50/60 Cycle.  
SEC. 5V., C/T @ 10 Amp.  
35 KV R.M.S. Test 12 KV D.C.  
Operating. Uses 872A Tube or other tubes.  
NEW OVERSEAS PACKED \$10.95  
872-A ..... \$1.88

### JONES BARRIER STRIPS

Type	Price	Type	Price	Type	Price
2-140Y	\$.05	4-141 1/2 W	\$.22	6-141 1/2 W	\$.47
2-140W	.10	4-141Y	.22	9-141Y	.47
3-140 1/2 W	.13	5-141	.20	10-141 1/2 W	.52
4-140	.13	5-141Y	.27	12-141	.44
8-140	.23	5-141 1/2 W	.27	17-141Y	.87
8-140W	.23	6-141	.23	3-142	.15
10-140 1/2 W	.40	7-141	.27	5-142	.24
13-140	.37	7-141 1/2 W	.37	6-142	.28
3-141 1/2 W	.17	7-141Y	.37	10-142 1/2 W	.44
3-141W	.17	8-141	.30	2-150	.28
4-141Y	.22	8-141 1/2 W	.42	4-150	.52

### TOGGLE SWITCHES

Bat Handle, S.P.S.T. 6A, 125V. Off-On plate. .... 24¢  
Bat Handle, S.P.D.T. 6A, 125 V. .... 24¢  
Bat Handle D. P. S. T. 6A, 125V. .... 29¢

### DRY DISC RECTIFIERS

117 V.A.C. in, 110 V.D.C. out @ 75 Ma. .... \$ .49  
117 V.A.C. in, 110 V.D.C. out @ 100 Ma. .... .72  
117 V.A.C. in, 110 V.D.C. out @ 400 Ma. .... 1.51

### DELAY NETWORK—ALL 1400 Ω

T 113—Approx. 1.2 micro sec. delay. .... 85¢  
T 114—Approx. 2.2 micro sec. delay. .... 85¢  
T 115—Similar to T 114 with tap brought out. .... 85¢

Telephone Field Wire—W110B, 1/2 mile reels. .... \$6.95

### TRANSMITTING MICAS UPRIGHT BAKELITE CASE

MFD	V. D. C.	Amps	KC	Price
.00032	5,000	2.5	1,000	\$1.19
.0005	5,000	4	1,000	1.19
.0011	5,000	6	1,000	1.24
.002	5,000	4	300	1.29
.015	2,000	12	300	1.34
.024	1,500	15	1,000	1.39
.033	1,500	15	1,000	1.39
.05	1,500	13	300	1.59
.062	1,000	18	1,000	1.49
.075	1,000	18	1,000	1.49

### ALLEN SET SCREWS

4-40 x 1 1/4	8-32 x 1/2	8-32 x 5/16
4-40 x 3/16	8-32 x 3/16	8-32 x 3/8

ALL SIZES (Cup Point) ..... \$1.50 per 100  
GLYPHTAL CEMENT 1 qt. .... 75¢ 1 gal. .... \$2.50

### VERNIER DIAL (From BC-221)

Marked 0-100 in 360°. Black with silver marks. 2 5/8" Dia. Has thumblock. .... 85¢

### Wrapped—BALL BEARINGS—New

Mfg	ID	OD	Width	Price
Fafnir 33K5	3/16"	7/32"	5/32"	.25
N.D. 38	5/16"	7/8"	9/32"	.45
Fafnir K8A	1/2"	1 1/8"	5/16"	.60
N.D. 5202C13M	1/2"	1 3/8"	1/8"	1.00
Fafnir 7308W	1 37/64"	3 9/16"	5/16"	2.00
SKF 466430	6"	6"	7/16"	5.00
SKF170545	3 11/32"	4 1/8"	7/16"	1.50
Fafnir 545	2 1/16"	2 5/8"	15/32"	1.00

### GEAR ASSORTMENT

Experimenters dream, 100 pieces, many stainless steel. .... \$6.50

3AG	FUSES	3AG
1/2 Amp \$4.00 per 100	2 Amp \$2.50 per 100	
1/4 Amp 4.00 100	3 2.50 100	
1/8 4.00 100	4 2.75 100	
1 2.50 100	5 3.00 100	
1 1/2 2.50 100	15 3.00 100	

Fuse Holder—Littlefuse #442001 for 3AG fuse. .... 18¢

### TIME DELAY RELAY

Raytheon CPX 24166 KS 10193-80 Sec.  
• 115 V., 60 Cycle • Adj. 50-70 Seconds •  
• 2 1/2 second cycling time—spring return •  
• Micro-switch contact, 10A. • Holds ON as long as power is applied • Fully cased ONLY ..... \$6.50

### NEEDLE BEARINGS

B108 1/2" wide	5/8"	13/16"	30¢
GB34X 1/4" wide	3/16"	11/32"	25¢

### PRECISION CONTROLS

6 WATT		4 WATT	
20,000 Muter 314A	\$1.70	500Ω Centralab 48-501	\$9.00
20,000 GR 314A	2.50	50 De jur 292	.75
6,000 De jur 260	1.70	50 GR 301	1.10
6,000 Muter 314A	1.70	25 GR 301	1.10
5,000 Muter 314A	2.50	20 De jur 292	.75
5,000 GR 214A	1.40	12 GR 301	1.10
2,000 De jur 260	1.70		

25 WATT		12 WATT	
10,000 Muter 471A	\$2.00	10,000 Muter 271T	2.00
10,000 De jur 271T	2.00	5,000 De jur 271T	2.00

7 Terminal Bakelite tie point. .... 35 for \$1.00

### O-15A BASIC MOVE DC AMMETER

5" x 4" METAL CASE MIRROR SCALE  
Lots of 10—\$34  
\$3.85 ea.

### CHOKE

400 MA  
12 Hy.  
90 OHM  
6,000 V. D. C. TEST  
\$3.85  
10 for \$34.00

### SOUND POWERED HANDSET

Brand New! T5-10  
Includes 6 ft. cord & spring clips  
\$9.92 ea. \$17.60 pr.

### WALL HANGER

Navy type, for Sound Powered Phones (Shown above) ..... \$1.00 each

### HAYDON TIMING MOTORS

4 R.P.M., 115V., 60 Cycle. .... \$1.79  
2/3 R.P.M., 115 V., 60 Cycle. 2 motors connected on one shaft to make unit reversible. ONLY ..... \$1.95

WRITE FOR MONTHLY BULLETIN

### POWER RHEOSTATS STANDARD BRANDS

25 WATT		25 WATT		90Ω 1/2"	
Resist. Shaft		3,000Ω	1 1/2"	123	1 1/2"
10Ω	1 1/2"	5,000	S.D.* 69	1,250	1 1/2"
15	1 1/2"			2,000	1 1/2"
25	1 1/2"			3,500	1 1/2"
145	1 1/2"	50 WATT		150 WATT	
		2Ω	1 1/2"	8Ω	1 1/2"
		8	S.D.* 79	75	1 1/2"
		12	1 1/2"		
		20	1 1/2"		

\*S.D. Screw Driver Slot

# RELIANCE MERCHANDIZING CO.

Arch St. Cor. Croskey Phila. 3, Pa. Telephone Rittenhouse 6-4927



# Portable (Chronometric) TACHOMETER

Jaeger Watch Co. Model #43A-6

- Can be used for speeds up to 20,000 R.P.M.
- Can be used for lineal speed measurements to 10,000 F.P.M.
- Ideally suited for testing the speeds of motors, particularly of fractional horse power, generators, turbines, centrifugals, fans, etc.
- Very small Torque—requires practically no power to drive.
- Unequaled Readability 2" Open face dial—each division on large dial equals 10 R.P.M.; each division on small dial equals 1,000 R.P.M.
- Greatest Accuracy—meets Navy specifications—guaranteed to be within 1/2 of 1%.
- Results of test reading remain on dial until next test taken.
- Push button for automatic resetting.
- Complete with the following accessories:
  - 1—Large pointed rubber tip
  - 1—Large hollow rubber tip
  - 1—6" circumference wheel tip
  - 1—Operating Instructions
  - 1—Temperature Correction chart

The combination of the above features will give accurately, within a few seconds, by direct reading, the R.P.M. of shafts or the lineal speeds of surfaces without any accessories or timing of any kind. Each unit comes complete in a red velvet lined carrying case 5" x 3 1/4" x 1 1/2" (case and accessories not illustrated). **Net List Price, \$75.00**—Surplus—New—Guaranteed.

**Your Cost \$24.50 fob, N. Y.**



## Multiple Range Continuous Indicating PORTABLE TACHOMETER

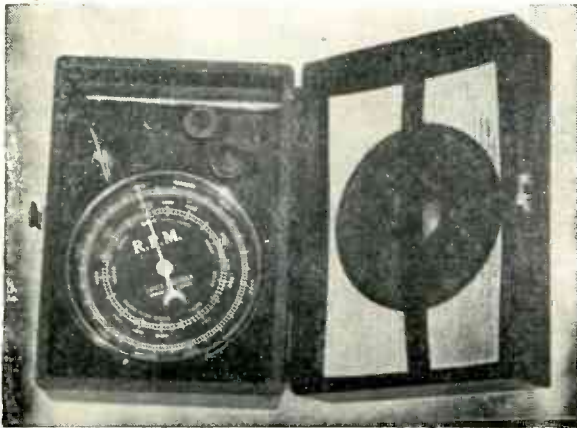

This unit is of the centrifugal mechanical type and is designed to show **INSTANTANEOUSLY and CONTINUOUSLY THE SPEED OR CHANGE IN SPEED** of any revolving shaft or surface. No stop watch or other mechanism required.

- Three ranges in R.P.M., and three ranges in F.P.M.
- Low Range... 300-1,200 (Each division equals 10 R.P.M.)
- Medium Range 1,000-4,000 (Each division equals 20 R.P.M.)
- High Range 3,000-12,000 (Each division equals 100 R.P.M.)
- Large open dial 4" diameter.
- Ruggedly constructed for heavy duty service.

- 1—Peripheral Rubber wheel 1 ft. in circumference
- 1—Extension Rod
- 1—Small size convex rubber tip, metal mounted

1—Operating instruction  
Made by Jones Motrola, Stamford, Connecticut. Comes complete in blue velvet lined carrying case: 7 1/4" L x 4" H x 5" W. **List Price \$75.00**—Surplus—New—Guaranteed.

**Your Cost \$24.50 fob, N. Y.**

- Ball bearing and oilless bearings—require no lubrication whatsoever.
- Readily portable—Fits neatly into palm of hand.
- Gear shift for selecting low, medium and high ranges.
- Greatest accuracy—meets Navy specifications 18-T-22, Type B, Class A.
- Complete with the following accessories:
  - 1—Steel tip
  - 1—Conical Rubber tip metal mounted
  - 1—Rubber lined metal cone tip

### BC-1161-A RADIO RECEIVER

150 to 210 Megacycles. Operates off 115 volt 60 cycle Power supply. Inductance tuning for R.F., Antenna, detector and oscillator. With a few modifications this unit makes an ideal F.M. Receiver. Each set complete with circuit diagram and the 14 following tubes: 1—6SN7 Cathode Follower; 1—6H6 second Detector; 2—6SH7 1st and 2nd R.F. Amp.; 1—6SH7 Video Amp.; 3—6AC7/1852 1st, 2nd, 3rd IF Amp.; 2—6AB7/1853 4th, 5th IF Amp.; 1—9006 Mod.; 1—6J5 Osc.; 1—5U4G Rect.; 1—6E5 Tuning Indicator.  
Complete in a metal cabinet 10" high 16 1/2" wide and 15" deep @ \$34.50

### BC-1160-A TRANSMITTER

157 to 187 Megacycles. Operates off 117 Volt 60 cycle. Contains 115 volt, 1525 R.P.M. Blower General Radio 200 B 1.5 Amp. Variac 10 tubes, 0-5 Kilovolt 3 1/2" meter transformers, relays, circuit breakers too numerous to list. Complete in metal cabinet 17 1/2" x 18 1/2" x 18" with circuit diagram. @ \$29.50

### SOCKET SELECTOR SET WESTON 666 TYPE 1C

Designed for purpose of taking readings of currents, voltages and resistance and other electrical measurements in a vacuum tube circuit. It can be used with many Western Analyzers or other make multirange volt-ohm-milliammeters. To test a tube circuit the tube is plugged into the appropriate adapter and the test plug inserted in the tube socket. This brings all currents and voltages out through a cable where they may be measured with an analyzer.

Complete with Tube Base Data Connections and Chart, 15 Adapters, pin leads and test block.  
**List Price \$30.00**—Your Cost \$9.50

### MINIATURE MILLIAMMETERS

BULOVA WATCH CO., type G-1, 1.25 M.A. 500 M.V. movement, 1 3/4" square flush bakelite case, 1 7/16" barrel diameter, 1 3/16" overall depth behind flange @ \$4.50

### ROLLER-SMITH, Type G-1

1.25 M.A.; 500 M.V. movement, 1 3/4" Square flush Bakelite case, 1 1/2" Barrel Diameter, 1 3/8" overall @ \$4.50



### Weston 433 PORTABLE A.C. VOLTMETER

FREQUENCY RANGE 25 to 2400 CYCLES 0-150 Volts, Weston 433, Accuracy within 3/4 of 1% on A.C. from 25 to 1000 Cycles and within 1 1/4% up to 2400 Cycles. Knife edge pointer; hand calibrated mirror scale; shielded moving iron vane movement; Resistance approximately 2800 Ohms. Scale length 4.04", in case 5" x 6" x 3 1/4". Similar to illustration. **Your Cost Only \$35.00**

### GASOLINE HEATER MOTOROLA Model GN-3-24

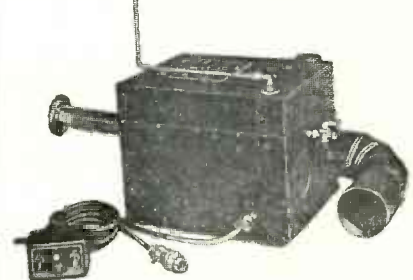

An internal combustion type heater which will give 15,000 B.T.U. of heat per hour. Ideally suited for use with equipment, farms, boats, bungalows, cabins, trailers, work sheds, darkrooms, mobile equipment, transmitter stations, etc., and any place where a quick heat is required in volume. Very economical in operation—tank holds one gallon of gasoline which is sufficient for 6 hours operation. Uses any grade gasoline. This unit is designed primarily for aircraft installation, 24-28 volts d.c., but can be readily adapted for a 115 or 230 volt 60 cycle power supply by use of a transformer and rectifier. Simple circuit diagram for adaptation to 115 or 230 volt 60 cycle use supplied with each unit. Can be used on 32 volt farm or boat systems as is without the installation of additional transformers, etc. Power consumption approximately 75 to 100 watts. Takes very little space—can be readily stored when not in use—measures approximately 12" long x 9 1/2" high x 9 1/2" wide, weighs only 30 lbs complete with all accessories. These units are complete with exhaust pipe, 3" air duct elbow, control switch and cord, as illustrated, and are supplied with Technical Manual and Parts Catalog.

**SIMPLE TO INSTALL—SAFE TO USE—NO ODORS**

**BRAND NEW—IN ORIGINAL CARTONS—READY TO USE**

Made by Galvin (Motorola) Mfg. Company.

**NET PRICE \$22.50**

### PORTABLE A.C. AMMETER WESTON MODEL 528

DUAL RANGE 0-3 Amp. and 0-15 Amp. full scale for use on any frequency from 25 to 500 cycles. The ideal instrument for all commercial, industrial, experimental, home, radio, motor and general repair shop testing. Comes complete with a genuine leather, plushlined carrying case and a pair of test leads. A very convenient pocket sized test meter priced at less than 50% of manufacturers list. **Your cost ONLY \$12.50**

### COMBINATION OFFER

150 VOLT A.C. METER | 30 AMP A.C. METER  
Triplet 331-JP, 3 1/2" | Triplet 331-JP, 3 1/2"  
Rd flush case | Rd flush case  
**Both meters for \$7.95**

ALL ITEMS ARE BRAND NEW-SURPLUS-GUARANTEED UNLESS SPECIFIED OTHERWISE. All materials shipped from stock same day as order received, subject to prior sale. Orders accepted from rated concerns, public institutions and agencies on open account, others please send 25% deposit, balance C.O.D. or check with order. All prices FOB our warehouse, N.Y.C.

**MARITIME SWITCHBOARD**  
338 CANAL STREET  
NEW YORK 13, N. Y.  
Worth 4-8217

We carry a complete line of surplus new meters suitable for every requirement, such as portable, panel, switchboard, laboratory standard, etc.

**Over 50,000 METERS in Stock**

We carry a wide assortment of aircraft type electrical meters, precision tubular multipliers and meter shunts. Your inquiries will receive our prompt attention.



# SUPERIOR VALUES FROM AMERICA'S LARGEST ELECTRICAL CONVERSION HOUSE

## ALLIS-CHALMERS MOTOR GENERATORS

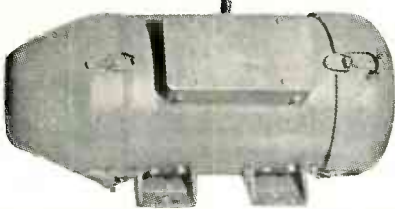

Input: 115 VDC at 14 amps. 3600 RPM. Ball Bearings. Output: 1.25 KVA; 80% PF 120 Volts, AC, 1 Ph. 10.4 amp. Centrifugal automatic controller permits line-start operation. Fully enclosed. Brand New \$99.95. Also available for 230 VDC operation at the same price.

## GEN. ELECTRIC TRANSFORMERS



1 KVA: 460/230-230/115. Brand New \$19.00  
General Electric 5 KVA Auto-transformers: 110/220. Brand New \$26.00



Westinghouse Transformer Controller contains 300 watts 110-220 volt transformer with multi-taps. The transformer with tap switch alone is worth more than the special price. \$6.25

## ESCO DC/DC MG SET

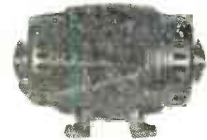

Operate at 220 Volts, DC to deliver 110 Volts, 3.5 amperes. Two of these units can be used on 220 VDC to obtain 110-0-110 Volts DC. Special Price \$15.54

GE Relays: 110 VAC—10 Amp. 50/60 cy. in steel case 5 x 5 x 6 1/2. \$3.90  
Shaded Pole Motor with gear train on mounting bracket. 110 VAC. \$1.65  
ONAN 800 CYCLE MG SETS; Operative at 110/220 VAC, 1  $\phi$ , 60 cyc. belted to alternator rated 1.2 KVA; 115 V, 1  $\phi$ , 800 Cy. \$251.00  
Above unit with 220/440-3-60 motor. \$227.00  
ONAN 500 CYCLE MG SETS; 4 KVA—Operative with 110/220 VAC, 1  $\phi$ , 60 Cy. Motor, rep-ind. Output single ph. \$450.00  
With 3 Ph. 220/440 Motor. \$395.00  
HIGH FREQUENCY MG UNIT. Made by Quality Elect. Operates at 115 VAC, 1  $\phi$ , 60 cy. delivers: 115 VAC, .87 amp. 3000 C. P. S., also 500/1000 VDC at 25/3 amp. self excited, with panel containing starting control. Unit is 30" long, weighs 200 lbs. \$145.00  
Westinghouse Precipitron Transformers. Pri. 110 V. Sec. 12,000 Volts, 18 MA. \$3.98  
Waukesha 4 cylinder gas engines 10 HP with pulley take-off, crank starting. Brand New \$148.50

## G.E. OIL FILLED OUTDOOR TRANSFORMER



Brand New. 3 KVA; Type HS 3000/5200Y-115/230. SPECIAL PRICE. Brand New \$36.00



General Electric "Variae type" Controllers; 600 watts; 110/220 designed as an adjustable speed controller but can be used for any application requiring a variable transformer. Brand new and an exceptional buy at \$12.00

GENERAL ELECTRIC 8 KW High Voltage Generators; Rebuilt like new, double commutator type each rated at 4000 Volts, DC, 2.5 amperes; can be connected in series to give 8000 Volts, DC at 2.5 amperes or 4000 volts, 5 amperes in parallel. Separately excited. Units weigh about 800 pounds. Offered at a fraction of their original cost. \$136.00

**IF IT'S FROM ONE FREQUENCY TO ANOTHER; FROM DC TO AC OR AC TO DC;  
IF IT'S FROM ONE VOLTAGE TO ANOTHER, THEN CALL ON US.**

Established in 1922  
409 ATLANTIC AVE.

## WILLIAM I. HORLICK COMPANY

Tel HANcock 6-2480  
BOSTON, 10, MASSACHUSETTS

## HOLTZER-CABOT MG 149F

Input 28 Volts, DC at 36 amps. Output 26 Volts at 250 V. A. 400 cps. and 115 Volts at 500 V. A., 400 cycles. Rebuilt like new \$24.75



## FLEXARC TRANSFORMER TYPE WELDER

Operates at 440/550, single phase, 60 cycles, 300 ampere adjustable output. Rebuilt like new. SPECIAL PRICE \$119.75

## GEN. ELECTRIC AMPLIDYNES



Model 5AM78AB16; 750 watts; Input: 440-3-60; Output: 250 Volts, DC; 2 amperes; 3450 RPM \$115.00  
Coupled directly to control motor on common base. Brand new \$185.00

Model 5AM73AB58; 375 watts; Input: 110/220 v. 1  $\phi$ , 60 cy. Output: 250 VDC, 1.5 Amp. \$58.00

Model 5AM78AB111; 1500 watts; Input: 208 V. 3  $\phi$ , 60 cy. Output: 250 VDC, 6 amp. \$225.00

ONAN HIGH FREQUENCY MG UNITS  
Input: 110/220, single phase, 60 cyc. Output: .6 K.W. 115 VAC, single ph. 430 cps. Rebuilt like new \$138.50

## G. E. Motor CONTROLLED VOLTAGE REGULATOR



Cat. #837625. Type AIRS, Form M, 568 KVA, cont. duty, 60 cy., primary volts 115. Load Amps 16.2. Indoor service. Voltage controlled by mtr. 120/1/60. 1/40 HP. \$39.50



Ideal AC to DC MG set 300 watts. Rebuilt like new. Ideal MG Set, operative at 110/220 VAC, single phase. Output: 120 VDC, 2.5 amperes. Special Price \$65.00



## ESCO CONVERTERS

Rebuilt like new. Input: 86 VDC 2.85 amp. 3600 R.P.M. Output 115 VAC, 2.18 amp. 50 P.F. Ball Bearings. Base for table or side mounting. Special \$9.80

ESCO DC/AC MG SETS. Motor: 115 Volts. 1 1/2 HP, line start; built in voltage regulator, frequency control, filtered; ideal for television, radar or any application requiring constant voltage and frequency. Brand New \$120.00

## LELAND-MURRAY HIGH FREQ. MOTOR GENERATOR SETS



3 KVA; 120 Volts, 3 Phase, 400 cycles, coupled to 220/440-3-60 Motor. \$335.00  
Same unit with 5 HP-110/220 Volt Motor \$415.00

Electric Specialty High Frequency Converter Units. Primary: 32 VDC, 16 amperes, 3000 R.P.M., Ball Bearings. Secondary: 350 volts, 1500 cycles, 7.85 amps. 275 V.A. Single Ph. Built-in frequency control. Specially Priced at \$30.00

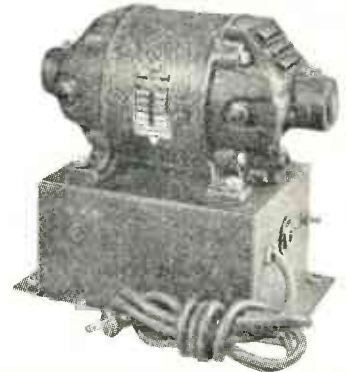

## JANETTE ROTARY CONVERTERS

110 VA. Input: 110 VDC; Output: 110 VAC, single phase, 60 cycles; 3600 speed. With filter for elimination of radio interference. Reliably Rebuilt. Special Price. \$19.95

## CENTURY MOTOR GENERATOR SETS

7.5 KVA; 230 Volts, DC to 115 Volts, AC, single phase, 60 Cycles. Complete with automatic controller and push button station \$445.00

## GENERAL ELECTRIC DC/AC MG SETS

Four Bearing Marine Units; 25 HP 230 VoltsDC coupled to alternator 18.75 KVA; 80% PF; 1800 RPM Ball Bearings. 4 bearing set; marine duty. Brand New. \$545.00

## INDUCTION VOLTAGE REGULATOR

Type IRT, form M. 1.64 KVA, 3 phase, 60 cycles, cont. duty. Outdoor service. Primary: 208 V., 10.5 load amps. Oil-filled. Wgt. 365 lbs. 33 x 17" x 14" \$83.00

## PINCOR ROTARY CONVERTERS

300 VA; Filtered; Brand New. Input: 115 VDC, 4.2 Amp. Output: 220 VAC, 1.36 Amp. SPECIAL PRICE \$38.00

## GENERAL ELECTRIC DC GENERATORS;

Type BD; 1 3/4 K. W. 125/125 Volts. 14 Amps. 1800 Speed Rebuilt. \$65.00

RAYTHEON DISTRIBUTION TRANSFORMERS; .75 KVA; Pri: 220/240; Sec: 110 Volts, single phase, 60 cycles. Brand New \$15.50

## CENTURY MOTOR GENERATOR SETS

Motor: 32 volts, D.C. 5 H.P. sh. wdg. 1300 R.P.M. directly connected to alternator delivering 120 volts, A.C. 3.75 K.V.A. cmb. wdg. Single Ph. 60 cps. Complete with spare parts, controlling field rheostat, Brand New \$335.00

## TAPE WINDERS

These tape winders consist of a motor operative at 110 volts D.C., .6 amperes; 1800 speed. A motor which is separable from the rest of the unit and which can be employed for a multitude of purposes, alone or with the gear reduction box to which it is connected. Motor is shunt wound and the speed thereof is controlled by a built-in rheostat. This makes an invaluable laboratory unit. Special Price \$10.99

MARATHON MOTOR GENERATORS

## MARATHON MOTOR GENERATORS

Input: 110 VDC. Output: 110VAC 1 phase, 60 cy. 500 VA. Marine Type with voltage regulator and frequency controller. Rebuilt \$65.00  
Same unit as above with 32 VDC input and same Output, 300 V.A. \$54.00

## WESTINGHOUSE TRANSFORMERS

399 VA; 115/240 Volts; Brand New. SPECIAL PRICE \$3.35

# APRIL SPECIALS FROM UNITED

## TUBES

3CP1 (Altmr. Se.)	85c	VT-137	3 for \$1.00
31P7	\$2.49	ML-531	3 for \$5.00
5B1P1	\$1.79	923	90c
5B1P4	\$2.95	837	\$1.50
5CP1	\$2.49	852	\$1.95
5CP7-A	\$5.95	1819	3 for \$1.00
5FP7	\$1.49	1825	3 for \$1.00
5GP1	\$2.39	1633	75c
9GP7	\$5.95	1635	\$1.39
VT-25	3 for \$1.00	2051	85c
VT-52	3 for \$1.00	VR-150	75c
VR-105	75c		

## D.C. RELAY AMMETER

7½" D. (R.S.) Standoff type. 0-50 Amps D.C. Single pole to needle normally closed. Pole adjustable over complete scale. Relay terminals on back. Less shunt. Brand New. \$7.95

## WESTON METER RELAY 3"

Model #730 125 to 145 V.D.C. Sensitrol type Relay. Very low current drain. Panel standoff type. All terminals on back. S.P.D.T. Platinum contacts. Needle pole. Brand New—While They Last! \$10.50

## METERS

### A.C. MILLIAMETER 3"

0-1 Ma. Round Bakelite Case. New \$3.95

### D.C. AMMETER 3" ROUND

0-15 Amps Stand-off panel type. Shunt built-in Bakelite Case. New \$2.75

### AMMETER SHUNT

200 Amps. .005 Ohms. Leece-Neville, mounted on Asbestos Base with perforated metal cover. New. 75c each.

## RADAR POWER SUPPLIES

### PP/51-APQ9

80-115 V. 1ϕ 400-2600 Cyc. Complete with 4-5R4GY Tubes. Wt. 40 Lbs. Like New \$5.95

### PP-104/APTS

80-115 V. 1ϕ 400-2600 Cyc. 2-5R4GY. 2-1616 Tubes. Output: 1050 V. @ 150 Ma.; 400 V. @ .5 A. Wt. 40 Lbs. New with Tubes. \$6.95

### PP7/APG2

Uses 5-5U4G, 3-6Y6G, 1-VR-105, 1-VR-150, 1-6SJ7, 1-6AG7, 1-2X2 Tubes. Completely voltage regulated and filtered, with tubes. Wt. Approx. 70 Lbs. New \$14.50

## OUNCER TRANSFORMERS

### W-226262-4

AF Output. Pri. Impedance: 10,000 Ohms. Sec. Impedance: 4000 Ohms, tapped at 250 Ohms. Metal can: 1½" Lg. x 1" O.D. Overall. 10% at 75 Mw. 400 Cyc. 20% at 75 Mw. @ 250 Cyc. Response: 250 to 2500 Cyc. ± 3 DB Glass sealed. New 49¢ each, 3 for \$1.00

### #7254502

Pri. Impedance: 5000 Ohms. Sec. Impedance: 250 Ohms. Size: 1½" Lg. x 1" Overall. Diagram on case. Hermetically sealed. New 39¢ each, 3 for \$1.00

## FRACTIONAL HP MOTOR

24 V.D.C. 5000 R.P.M. 4 leads for Series or shunt connection. Size: 2½" x 1½". Shaft: ¼" x ¾". New \$1.49

## TINSEL CORDS

Two rubber covered colored leads in rubber jacket with lugs on ends. 6½" Long. 100 for \$3.95

## LINE FILTER

Toke Filterette #1166. 250 V.A.C./D.C. 30 Amps. Completely Shld. Heavy terminal at either end. Size: 2" x 2½" x 6". Shpg. Wt. 2½ Lbs. New \$1.75

## MOBILE GENERATOR FILTER

Toke #1107. 6-30 V.D.C. 55 Amps. Completely Shld. with Ferrule connectors for shielding of wiring. Ideal for Aircraft, Marine or Amateur installations. Size: 2½" x 4" x 6½". Shpg. Wt. Approx. 2½ Lbs. New \$1.95

## BC-423 RADAR MODULATOR

A sturdy and beautifully built RF Osc. variable: 125 to 210 Mc. (Approx.) pulse modulated at 4098 C.P.S. Uses 1-955, 2-637, 1-616 and 1-5W4. Operates at 115 V. 60 Cyc. May be modified for T. V. Generator, etc. New with tubes. Shpg. Wt. Approx. 45 Lbs. \$12.50

## CIRCUIT BREAKERS

Heavy duty moulded case. 250 V.A.C. 35 Amp. (G.E. and Trumbell) Double Pole Single Switch, \$1.79 Type M (Sq. "D"). 120-240 V. 20 Amp. Double pole and double switch. New \$1.79

## REMOTE CONTROL CABLES

Used with compass units, MN-26, BC-433G, etc. 20' long. Has spline couplings on both ends. New \$1.95

## WAVE GUIDES

3 Cm. Fine milled and silver plated inside. Slate Gray Exterior. 5' lengths with flange fittings and hardware. New and sealed. Each \$3.35

## CERAMIC WAFER SWITCH

3 P.D.T. Silver plated contacts, wide spaced. ¾" Hub Mounting. Wafer center 1-9/16". Each 59c

## JACKS, TELEPHONE TYPE

(3 Ckt. Fits .205 D. Plug) New. 100 for \$12.75

## SPECIAL VARIABLE CONDENSER

5 gang, 15 to 400 Mmf. per section. Ceramic insulation and ceramic shaft isolates each Rotor. Phosphor bronze rotor contact wipers. ¾" x ¾" shaft. Ball bearings. Gangs individually shielded. Split rotor end plates for tracking. Overall Size: 2½" x 3½" x 7". Cadmium plated. New. Each \$3.75

## H. V. MICA CONDENSERS

Cap. mfd.	Test	Working	Price
.000025	2500 V.	1200 V.	19¢
.00003	5000 V.	2500 V.	23¢
.0005	2500 V.	1200 V.	29¢
.0005		3000 V.	55¢
.001	1000 V.	600 V.	15¢
.002	2500 V.	1200 V.	35¢
.005	5000 V.	2500 V.	45¢
.01	5000 V.	2500 V.	59¢
.01	2500 V.	1200 V.	49¢
.01		800 V. EIT. @	
		3 Mc. 16 Amps.	\$3.75

## PRECISION MICA

500 V. Wkg. Silver 1% Size: ½" x 1"  
1000 Mmf. } 15c ea.  
2000 Mmf. }

## OIL FILLED CONDENSERS

.1 Mfd.	1250 V.D.C.	10 for \$1.29
.1 Mfd.	2000 V.D.C.	3 for \$1.00
.25 Mfd.	2000 V.D.C.	3 for \$1.45
1.0 Mfd.	600 V.D.C.	10 for \$1.69
1.0 Mfd.	1000 V.D.C.	3 for \$1.00
2.0 Mfd.	600 V.D.C.	3 for \$1.00
2.0 Mfd.	5000 V.D.C.	\$5.95
3.0 Mfd.	330 V.A.C.	6 for \$1.75
3.0 Mfd.	2000 V.D.C.	2 for \$3.45
8.0 Mfd.	2500 V.D.C.	\$4.95

## SPECIAL ELECTROLYTICS (METAL CAN)

40-40Mfd	250 V.D.C.	10 for \$4.69
500 Mfd	200 V.D.C.	3 for \$2.69

## RESISTORS

### FERRULE TYPES (Supplied with Mounting Clips)

10 WATT		25 WATT	
1800 Ohms.....	17¢	20 Ohms.....	21¢
2000 Ohms.....	17¢	400 Ohms.....	29¢
3000 Ohms.....	17¢	600 Ohms.....	29¢
3150 Ohms.....	17¢	280 Ohms.....	29¢
		5000 Ohms.....	35¢
		10,000 Ohms.....	39¢
90 WATT		200 WATT	
1.0 Ohms.....	35¢	10,000 Ohms.....	79¢
4.0 Ohms.....	39¢		
6.3 Ohms.....	39¢		
40 Ohms.....	43¢		
2500 Ohms.....	49¢		
3000 Ohms.....	51¢		
3500 Ohms.....	55¢		
4000 Ohms.....	55¢		
5000 Ohms.....	55¢		
6500 Ohms.....	59¢		
7500 Ohms.....	59¢		
10,000 Ohms.....	69¢		

### 5 W. KOOLOHM

14,000 Ohms  
Per 100.....\$6.95

### 10 W. KOOLOHM

500 OHMS  
Per 100.....\$9.75

### WIREWOUND ENAMEL

Ohms Watts  
5000 25 New 31¢  
50,000 100 New 69¢  
75,000 200 New \$1.19

Quantity Prices on Request!! Write for our Latest Flyer!! Quantities Limited!! 25¢ packing charge on orders below \$2.00. Minimum deposit 25% on C.O.D. orders. Prices F.O.B. Chicago. \$25.00 Minimum foreign order acceptable.

# SAVE \$180!

## "KLEEN-AIRE" ELECTRIC AIR CIRCULATOR (PATENTED FILTER) FOR COOL-CLEAN AIR WINTER & SUMMER BRAND NEW

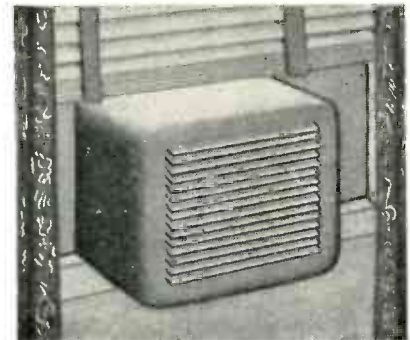

NO DIRT—NO DRAFT—NO NOISE  
CONTINUOUS VARIABLE CONTROL  
PERFECT VENTILATION

Air filtration is assured by use of PATENTED FILTER for ELIMINATING DUST, DIRT, and POLLEN from outdoors.

Ventilates your room with CLEAN, COOL, FILTERED AIR SUMMER or WINTER. Enables you to SUBDUCE outside NOISES by keeping windows closed and to get the amount of air you want, whether calm or stormy.

Easily ADAPTED TO ANY WINDOW without cutting or marring; mounted flush with inside of window for pleasing appearance.

Cabinet is made of HEAVY STEEL with "BAKED ON" BRONZE HAMMERTONE FINISH. Will blend with all home, office, or factory surroundings.

DELIVERS 695 (C.F.M.) CUBIC FEET PER MINUTE IN FREE AIR

A SENSATIONAL BUY! \$44.95  
110V 60 Cycle AC  
MODEL A1  
4 FOR \$175.00 10% U. S. Excise Tax

110 V.D.C. \$59.95 220-250 V.D.C. \$59.95  
TERMS: 20% Deposit, Balance C.O.D., FOB N.Y.C. Rated firms open a/c net 10 days.

# MANUEL KLEIN

74 CORTLANDT STREET  
NEW YORK 7, N. Y. REctor 2-6460

# UNITED SURPLUS MATERIALS

312 S. HALSTED ST. (DEPT. E)

CHICAGO 6, ILLINOIS



**NEW RADAR SPECIALS**

- APS-4 Radomes ..... \$25.00 ea
- J-84/APS-4 Junction Box \$25.00 ea
- AT-38A/APT Antenna APR-4  
\$8.50 ea
- AT-49/APR-4 Antenna ... \$8.50 ea

**AIRCRAFT RADIO EQUIPMENT and TEST SETS**

- 1-96 UHF Sig. Gen. (Recond.) ..... \$200.00
- AN/ARM-1 Test Set for ARC-3 ... 150.00 set
- BC-376-H 75-MC OSC. .... \$95.00
- A-58 Phantom Antenna 100 w, 200 kc—12mc. .... 15.00 ea
- A-98 Phantom Antenna with special R-F Meter, for testing Gibson Girls ... 15.00 ea
- 1-100 Test Set for ARN-7 or 269 Comp. 850.00 set
- BE-67 Test Ind. .... \$15.00
- 1-139 Test Motor for SCR-522. 12.00 ea
- IE-19 Test Set for SCR-522 complete 200.00 set
- TS-10A/APN Altimeter Delay Line 40.00 set
- TS-16/APN Altimeter Test Set 24-v AN/APN-1 ..... 125.00 set
- TS-16X/APN Altimeter Test 12-v AN/APN-1 150.00 set
- TS-80/U Test Meter for AN-ARC-1. 12.00 ea
- 1-86 Test Set ..... 95.00
- RC-54 Test Set for ARC-5 or 274-N Receivers ..... 150.00 set
- RC-55 Test Set for ARC-5 or 274-N Transmitters ..... 250.00 set
- 1-95 UHF Field Strength Ind. (100-150 MC) 35.00
- BC-906 Freq. Meter ..... \$49.00
- Model GP-7 Transmitter, complete. Brand new, all tuning units. .... \$100.00
- W. E. Type 27B Marker Receivers 12-v (complete and reconditioned) ... 150.00 set
- Bendix RTA-1B Transmitter only (recond. L. N.) ..... 500.00 ea

Some of the above Test Sets are one of a kind in stock.

Also in stock: AN/ARC-1, AN/ARC-3, AN/ART-13, BC-348, AN/ARN-7, MN-26, SCR-269-G, RL-41, RL-42, RC-103, ARN-5, 522, 274-N, ARC-5.

**LARGEST DYNAMOTOR LIST AT LOWEST PRICES**

DM-32 (24V) ..... \$ 2.00	DM-18 (MN-26 12V) ..... \$10.00
DY-2/ARR-1 (24V) 3.00	DY-21/ARC-3 ..... 10.00
DM-32-AZ (12V) 12.00	DY-22/ARC-3 ea. 7.00
DM-33 (24V) 5.00	DM-53-A (24V) ea. 5.00
DY-8/ARC-5 (24V) 5.00	DM-53-AZ (12V) ea. 12.00
DM-28 w/rit ..... 6.50	PE-86 w/rit (24V) 3.00
DM-28 less rit ..... 5.00	PE-86-AZ w/rit (12V) 3.00
DM-24 w/rit (12V) 10.00	DY-12/ART-13 w/rit ..... 50.00
DM-24 less rit ..... 8.00	DY-12/ART-13 1/rit ..... 15.00
PE-73 (24V) ..... 12.00	BD-77 (12V) ..... 10.00
D-101 (APN-24V) ea. 10.00	PE-109 Inverter (12V) ..... 50.00
D-101 (APN-1 12V) 5.00	MG-149-H Inverter (24V) 39.00
PE-94-C (522 24V) 5.00	DA-1F BENDIX .. 20.00
PE-98 (522 12V) ..... 20.00	
DA-1A (Bendix TA 21) 25.00	
DA-7A (MN-26 24V) 10.00	
DA-1B (MN-26 12V) 10.00	

ABOVE MATERIAL ALL BRAND NEW IN MANUFACTURERS ORIGINAL BOXES. DELIVERY STOCK, SUBJECT TO OMISSIONS, CORRECTIONS, PRIOR SALE.

LARGE INVENTORY "AN", CANNON, "ARC" AND BREEZE CONNECTORS—SEND US YOUR REQUIREMENTS FOR FAST QUOTATIONS.

**AIRCRAFT RADIO INDUSTRIES**

780 State Street, New Haven, Conn.  
N.Y.C. Office—274 Madison Ave.  
Phone LExington 2-6254

**TEST EQUIPMENT**

X BAND SPECTRUM ANALYZER, 8500-9600 MC, calibrated below cut-off attenuator, calibrated frequency meter, I.F. frequency 20 mc, bandwidth 50 kc, 110-230 V 60-800 cps.

S BAND SPECTRUM ANALYZER, 2700-3400 MC, similar to above.

TS-36/AP X BAND POWER METER.

TS-125/AP S BAND POWER METER.

X BAND BELOW CUT-OFF WAVE GUIDE ATTENUATOR, with calibrated dial and built in line stretcher, type N input connector, output connects to 1/4" x 1" wave guide. .... \$55.00

APR-1 or APR-4 RADAR SEARCH RECEIVER, 30 mc I.F., 2 mc wide.

TUNING UNITS FOR APR-1 or APR-4 RECEIVERS (can be used with any 30 mc amplifier):

- TN-19, range 1000-2000 mc, tuned mixer cavity \$150.00
- TN-54, range 2000-4000 mc, tuned mixer cavity \$150.00

30 MC I. F. STRIP AND 110 VOLT 60 cps POWER SUPPLY, bandwidth 10 mc, complete, new (part of APR-5 Receiver) ..... \$65.00

TS-45A/APM-3 SIGNAL GENERATOR, 9200-9600 mc, 110 V, 60-800 cps

TS-155A/UP S BAND SIGNAL GENERATOR, pulsed, calibrated output, 110 V, 60 cy., NEW

TS-56/AP SLOTTED LINE, slot length 16", tuned probe and meter ..... \$100.00

TS-35/AP X BAND SIGNAL GENERATOR, pulsed, calibrated power meter, frequency meter, 8700-9500 mc

TS-13/AP X BAND SIGNAL GENERATOR, pulsed, calibrated output, 110 V, 60 cycles

WAVEMETER CAVITY, 8500-9600 mc, Transmission Type ..... \$35.00

TPS-51PB/20 S BAND 20 db PAD. .... \$20.00

X BAND PICK-UP HORN ..... \$10.00

X BAND VSWR TEST SET TS-12/AP, complete with linear amplifier, direct reading VSWR meter, slotted waveguide with gear driven traveling probe, matched termination and various adapters, with carrying case, NEW. UNITS I AND II are available separately or together as a test set.

S BAND SIGNAL GENERATOR CAVITY WITH CUT-OFF ATTENUATOR, 2300-2950 mc, 2C49 tube, with modulator chassis. .... \$30.00

HIGH PASS FILTER F-29/SPR-2, cuts off at 1000 mc and below; used for receivers above 1000 mc ..... \$12.00

UPN-1 S BAND BEACON RECEIVER-TRANSMITTER ..... \$75.00

S BAND TEST LOAD TPS-55P/BT, 50 ohms \$8.00

X BAND TEST LOAD TS-108/AP, 150 watts, accessories ..... \$35.00

250 WATT X BAND TEST LOAD, VSWR less than 1.15 between 7 and 10 KMC ..... \$150.00

LAF-1 SIGNAL GENERATOR, 100-600 mc, CW & pulse modulation, calibrated output, good condition, 110 v, 60 cps operation

GENERAL RADIO SIGNAL GENERATOR MODEL 522, 250-1000 mc, good operating condition.

GENERAL RADIO PRECISION WAVEMETER TYPE 724A, range 16 kc to 50 mc, 0.25% accuracy, V.T.V.M. resonance indicator, complete with accessories & carrying case NEW. .... \$175.00

GENERAL RADIO SIGNAL GENERATOR 605-B, good working order ..... \$300.00

GENERAL RADIO VACUUM TUBE BRIDGE, Model 581D ..... \$275.00

FEDERAL RADIO 605-CS, 9 kc to 50 mc SIGNAL GENERATOR (JAN version of G. R. 605) \$350.00

HEWLETT-PACKARD AUDIO SIGNAL GENERATOR 205A ..... \$230.00

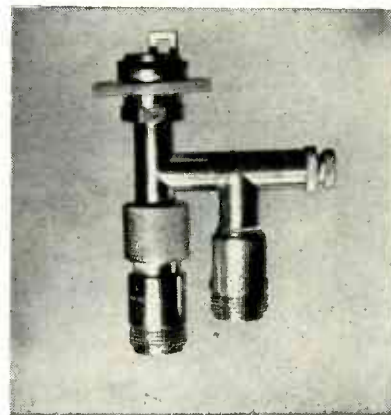

S BAND CRYSTAL MIXER (Illustrated), Variable Oscillator Injection ..... \$12.50

OBU-2 S BAND ECHO BOX ..... \$100.00

TBN-3EV THERMISTOR BRIDGE

S BAND THERMISTOR BRIDGE CU-60 ABU, Part of LZ Radar ..... \$60.00

RADIO RECEIVER BC-96772, 18-160 mc, 3 bands, FM/AM, 110 V, 60 cps ..... \$200.00

MEASUREMENTS 78E, 50-75 mc, calibrated output ..... \$100.00

FERRIS MODEL 22A SIGNAL GENERATOR, 85 kc to 25 mc. Output 2 microvolts to 1 volt, modulation variable, good working order \$175.00

FERRIS MODEL 10B SIGNAL GENERATOR, 85 kc to 25 mc, calibrated output, good working order ..... \$100.00

FERRIS 18 C SIGNAL GENERATOR, 5-175 mc, calibrated output, good working order ..... \$250.00

STANDARD SIGNAL GENERATOR MEASUREMENTS 65B, 100 kc to 30 mc, 1-2,000,000 microvolts, good working order ..... \$400.00

LABORATORY RECTIFIER, SYLVANIA 541-A, 3500 volts at 2 amperes DC output.

LB-3 LIMIT BRIDGE, Industrial Products \$60.00

SIGNAL GENERATOR, 1-72-K, 100 kc to 32 mc, output not calibrated, 110 V, 60 cps. .... \$35.00

AUDIO OSCILLATOR, HICKOK 198, RC tuned, 20-20000 cps ..... \$45.00

TEST SET TS-278/AP FOR AN/APS-13, synchronized, delayed pulse signal generator, 400-430 mc, calibrated waveguide below cutoff attenuator, synchronized marker generator, 115 V, 80 cps, NEW, COMPLETE. .... \$160.00

CLOUGH, BREngle RESISTANCE CAPACITY BRIDGE, model 230A, new ..... \$50.00

FIXED ATTENUATOR PADS, 20 db + 0 — 2 db, DC-1200 mc, 50 ohms, VSWR 1.3 or less, 2 watts average power ..... \$30.00

WAVEGUIDE BELOW CUT-OFF ATTENUATOR, type N connectors, rack and pinion drive, attenuation variable 120 decibels, calibrated 20-120 db, frequency range 300-2000 mc. .... \$32.00

WAVEGUIDE BELOW CUT-OFF ATTENUATOR, similar to above except upper frequency limit is 3300 mc ..... \$32.00

WAVEGUIDE BELOW CUT-OFF ATTENUATOR, same as above except input is matched in range of 2200-3300 mc, VSWR less than 1-2. .... \$54.00

PULSE INPUT TRANSFORMER, permalloy core, 50 to 4000 kc impedance ratio 120 to 2350 ohms \$3.00

PULSE TRANSFORMER, UTAH 9280 ..... \$1.50

PULSE TRANSFORMER, 132-AWF ..... \$6.00

PULSE TRANSFORMER, GE 68G, 828G-1. .... \$5.00

TS-10/AP CALIBRATED DELAY FOR APN-1. .... \$25.00

TS-203/AP CALIBRATED SELSYN ..... \$10.00

UG-27/U TYPE N RIGHT ANGLE ADAPTERS 10 for \$5.00; 1000 for \$250.00

SD-3 SHIPBOARD RADAR, New and complete with test equipment. .... \$1650.00

SQ RADAR, used but in good working order, complete with antenna, control unit. .... \$650.00

SN RADAR, used, good working order, complete ..... \$550.00

HYPERSIL CORE CHOKE, 1 Henry, Westinghouse L-422031 or L-422032 ..... \$3.00

PULSE FORMING NETWORK, 20 kv, .92 microsecond, 50 ohms, 800 p.p.s. .... \$40.00

ANCHOR SCREWS from AB26CR Mast Equipment ..... \$2.00 each

**ELECTRO IMPULSE LABORATORY**

P. O. Box 250 Eatontown 3-0768 Red Bank, N. J.

# NEW YORK'S RADIO TUBE EXCHANGE

TYPE	PRICE	TYPE	PRICE	TYPE	PRICE	TYPE	PRICE	TYPE	PRICE
0A4G	\$7.2	4B30	1.75	250TH	19.25	720DY	45.00	975A	12.50
C1B	3.95	4C21	1.25	250TL	15.00	721A	2.40	991	.25
1B22	5.95	4C27	2.95	250R	5.95	722A	3.95	CK1005	.35
1B23	8.95	4C30	1.25	HK253	6.95	723A	6.95	CK1006	.25
1B24	4.95	4C35	19.95	274B	1.75	723A/B	10.95	1280	.99
1B26	2.95	4J25	95.00	274A	3.95	724A	2.95	1622	.59
1B35	19.95	4J26	95.00	CE303	3.95	724B	3.95	1611	1.50
1B38	32.50	4J31	95.00	304TH	3.95	725A	12.95	1613	.75
1J22	7.95	4J35	195.00	304TL	1.25	726A	9.95	1616	1.10
1B56	45.00	4J38	95.00	307A	4.25	726B	19.95	1619	.50
1B60	45.00	4J40	195.00	310A	4.50	726C	36.00	1624	.99
1N21	.85	4J52	350.00	316A	.69	728AY	45.00	1625	.45
1N21A	.95	5BP1	2.75	350A	2.40	801A	.69	1626	.45
1N21B	1.50	5BP4	3.95	350B	1.80	802	4.50	1629	.45
1N23	.85	5C21	9.95	368AS	2.40	803	4.50	1631	.89
1N23A	.95	5CP1	1.95	371B	.99	804	10.95	1635	1.70
1S21	3.75	5D21	19.95	388A	1.80	805	4.95	1641	1.10
2A1	3.50	5CB	9.95	393A	4.95	807	1.35	1851	1.00
2C23	.75	5FP7	1.95	394A	4.95	808	2.75	1852	.99
2C33	1.95	5J1	45.00	417A	12.95	809	2.75	1853	.90
2C40	3.95	5J2	15.95	434A	2.75	810	7.50	2050	.99
2C43	12.50	5J2A	25.00	450TH	17.50	811	2.11	2051	.55
2C44	1.25	6A	7.95	450TL	37.50	812	2.75	8012A	3.95
2C51	7.50	6AC7	.90	446A	.90	813	7.95	8013A	2.75
2D21	1.08	6AC7W	1.50	446B	1.80	814	2.95	8014A	25.00
2J21	9.95	6AK5	1.6	WL468	5.95	815	1.50	8016	1.25
2J22	6.95	6C21	19.95	WL469	2.75	827R	90.00	852	9.95
2J26	8.75	6F4	5.95	WL525	3.95	829B	7.50	860	3.75
2J27	9.75	6J4	4.95	527	7.95	832	3.95	861	19.95
2J31	9.75	6-8	.95	WL530	12.95	832A	4.50	866A	1.15
2J32	12.95	6SU7CT	1.25	WL531	7.95	834	7.50	869B	29.95
2J36	105.00	7BP7	4.95	WL532	2.95	836	1.10	872A	2.75
2J38	7.95	7DP4	12.50	53	39.95	837	1.95	874	1.95
2J40	25.00	10Y	.59	WL535	7.75	838	3.75	876	.75
2J42	150.00	15E	1.50	WL538	1.25	845	4.50	878	2.25
2J49	24.50	15R	1.00	GI570	1.25	849	19.95	8019	1.75
2J50	24.50	RX21	2.50	575A	12.50	851	19.95	8020	2.95
2J55	55.00	5C22	45.00	579B	5.95	884	1.25	8021	1.75
2J61	45.00	6C21	35.00	700A to B	19.50	885	1.25	8022	1.00
2J62	45.00	RK72	.95	701A	3.95	931A	3.95	8025	3.75
2K25	19.95	RK73	.95	703A	2.40	954	.45	9001	.55
2K28	19.95	OK77	249.00	705A	.75	955	.45	9002	.35
2K29	24.95	OK47	55.00	707A	6.95	956	.45	9003	.35
2K44 on Request		OK59	59.00	707B	9.95	957	.25	9004	.45
2K45 on Request		OK61	49.50	710A	1.25	958A	.55	9006	.25
2X2A	.69	RK39	2.25	714AY	4.95	959	.75		
2V3G	.99	RK49	2.40	715A	6.95				
2Y48	29.95	VR53	.29	715B	9.95				
3A4	.75	VR95	.45	715C	24.95				
3A5	.95	100TH	10.95	717A					
3AP1	4.95	VR105	.79	720AY	45.00				
3BP1	3.95	F123A	8.95	720BY	45.00				
3B24	1.50	VR150	.63	720CY	45.00				
3C23	3.95	VT98	39.95						
3C24	.95	X99	.75						
3C31	.95	203A	3.95						
3C45	13.95	211	.75						
3DP1A	3.25	217C	6.95						
3E29	7.50	242C	7.50						
3J31	59.95	249C	3.75						
4A1	.95								

## LIST OF TEST EQUIPMENT

### Micro-Wave Test Equipment

- K Band Spectrum Analyzer
- X Band Spectrum Analyzer
- X Band Signal Generator Types
  - TS 13
  - TS 16AA
  - TS 33
  - TS 35
  - TS 35
- X Band Magic T
- X Band Crystal Tunable Mounts
- RF 4 Echo Box S Band
- S Band Signal Generators PE 102, BC 1277/60ABQI
- S Band Power Meter

### Oscilloscopes

- BC 1287A
- Coscor Two Beam

### Standard Broadcast and Short Wave Equipment

- TS 69
- Ferris 20B Microvoluter
- Rider 182C Chanalist
- Rider S.W. Adaptor for Chanalist
- RCA Audio Chanalist
- Measurement Corp 65 B Signal Gener.
- Boonton 160A Q Meter
- New Boxed Motor Generator Sets delivering 1200 W. at 480 cy. and 100 W. 28 V.D.C. from 110 v., 60 cy., to operate on the ground aircraft equipment.

### Meters

- TS 15/AP Gauss Meter
- General Radio Tube Voltmeter Type 728A to 3000 volt
- Airradio Millivoltmeter 0-2 Millivolt
- Model 617-F Shaltross, Percent Limit Bridge
- Model 40 Pyrometer, Elematic Equipment Co.
- Light Spot Galvanometers, General Scientific Co.
- Microammeter Rollers 0-10 Microamp.

### Radar Sets

- APS3 Complete and Parts
- APS4 Complete and Parts
- SCR 284

350A is a long life WE807  
 350B is a long life WE6LG  
 WE701A can be used for a Super 813

\$10 Minimum Order

ATTENTION  
 PURCHASING AGENTS  
 SCHOOLS, MFRS. ETC.  
 We buy your Surplus Inventories for  
 CASH in Tubes, Parts and Test  
 Equipment.



PHONE WORTH 4-8262

135 LIBERTY ST. NEW YORK 6, N.Y.

### TRANSMITTERS

#### NEW OR NEAR NEW ONLY

BC-610 Hallcrafters. 2.0-18.0 mcs. 450 watts CW 350 watts phone. Antenna tuner & speech amplifier, cables, manuals, complete. Wt: 446 lbs net.

BC-365 Federal Tel. & Tel. 150 to 550 Kcs. 350 watts CW, for Radio Range or carrier communication. Complete. Wt: 629 lbs net.

BC-325 Federal Tel. & Tel., 1.5-18.0 Mcs. 400 W. phone 100 W. CW, complete with remote control. Wt: 900 lbs net.

TDE Westinghouse Mfg. 300 to 18,100 Kcs., 125 W. A1; 35 W. A2 A3; for naval or shore use. Complete in several input voltages. Wt: 672 lbs net.

Western Electric WE-34A; R.C.A. ET-8019; Westinghouse TCE; and others.

### RECEIVER-TRANSMITTER COMBINATIONS

SCR-508/528 FM at 35 Watts output; 20.0-27.9 Mcs., complete with receiver and transmitter, dynamotors, control boxes, crystals, antennas.

SCR-608/628 as above, except for frequency of 27.0-38.9 Mcs.

TCS Mfged by Collins, 40/20 W. Phone & CV for 12 V. DC, 1.5 to 12.0 Mcs. with all accessories.

AVT/R/A Mged by RCA, 6-10 Watts phone and CW 2300 to 6700 Kcs. Small compact for 6 & 12 V.D.C. NEW & COMPLETE with power supply, mike, key & antenna.

Complete bulletins on request.

### RADIOTELEPHONES

#### Brand New!

We have just acquired a very large stock of radio telephone units all BRAND NEW and COMPLETE in 5, 25, 50 and 75 Watt models by Harvey-Wells, Jefferson Travis, Hallcrafters and R.C.A. Descriptive data on request.

### RADAR SEARCH RECEIVERS ARD-2 80 TO 3000 MCS.

Here is a complete unit selling for less than other precision search receiver components alone. Packed in original cases with 110 V AC power supply of 60-2600 cycles. The P.R.R. is from 50 to 8000 cps. Includes 2 Antennas, detector, all tubes, cables, 2 manuals, test oscillator and spares. Excellent for TV manufacturers and researchers. BRAND NEW. Each \$175.

Other Radar units and accessories in stock: New SN portable units, APR-1 etc.

### WALKIE-TALKIES HANDY TALKIES

Many types to choose from in new and complete condition and guaranteed. Bulletins on request.

MOBILE EQUIPMENT—for 6 Volt DC operation, in 30 to 40 Megacycle band. Receivers and transmitters mfged by RCA, LINK, Motorola, NEW.

## BY POPULAR DEMAND

MIRROR — front surface aluminized on optical glass 1 3/16" diameter 3/32" thick .....\$5.00

PRECISION LEVEL — interior ground tube level with 4 adjusting screws. Overall length 1 1/2" diam. 15/32". One end with shoulder 1/2" diam. \$.85

DELCO BLOWER — strocco type D.C. Flange diameter 3 1/2" blade 3-3/16" RPM @ 12 volts 3400 RPM @ 6 volts 1600 .....\$3.95

SELENIUM RECTIFIERS — G.E. model 6RS 6PB3 maximum A.C. volts 56 D.C. amps. 0.150.....\$1.35

CIRCUIT BREAKER — 10 amp 30 volt D.C. C-H. Cat. #8751K4...\$1.10

GLASS VIAL — to use as a permanent level on equipment .....\$1.00

RELAYS — G.E. Type CR2791-B109M3 Res. 170 OHMS 24 Volts D.C. SPDT...\$.69  
 Cutler Hammer #506 Relay Bull. #6001 SPNO .....\$1.75

TELECHIRON B-3—4 watt Synchronous Motors 5/6 RPM on 50 cycle 1 RPM on 60 cycles .....\$3.50

DETROIT THERMOSTATIC EXPANSION VALVES #674-494 3-8" Inlet; 1-2" S A E Outlet; 7-32" Orifice for use with FREON, Maximum Operation 55 lbs. ....\$4.50

WATTHOUR METER SINGLE PHASE — G.E. type I-16 two wire 5 amp. 115 volt 60 cycle .....\$5.75

SEND FOR FREE BULLETIN



Cable: COMMUNIDEV  
**COMMUNICATION DEVICES CO.**  
 2331 TWELFTH AVENUE  
 NEW YORK 27, N. Y.



**SORRY!**

We'd like to advertise our warehouse full of electronic items. But that would fill every page in this magazine! Here are only 3 of 10,000 items we carry.

**PLEASE!**

Write us about your needs. Chances are 50 to 1 we've got what you want. If we haven't—we can get it! It'll pay you to quizz us by mail!



**RAYTHEON  
RECTICHARGER  
W-3155**

Supply current at a constant voltage and supplies current to a storage battery, providing an automatic AC-DC power system; No moving parts; No adjustments; Life of the battery increases as much as 40%; Eliminates voltage variations. 11/12 cells, 22-24 volts at 3 amp. output; Input 95-130 volts, 60 cycles; Weight \$45.00 180 pounds.

**1-222-A RF  
SIGNAL GENERATOR**

2 hands cover from 8 to 15 Mc., and 150 to 230 Mc. Can use up to the 3-harmonic; 110 V. 60 cycles built in power supply. New.

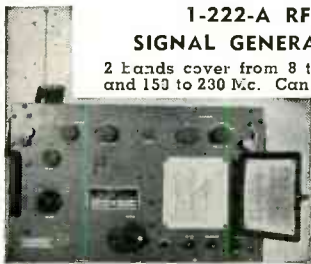

\$125.00



**VARIAC TRANSTAT AMERTRAN**

Input 0-115 V., 50-60 cycle; output 115 V 100 amps. 11.5 Kva. Excellent condition \$75.00

**COLUMBIA ELECTRONICS Ltd.**

524 S. San Pedro St.  
Los Angeles 13, Calif.

Cable Address: COLECT

25% deposit with order. Balance C.O.D.  
All items subject to prior sale

**BUY NOW!!**

**POWER SUPPLY KITS  
24 to 28 VDC Filtered**

Designed for continuous duty ground operation and bench testing of aircraft equipment, these kits provide a reliable means of obtaining a source of low ripple 24 VDC, from a 115 VAC 60 cycle line. Full wave bridge Selenium Rectifiers insure instantaneous and efficient operation. Adjustment of the DC output voltage is accomplished by transformer primary taps. Ripple is limited to within 2% of the average DC output by choke-input filters.

Kit	Amperes DC	Net Price
242	2.0	\$16.39
245	5.0	22.39
2410	10.0	47.44
2420	20.0	79.44

Write for descriptive Bulletin No. 201

**DC POWER  
SUPPLY**

Limited quantity — Gov't Surplus Ready to operate. Full wave bridge copper-oxide rectifier heavy duty multi-tapped transformer.

Input: 85/95/105/115/VAC 50/60 cps  
Output: 2.5/24/28/32/36 VDC at 5 amperes, unfiltered

For wall or bench mounting. Overall dimen. 9" x 8 1/2" x 8 3/4" high. Shpg. wt. 30 lbs. Tested and guaranteed... \$38.00  
Filter Kit, 2% ripple... 6.65

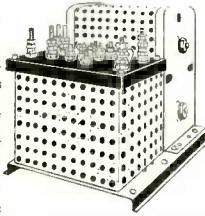

**DIEHL MOTOR**

Fan duty, brushless induction type (no TV interference). For 115 VAC 60 cycles 46 watts 1800 RPM. Shaft 1/4" diam. 1" long. Noiseless ball-bearings— heavy cast construction. Brand new \$4.50

**RECTIFIER KIT NO. 612-10**

6 and 12 VDC at 10 Amperes  
This unit will deliver unfiltered direct current for operation of motors, dynamos, solenoids, relays and similar equipment. Employs full wave Selenium Rectifier and heavy-duty primary tapped transformer. The two output voltages can be used simultaneously and may be adjusted between 6.7-7.6 VDC and 13-15 VDC, under full load. For 115 VAC 60 cycle input. With schematic diagram and instructions. Shpg. wt., 12 lbs. \$15.95

**Filter Kits for #612-10**

1 Section choke input, 10% ripple... \$9.64  
2 Section choke input, 2% ripple... 19.28

**D-C PANEL METERS**

Attractive, rugged, and reasonably priced. Moving vane solenoid type with accuracy within 5%.

0-6 Amperes D-C Any range  
0-12 Amperes D-C \$2.49 each  
0-15 Volts D-C

Minimum order \$3.00. No C.O.D.'s. Add 10% for Prepaid Parcel Post and Handling. Terms: Net 10 days in the presence of approved credit.

All prices subject to change without notice. Prices and Delivery F.O.B. our NYC Warehouse. All merchandise subject to prior sale.

**WESTERN ELECTRIC  
BLOWER**

#KS5881 — Brand New — Heavy Duty Sirocco type blower, capacitor start, 1/40 H.P. 3400 RPM 115 VAC 60 cycles. Displaces 84 C.F.M. Extremely quiet operation. Opening 2 3/4", overall size 7 1/2" long, 6" diam. Moisture and fungus resistant. With capacitor. Shpg. Wt. 15 lbs. Quantity limited \$13.95

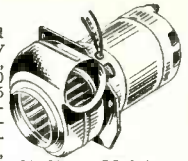

**VACUUM CAPACITORS**

Standard Brands

12 Mmfd.	20 KV	\$4.95
50 Mmfd.	32 KV	5.95

Overall length: 6 1/2", Diam. 2-3/16". Terminal Diam: 3/8". Shpg. Wt 2 lbs.



**EDISON THERMO TIME DELAY RELAY**

Heater voltage 115 V. Norm. open SPST contacts. 15-30 sec. delay. Contact rating 115 V. 3A., 440 V. 2A. Size 3 3/4" x 1 3/4" diam. Standard 4 prong tube base 98c ea.

**KLIXON 40 SECOND  
DELAY SWITCH**

Heater operates on 115 VAC or DC. Contacts SPST—rated at 30 A., 115V, or 20 A. 220 V. plus auxiliary contacts for lighter loads. Each... \$2.49

**PILOT LIGHT ASSEMBLIES**

Aircraft type, panel mounting, amber jewel only. Knurled rim controls "Dim-Bright." Bakelite and aluminum construction. Bulb replaceable from front panel. For single contact bayonet bulbs. T-3/4" or G-3/4" size. Dimensions: 2 1/4" overall length, 3 1/4" diameter, 3/8" panel mtg. hole. IMMEDIATE DELIVERY — 500 to carton, nested, \$50.00 per carton. Prices on larger quantities on request.



**SILVER CERAMIC TRIMMERS**

820-Z	5-20 Mmfd Zero Temp.	24c
822-N	5-20 Mmfd Neg. 300	24c
822-AZ	4.5-25 Mmfd Zero Temp.	24c
823-AN	20-125 Mmfd Neg. 650.	33c

**SELENIUM  
RECTIFIER CATALOG**

Write for our Catalog No. 719 which lists Selenium Rectifiers, associated transformers, condensers and filter chokes.

**Opad-Green**  
COMPANY  
71-2 Warren St. New York 7, N. Y.  
Phone: BEekman 3-7385-6

**D.C. MICROAMMETERS**

0-200 ua 3" sq. G.E. DO 50	\$ 8.00
0-100 ua 3" sq. G.E. DO 50	10.00
0-50 ua 3" sq. G.E. DO 50	12.00

**R.F. MILLIAMMETERS**

0-115 Ma 3 1/2" Weston 425	\$12.00
0-100 Ma 3 1/2" Weston 425	12.00

**PRECISION  
PORTABLE INSTRUMENTS**

Single or multi-range

D.C. Microammeters, from 5 ua full scale  
Thermo-couple Milliammeters, from 1.5 Ma.  
Thermo-couple voltmeters.

Precision Electrical Instrument Co.  
146 Grand Street New York 13, N. Y.

The  
**"KELLOGG DEHYDRATOR"**

An all purpose self-reactivating dehydrating unit. To be used for removing moisture from gases. Numerous applications in the fields of Physics, Electronics and Chemistry. Dual insulated tanks with themostatically controlled heating elements. Complete with 20 lbs. of Silica gel, heating elements, shut-off and safety valves. \$62.50  
F.O.B. N. Y.

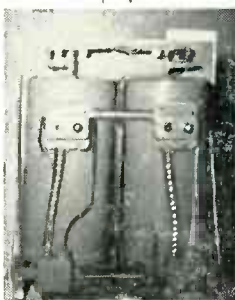

**INTERSTATE Appliance Co., Inc.**

Dept. KD, 600 Broadway, NEW YORK 12, N. Y.

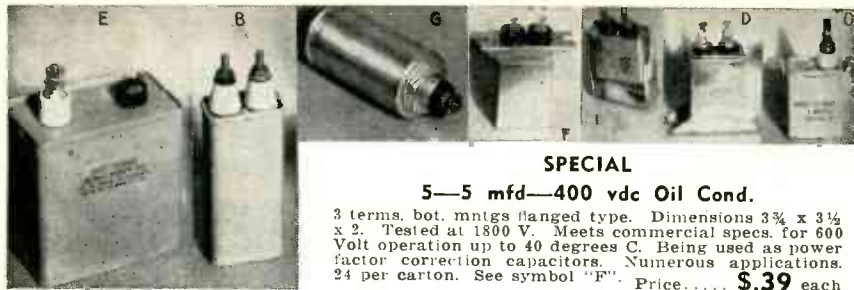

**SPECIAL**

**5—5 mfd—400 vdc Oil Cond.**

3 terms, bot. mntgs flanged type. Dimensions 3 3/4 x 3 1/4 x 2. Tested at 1800 V. Meets commercial specs. for 600 Volt operation up to 40 degrees C. Being used as power factor correction capacitors. Numerous applications. 24 per carton. See symbol "F". Price..... **\$ .39** each

**OIL CONDENSERS—NEW**

Symbol	Cap.	Voltage	Type	Price
B	.005-.005-01	10KV	(4 Term) #26F344	2.50
E	.007	1,000V	Rev. bkt.	.88
I	.03	16KV	#26F380	3.00
O	1	1,600V		.22
B	1	2,000V		.38
F	1	3,500V	#2516CB	.55
G	1	5,000V		.65
B	1	7,000V	#25F744	1.00
B	1	7,000V	Can 1 Term.	.90
B	1	7,500V	#23F447	1.10
B	1	15,000V	#25F572	4.25
B	2	10,000V	#25F433	4.25
B	.25	3,000V		1.15
B	.25	6,000V	#25F659	1.25
B	.25	20,000V		16.95
B	.5	10,000V	#14F267	4.75
D	.5	400V	#416MCT	.12
D	.5	500V	#9CE6A3	.14
B	.5-.5	600V	#609MR	.20
B	.5	2,000V		.75
B	.5	3,000V	CP70E1EL504	1.15
B	.75	1,000V	PC567	.17
D	1	500V	#23F266	.18
F	1	500V	#23F225	.18
F	1	600V	CP6881-EF105V	.24
B	1	10,000V	#GE14F267	9.95
B	1	15,000V		15.75
D	1.25-1.25	7,500V	23F360	4.75
D	2	600V	TLA Type	.25
G	2	1,000V	TLA Type	.40
B	2	1,000V		.49
B	2	2,500V	Bkts	2.15
B	2	4,000V	#23F47G2	3.65
G	3	600V	Can	.25
B	3	4,000V		4.50
B	4	400V	WE-D161659	3.00
B	4	600V	26F317	.50
B	5	600V		.55
B	10	600V		.85
B	15	1,000V	TJH10150	2.15
B	80	4,000V	14F204	22.00

**CERAMICON CONDS.**

10, 56, 100 & 250 mmfd.....	\$5.00 per "C"
1000 & 5000 mmfd.....	\$6.00 per "C"

**TUBULAR OIL FILLED CONDS.**

.02 & .03 mfd-400V.....	\$6.00 per "C"
.1 mfd-1000 V.....	\$8.00 per "C"

**POTENTIOMETERS**

Type	Shank and Shaft	Ohm
Wire Wound	3/8 x 1/2(S)	5,000
Wire Wound	3/8 x 1/2(S)	10,000
Wire Wound	3/8 x 1/4(S)	50,000
Wire Wound	3/8 x 1/4(S)	50,000
Wire Wound	3/8 x 1/4(R)	10,000
Carbon	3/8 x 1/0(R)	10,000
Carbon	7/16 x 3/0(F)	10,000

See Feb. issue for Type "J" Pots.

**TUBES**

3C24.....	.24	872A.....	1.00	954.....	.15
12CB.....	.35	838.....	2.25	1616.....	.50

**COAXIAL CONNECTORS**

UG-10/U.....	.85	UG-30/U.....	.90	UG-201/U.....	.85
UG-12/U.....	.59	UG-30/U.....	.90	UG-245/U.....	.59
UG-21/U.....	.59	Spectral.....	.90	UG-266/U.....	.59
UG-22/U.....	.59	UG-58/U.....	.56	PL54.....	.10
UG-23/U.....	.59	UG-59/U.....	.59	PL81.....	.40
UG-24/U.....	.59	UG-83/U.....	.59	83-1R.....	.28
UG-25/U.....	.59	UG-86/U.....	.98	83-1SP.....	.24
UG-27/U.....	.59	UG-167/U.....	1.75	83-1SPN.....	.24
UG-29/U.....	.65	UG-190/U.....	.85		

AN-3102-148-5P.....	.25
AN-3102-148-2P.....	.25
RC-10066-201P.....	.25

**MISCELLANEOUS**

Trans. 115 V. 60 cy. 700 V. 70 Ma. Ct. Fil. 5 V. 3a.; 6.3 V. 3a. Ct. ....	\$2.00
Trans. Jcf. #240-151 Pwr. Cir. type (Double Wound) 5 KVA. 50/60 cy. 230 V. Prim. 115 V. Sec. ....	\$10.00
Jack midget closed cir. ....	\$ .15
Cond. 8-8 mfd-450 V. Can upright chassis mntg. ....	\$ .25
Cond. Trimmer 5 plate 3/4" x 1/2". Ceramic base ....	\$ .20
Meter R.F.A. Thermo coupled type 0-4 scale	\$3.00
Socket, octal bakelite. ....	\$ .05
Mu-Switch, SPDT Lever type. ....	\$ .30
Resistor 1/2 w 5% 47,000 ohms	\$1.50 per "C"
Resistor 50 Meg. Lugs. ....	\$ .08

**GOVT SURPLUS**

WE CARRY A LARGE AND VARIED INVENTORY WHICH INCLUDES:

- AIR CONNec-TORS
- CABLE
- CAPACITORS
- CHOKES
- CIRCUIT BREAKERS
- COAX-CON-NECTORS
- COILS
- CORDS
- CRYSTALS
- DELAY LINES
- FILTERS
- FUSES
- INVERTERS
- KLYSTRONS
- MAGNETRONS
- MAGNETS
- MICROPHONES
- METERS
- MOTORS
- POTENTIOME-TERS
- POWER SUP-PLIES
- PROJECTION LAMPS
- SELSYNS
- SCOPE ACCES-SORIES
- SHOCK MOUNTS
- SOCKETTS
- SWITCHES
- TELEPHONE EQUIP.
- TEST EQUIP-MENT
- TRANS-FORMERS
- TRANSMIT-TERS
- TUBES
- WAVEGUIDE
- WAVEMETERS
- WIRE

A PENNY POST-CARD WILL PUT YOUR NAME ON OUR MAILING LIST.

**DUBIN**

**ELECTRONICS CO. INC.**

Dept. 103-02 NORTHERN BLVD., CORONA NEW YORK E-450 Telephones: Hickory 6-3066-7-8

**MOLDED PAPER CONDS.**

.004, .01, .03, .05 mfd @ 400V..	\$4.00 per "C"
.006, .01, .03, .05 mfd @ 600V..	\$3.00 per "C"

**MICA CONDS.**

30, 39, 75, 100, 140, 150, 200, 230, 240, 250, 300, 350, 400, 500, 1000, 1250, 1300, 150, 3000, 3800, 4700, 5000, 6000 and 10,000 mmfd @ 500V. \$3.50 per "C". Kit of 100 @ \$2.95.

**SILVER MICA CONDS.**

10, 20, 30, 50, 100, 120, 140, 150, 200, 240, 250, 300, 345, 400, 500, 670, 1000, 1800, 2000 and 2500 mmfd @ 500V. \$7.00 per "C". Kit of 100 @ \$5.95.

**MONMOUTH RADIO LABORATORIES**

BOX 159

OAKHURST, N. J.

**GRAIN OF WHEAT LAMPS**



Used for illuminating meters, compass dials, airplane instruments, etc. Soldering iron removes lamp from base to use in models, doll houses, miniature trains, Xmas trees, etc.

Mazda G.E. 323 doz. \$1.50 3V-19.A

**MARKTIME**

5 HOUR SWITCH



A 10 amp. timing device. Pointer moves back to zero after time elapses. Ideal for shutting off radios and TV sets when you go to bed. Limited supply at this special PRICE..... **\$3.90**

Also available in 15 min.-30 min.-1 hr. at \$8.50

**ISOLATION TRANSFORMER**

Nat. known Mfrs. 50 watt 2 windings, 115 V. to 115 V. 60 cy. Ideal to prevent shocks from small radios and medical and electronic devices. Shipping Weight 5 lbs. Other sizes and 220-110 in stock. **\$1.95**

**GONIOMETER** CFT-47263 CFT-47372

Kilowatt Demand Meter Totalizer containing heavy-duty TELECHRON B-7, 1 RPM motor and hundreds of watch size gears, clutches, springs, etc. Shipping weight 2 lbs. 5 for \$10.00 **\$2.50** \$5.00 to \$17.50

**RADAR MAGNETS** Write for Sizes and Weights. RCA 930 PHOTO TUBE..... **\$1.25** 5 for \$5.00

MAGNESYN Pioneer CL-8..... \$1.50 IN 23..... \$1.75 CRYSTAL DIODE IN 34..... \$1.35

INSTANT REVERSIBLE 50 RPM HOLTZER-CABOT MOTOR 110 V.A.C..... \$17.50 SMALL 12V. DC-40 OHM RELAY..... 5 for \$1.00 Sample 50c

ANT. KNIFE SWITCH S.P.D.T. 30 AMP..... 95c ALLIANCE OR RUSSELL 110V AC MOTOR. \$1.65; 3 for \$5.00

We are Authorized Wholesalers for Micro Switch Corp. and carry the largest stock of Allen-Bradley Solenoids, Potter & Broomfield Relays, Guardian Electric Co. Solenoids and Relays and Haydon Clock Motors in all speeds. Electric Counters.

EST. 1923 **BLAN** EST. 1923

Experimenters and Inventors Supplies 64 Dey St., New York 7, N. Y.



**VAST STOCK** GUARANTEED—IMMEDIATE DELIVERY Write us your needs for our quote

**AN CONNECTORS**

- AN 3106-40-95 69¢ ea
- AN 3108-36-155 69¢ ea
- AN 3108-18-1P 39¢ ea
- AN-3108-12S-3S 25¢ ea.
- AN-3102-10S-2P 20¢ ea.
- AN-3106-10S-2S 18¢ ea.

And many others.

Write for Our Quote

**SOLENOIDS**

G. E. CR9533K100A2 240 ohm 24 VDC DPST N.C. & SPST n.o. 2 switchettes, Extra Long throw #R132... \$8.40 HART M568A CAT # 694R19 75 ohm 24 VDC 200 amp. cont. SPST n.o. #R127A..... \$1.75



**SINE - COSINE - SQUARE - WAVE POTEN-TIOMETER V.E. CO# D169100** for very low freq. s w e e p circuits \$9.95 ea.

**S.S. WHITE DENTAL LAB RESISTORS** 1K, 4K, 60K, 100K, 500K. All 1 Watt \$7.50/C



**H-F TIE POST** LOW-LOSS BAKELITE INSULATION \$7.50/C \$67.00/M

**LARGE STOCKS OF** APC's Binding Posts Hardware Fuses Knobs Relays Resistors Shock-Sockets Mounts Sockets Spaghetti Switches Trans-formers Tubes Write Us Your Needs for Immediate Quote

Min. Order \$2.50

**Universal/general corp.** Prices Not FOB Our Plant Walker 5-9642 365 Canal St., New York 13, N. Y.



# COMMUNICATION EQUIPMENT



Line Terminal and composite panel W.E. Co. X-61823C for terminating composited open wire and cable circuits using 1000 cycle signaling.

Teletype Model 19—Page—Sending—Receiving & Tape Perforating Set.



"Speech plus Duplex Telegraph Terminals" derives carrier telegraph circuit from telephone circuit while retaining voice circuit.



W. E. Co. Type 506B Cordless Monitor Telephone Switchboard.

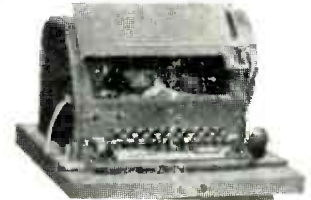

Teletype Model 14—Sending—Receiving Typing Reperforator Set.

- TELEPHONE CARRIER ● TELETYPEWRITERS
- TELEGRAPH CARRIER ● TELEPHONE SWITCHBOARDS
- SPEECH PLUS DUPLEX TELEGRAPH TERMINALS

CABLE - MASTELRAD

## MASPETH TELEPHONE & RADIO CORPORATION

142 ASHLAND PLACE BROOKLYN 1, NEW YORK MAIN 4-2982—TWX: N. Y. 2-1123

### SOUNDTRONICS SPECIALS

**RA 38 POWER SUPPLY COMPONENTS** Consisting of original plate trans. Four Fil. trans., one reactor. one cap. Output 15 KV. @ 500 MA. .... \$185.00

6 V. @ 12 amp. Trans. 115 V @ 60 cy. imp. Open Frame 2 1/2" x 3" x 3 1/2" ..... 1.65

3 C. M. FLEX WAVE GUIDE SECTION 2" long sq. to sq. flange ..... \$1.75

**FERRIS PREC. HI-FREQ. 5 STEP ATTN.**  
1. 10, 100, 1 K & 10 K ..... \$6.75

**REMOTE CONTROL M2 AMPLIFIER** 115 V. 60 cy. Input 2 channels of Class B amp. used for servo control less tubes ..... \$8.75



**14 PIN T. V. SOCKET** for 31P1, 7J14, etc. Black bakelite 18c; Mica filled ..... 28c

**U.T.C. CHOKES P.A. CASES**  
10 HY. @ 66 MA. \$ .97 10 HY. @ 110 MA. \$1.40  
5 HY. @ 150 MA. 1.85 10 HY. @ 150 MA. 2.25

**T.G. 10 KEYSERS W/TUBES** ..... \$24.95

**FOLLOWING EQUIP. USED BUT LIKE NEW**

**U.H.F. SIGNAL GENERATOR** similar to R.C.A. Type 710A. 370 to 560 Meg. Ideal for citizens band ..... \$145.00

**TRANSTATS—3.9 KVA 1 Phase 50/60 cy. fixed winding 115/230 V. output 0-260 V., Max. amps. 15** ..... \$42.00

5.85 KVA 1 phase 50/60 cy. fixed winding 115/230 V. Output 0-260 V., Max. amps. 22.5 ..... \$52.00

**SINE & SQUARE OSC. Var. ± 20% @ 1100 CPS.** 20 Volts out, requires 6SN7 & 6SN7 Tube and 250 V. @ 10 Ma., 6 V. @ 1 amp. .... \$3.25

**LARGE QUANTITY OF SEMI-PRECISION FACTORY TEST EQUIP.** Pulse Gen., Pulse amp., Multi-Vib., Sig. Gen., Wavemeters, Delay lines, etc. Write Requirements.

### SOUNDTRONICS LABS.

632 Arch St., Phila. 6, Pa. MA 7-2775

### PATCH CORDS

6' rubber covered, two conductor, tinsel with W.E. Type 211A plug at each end. (Similar to Illustration) Weight: 4 lbs. Western Electric 211A plugs. Price \$2.00 each W.E. 217D plugs with 600 ohm load. .... \$2.65 each

**MASPETH TELEPHONE & RADIO CORPORATION**  
142 Ashland Place Brooklyn 1, N. Y.

### VACUUM PUMP SALE!

**CENCO MEGAVAC PUMPS**—\$79.00 each  
**CENCO HYPERVAC PUMPS**—\$159.00 each.  
Slightly used, guaranteed perfect operating condition. Write or Call:

**AMERICAN ELECTRICAL SALES CO.**  
67 E. 8th St. New York 3, N. Y.

### GEARED MOTOR



Ideal reversible motor for rotating antennas, displays, etc. (Similar to Illustration) Weight: 4 lbs. Overall size: 7" long, less shaft. Gear Box size: 3 1/4" x 3 3/4". Motor size 4" x 2 1/2". Shaft size: 3/8" x 1 1/2" threaded. Operates from 24 volt DC, 2.9 A., 9 RPM or 36 volt AC at 75 lbs. torque per inch. Price ..... \$5.95  
36 Volt Transformer ..... \$2.95

**RHEOSTAT** to control speed. 120 ohm. 50 Watts ..... .9c

### WHIP ANTENNA EQUIPMENT

**MAST BASES—INSULATED:**

MP-132—1" heavy coil spring, 2" insulator. Overall length: 11 1/2". Weight: 2 1/2 lbs. Price ..... \$3.95  
MP-22 Spring action direction of bracket. 4" x 6" mounting. Price ..... \$2.95  
MP-37—2" heavy coil spring, 5" insulator ..... \$3.95  
MP-48—2" heavy coil spring, 3" insulator ..... \$2.95  
MP-37—2" heavy coil spring, 8" insulator ..... \$3.95  
MP-47—2" heavy coil spring, 9" insulator ..... \$5.95

### MAST SECTIONS FOR ABOVE BASES:

Tubular steel, copper coated, painted, 3 foot sections. screw-in type. MS-53 can be used to make any length, with MS-51-50-49 for taper. Price, per section ..... 50c  
HAG BG-56 ..... 50c  
HAG BG-56 for carrying 5 mast sections ..... 50c Ea.

**SYNCHRONOUS MOTOR**—26 V. 60 cycle 60 RPM. Size: 1 1/2" x 2 1/4". Shaft 1" x 1/16". Type 1147, with 26-V. Transformer ..... \$2.95

**ALNICO MIDGET DC VOLTAGE GENERATOR**—Type PM-2 Electric Indicator Co. .0175 V. per RPM. 3 1/4" x 2 1/4". Shaft 1/2" x 5/32" ..... \$6.95

### DYNAMOTORS:

Input	Output	Stock No.	Price
12 V. DC	680 V. 210 MA.	DM-680	\$7.95
@ 6 V. DC	300 V. 150 MA.	DM-9450	
9 V. DC	450 V. 90 MA.	w/Blower	3.95
@ 6 V. DC	275 V. 50 MA.		
12/24 V. DC	440 V. 200 MA.	D-104	9.95
	220 V. 100 MA.	DM-175	2.95
18 V. DC	450 V. 60 MA.	DM-86	7.95
12 V. DC	600 V. 300 MA.		

**PERMANENT MAGNET FIELD DYNAMOTORS:**  
12/24 V. DC 275 V. 110 MA. USA/0516 3.95  
12/24 V. DC 500 V. 50 MA. USA/0515 2.95

**PM FIELD DYNAMOTOR POWER SUPPLY**—Completely filtered. Has two PM Dynamotors as listed directly above ..... \$5.00

**WRITE TODAY FOR QUOTATION ON OTHER DYNAMOTOR OR INVERTER NEEDS!**

### CONDENSER ASSEMBLIES:

**5 GANG**—with vernier tuning 25 MMFD to 450 MMFD each section. Size: 7 1/2" x 3 1/2" x 3 1/2". Price: \$2.95

**3 GANG**—25 MMFD to 450 MMFD each section. Size: 6" x 3 1/4" x 3". Price ..... \$1.95

**GENERATOR**—2 Volt 100 Amp. Mfg. by Emerson. 5400 RPM with 3/8" x 3/8" shaft and 4 mtg. holes on each end for right or left. Motor size: 8 3/4" x 4 3/4". Price: ..... \$12.95

**PI GENERATOR**—24 Volt 200 Amp. Price—NEW \$30.00



Address Dept. E. • • • All Prices Are F.O.B., Lima, O. • 25% Deposit on C.O.D. Orders

## FAIR RADIO SALES

132 SOUTH MAIN ST.

LIMA, OHIO

# BRAND NEW U. S. GOV'T. SURPLUS GUARANTEED

## POWER RHEOSTATS



Ohms watt ea.	Ohms watt ea.
2 225 \$4.95	150 150 \$3.50
3 100 2.90	100 25 .98
3 225 4.95	200 150 3.50
4 225 4.95	225 50 1.24
4 50 1.24	250 25 .98
4 100 2.90	350 25 .98
5 150 3.50	350 100 2.70
5 25 .98	375 150 3.50
6 50 1.24	400 25 .98
6 25 .98	500 25 .98
6 50 1.24	500 75 2.49
8 25 .98	585 150 3.50
10 100 2.90	750 25 .98
12 25 .98	750 150 3.50
15 25 .98	1000 25 .98
16 50 1.24	1200 225 4.95
22 50 1.24	1250 50 1.24
25 25 .98	1250 150 3.50
32 300 5.25	1500 50 1.24
50 25 .98	2000 25 .98
50 50 1.24	2000 50 1.24
50 750 17.95	2500 100 2.90
60 25 .98	3000 25 .98
65 150 3.50	3000 100 2.90
80 50 1.24	3500 50 1.24
80 500 7.60	5000 25 .98
100 25 .98	5000 50 1.49
100 50 1.24	7500 50 1.63
100 225 2.70	7500 100 3.30
125 25 .98	10000 50 1.63
125 500 7.60	10000 100 3.50
150 50 1.24	20000 150 5.26

Specify whether shaft required is for knob or screwdriver adjusted. (Discount to Quantity Users.)

## OIL CONDENSERS

Mfd.	Volt.	Each
.1	3000	\$0.75
.25	2000	.95
.25	3000	1.10
.25	3500	1.35
1	500	.28
1	600	.35
1	2000	1.95
2	400	.30
2	600	.39
4	600	.69
6	400	.75
6	600	.79
6	600	.98
14	600	1.75
15	600	1.98
15	1000	3.25
2x 1	7000	3.95
3x4	400	1.49

Plug-in

## TYPE "J" POTENTIOMETERS



Specify whether regular or screw-driver shaft is required.

### TYPE "J" 50c

ohms	ohms	ohms
60	2000	20K
100	2100	25K
150	2200	30K
300	4000	50K
400	4700	75K
500	5000	80K
600	10K	100K
1000	11K	200K
1200	12K	250K
1400	15K	300K
1500	16K	1meg

### TYPE "JJ" \$1.25

ohms	ohms
100-100	100K-100K
200-200	130K-130K
500-500	150K-150K
600-600	200K-200K
1500-1500	250K-250K
2000-2000	300K-300K
5000-5000	350K-500K
10K-10K	350K-25K
20K-200K	500K-500K
25K-10K	800K-75K
35K-5000	1meg-1meg
50K-50K	5meg-5meg

### TYPE "JJJ" \$2.25

ohms
20K-200K-20K
45K-27K-250K
700K-700K-700K
750K-750K-750K
800K-800K-800K
1meg-1meg-1meg

When ordering locking type bushings, locking nuts are available in the following types:  
Hex shaft lock @ .05  
Acorn " " @ .10  
Knurled " " @ .10

## BATHTUBS

mfd	vdew	each
.033	400	.17
.05	200	.17
.05	400	.19
.05	600	.21
.1	400	.22
.1	600	.22
.1	1000	.32
.15	600	.22
.25	200	.19
.25	600	.23
.35	400	.22
.5	400	.23
.5	600	.25
.5	1000	.35
1	200	.29
1	600	.35
1	1000	.44
2	600	.59
4	50	.25
8	500	.59
25	50	.28
25	75	.30
40	25	.27
50	25	.28
200	12	.35
300	6	.39
.05-.05	600	.29
.05-.05	1500	.45
1-.05	200	.25
1-.1	400	.26
1-.1	600	.28
16-.16	600	.28
2-.2	600	.29
25-.25	600	.30
5-.5	600	.35
10-.1	300	.29
200-200	9	.49
3x .05	600	.40
3x 1	400	.42
3x 1	600	.45
3x .25	600	.50
3x 1.0	100	.40

## TRANSMITTING MICAS



mfd	vdew	type	ea.	mfd	vdew	type	ea.
.00001	600	4	.18	.00162	600	4	.18
.00003	600	4	.18	.002	600	4	.20
.00005	600	4	.18	.002	1200	4	.48
.00005	2500	9	.31	.0022	2500	9	.78
.0001	600	4	.18	.0025	600	4	.23
.0001	2500	9	.31	.003	600	4	.25
.000152	600	4	.18	.0039	600	4	.25
.0002	600	4	.18	.005	600	4	.25
.00025	600	4	.18	.005	1200	9	.60
.0005	600	4	.18	.005	2500	9	1.18
.00051	2500	4	.43	.0062	600	4	.30
.0007	600	4	.18	.01	600	4	.40
.0008	600	4	.18	.01	600	9	.49
.0009	600	4	.18	.01	1200	9	.98
.001	600	4	.18	.0142	600	4	.45
.001	1200	4	.31	.02	600	4	.55
.001	1200	9	.31	.02	1250	9	1.36
.0013	600	4	.18	.027	600	4	.66
.0015	600	4	.18	.043	600	4	.99

## "UH" Coax Cable CONNECTORS



Cat. No.	Army No.	Type	Ea.	Per/C
83-IAP	M-359	Plug	.35	.28
83-ID	PL-271	Adap	1.25	1.00
83-IF	PL-274	Feed	1.10	.90
83-IR	SO-230	Rec	.35	.28
83-ISP	PL-259A	Plug	.35	.28
83-22R	SO-264	Rec	.50	.40
83-22SP	UG-102 U	Plug	.45	.40

Open Accounts to Rated Concerns  
Prices net FOB our warehouse NYC.  
Send for our Catalog

# OFFERED FOR SALE

One FTR Type 192A, 3 Kilowatt FM Radio broadcast transmitter covering frequency range from 88 to 108 megacycles complete with 2 sets of vacuum tubes. For operation from 220 volt 60 cycles 3 phase AC power source. Unused, in perfect condition. Value approximately \$12,000.

Two Type 571-3-CWF 4.5 Kilowatt AM High Frequency radio telephone and telegraph transmitters for operation on any one of 3 preset frequencies in the 5 to 16 megacycle band, each complete with 4 sets of vacuum tubes, microphone, telegraph key, spare parts and interconnecting cables. For operation from a 220 volt, 50/60 cycle 3 phase power source. Unused, in perfect condition. Value approximately \$22,500.

For further technical details write or call Mr. W. A. Eubanks, EOWling Green 9-3800, Extension 248. Address bids to attention of Assistant Comptroller.

## International Standard Electric Corporation

67 Broad Street  
New York 4, N. Y.

## THE DOMINIK SURPLUS CO.

187-28 87th Rd. JAMAICA, L. I.  
Motors, Pumps, Wire, Etc.  
WRITE FOR LIST

## WILL BUY ALL BC-348'S WITH DYNAMOTORS

Letters "J", "N" & "Q" .....\$60.00 ea.  
All others except "C" .....\$50.00 ea.  
Ship via Express C.O.D. subject to inspection to:  
H. FINNEGAN  
49 Washington Ave. Little Ferry, N. J.

## WANTED BC 348Q } RADIO BC 639 } RECEIVERS - Original condition

TITFLEX, INC.  
500 FRELINGHUYSEN AVENUE  
NEWARK 5, NEW JERSEY

## WANTED TEST EQUIPMENT

state asking price, age and condition in first letter.  
W-1150, Electronics  
330 W. 42nd St., New York 18, N. Y.

## WILL BUY

Any quantities of new or used Electronic Surplus Equipment:

APN-9, RTA-1B, TS-67, TS-170  
ARC-1, ARC-3, ART-13, BC-221,  
BC-348, SCR-522, etc.

State Condition and Best Price

W-1476, Electronics  
330 W. 42nd St., New York 18, N. Y.

## WANTED TO BUY

Large and small quantities of new or used electronic government or manufacturers' surplus tubes and equipment. Highest prices paid. State quantity, condition and best price in first letter.

W-2369, Electronics  
330 W. 42nd St., New York 18, N. Y.

## WANTED WESTERN ELECTRIC VACUUM TUBES

Types 101F, 102F, 272A, 274A or B, 310A or B, 311A, 313C, 323A, 328A, 329A, 348A, 349A, 352A, 373A, 374A, 393A, 394A, 121A Ballast Lamps.

W-6641, Electronics  
330 West 42nd St., New York 18, N. Y.

## WANTED

Teletypewriters complete, components or parts. Any quantity and condition.

W-6654, Electronics  
330 West 42nd Street, New York 18, N. Y.



**A. C. POWER ANYWHERE**

with Katolight Plants  
and Generators

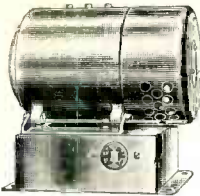

**CONVERTERS**

One 350 Watt, 115 Volt D.C. input, 115 Volt A.C. output... \$52.00  
Three 2.5 KW, 230 Volt D.C. input, 115 Volt A.C. output, 60 cycle, \$160.00 each

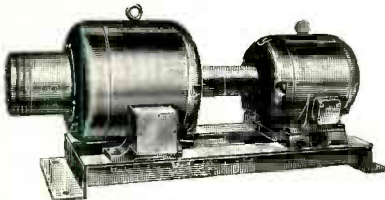

**MOTOR GENERATOR SETS**

One 2000 Watt, 120 Volt D.C. output, driven by a single phase, A.C. 115/230 Volt Motor... \$240.00  
One 1000 Watt, 110 Volt A.C. Generator, driven by a 110 Volt, D.C. Motor... \$220.00

**LIGHTING PLANTS**

Three 2500 Watt, 115 Volt, 60 cycle, A.C. \$250.00 each.

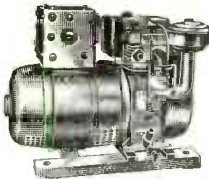

All offered subject to prior sale

Manufacturers of electrical machinery since 1928

**KATO ENGINEERING COMPANY**  
105 Maxfield Avenue  
Mankato, Minnesota

**"TAB" THAT'S A BUY**



**RECTIFIERS BRAND NEW!**

Sensational BRADLEY Double Bridge Balanced Current & Temp 1% from -40° to +68°C. Inpt to 4.5VAC, Output to 3VDC/5Ma. Only 98¢

36Vin/30Vout/150Ma Selen w/mtg flange, 2 units can connect in C.T. for Full Wave; 4 units usable as Full Wave Bridge. Unit 36¢; 2 for 60¢; 4 for \$1.00	100Ma Selen, 69¢; 200 Ma Selen 98¢
<b>Input Output Amps Each</b>	
<b>Full-Wave Center Tapped</b>	
18V 14V 1.35 \$2.49	
36V 28V 3.5 1.49	
<b>Full-Wave Bridge Rectifiers</b>	
18V 14V 3.5 3.98	
18V 14V 6.4 5.25	
18V 14V 8 6.98	
18V 14V 13 8.95	
18V 14V 17.5 11.55	
36V 28V 3.5 8.49	
36V 28V 5 8.49	
90V 75V 0.15 1.49	
135V 115V 3.5 18.49	

**Mercury Thermo-Regulator**

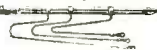

Instant Action, Dual Ckt 105°F & 32°F. Hi-Sens & Accy.—for Most Exacting Requirements—RESEARCH, PIRE, PREVE, FREEZE PT CONTROL, or MAX-MIN Temp Control. Brand New. Individual Boxed w/data & ckt; List over \$20. SPECIAL .98¢; 12 for \$10



**Microwave Lightghouse**

Assy D/ORT39/APG5&15. Osc & TR cavities. Type N coupling. Uses 2C43, 2C40, 1B37. Tunes 21-2700Mc. N1P1. NEW \$29.95



Hi Pwr Var Ant Netwk 1001A 1KW HiF RF 1.5 to 7 Mc's NEW Convertible III Freq. 1 $\frac{1}{2}$  Net Adj IN & OUT. Cds 15 X 15 X 23" Rack Mfg. Ribbon Coil 240 mm/7000V Cndsr. RF meter, Instrs, Manual. Matches Most Ant's. 4" etched dials. BRAND NEW (Coil and Standoff dngd). Worth 10 times price for Parts Alone. \$7.98



**CIRCULAR SLIDE RULE** Equip 12"—Only 2- $\frac{1}{2}$ " Radius. LAMINATED—Print Stays On! Multi Div. Sqs. Cubes & Roots, Logs & Dec Scales. Data & Case... 98¢



**G-E 2161 Selsyns** 400 cycles; Usable 24V or 110 VAC Tested, Used, Guaranteed W/data... 2 for \$1.49

**G-E Liquid Level Transmitter** Amazing \$100 "TAB" Special! General Electric Selsyn for Remote Indication of liquid present in tank. Approx. Govt Cost \$100. NEW! 2 for 89¢

**PRECISION RESISTORS — Over 2,500,000 in Stock,**

"TAB"—Specialists in Precision Resistors

0.116	74	340	697	1818	2463	6000	14400	33000
0.125	75	350	699	1830	2485	6100	14500	35000
0.132	80	360	700	1865	2490	6125	14550	37000
0.607	81.4	366.6	711	1892	2500	6140	14600	38140
0.7	88	370	733	1894	2525	6200	15000	38500
1.08	89.8	375	740	1895	2600	6300	16000	39000
1.3	90	380	750	1896	2625	6495	16500	39500
1.75	95	389	800	1897	2635	6500	16800	40000
2.5	100	390	806	1898	2700	6840	17000	42000
3	101	400	850	1899	2750	6990	17500	43000
3.83	105	410	854	1900	2850	7000	17977	45000
1	105.7	414.3	899	1901	2860	7320	18000	47000
4.35	107	418.8	900	1902	2870	7500	18300	47500
5	120	425	910	1903	2900	7700	18380	48000
5.025	121.2	426.9	917	1904	3000	7717	18500	48600
6.25	125	427	946	1917	3100	7900	18800	49000
6.5	135	440	978	1906	3163	7930	19000	50000
7	140	450	1000	1907	3259	7950	19500	52000
7.8	147.5	452	1030	1908	3290	8000	20000	55000
7.9	150	460	1056	1909	3333	8094	20441	56000
8	160	470	1067	1910	3384	8250	20500	57065
10.38	165	475	1100	1911	3416	8300	21000	58335
11.25	170	478	1110	1912	3509	8700	21500	60000
12	175	480	1150	1913	3700	8770	22000	61430
13.52	179	487	1155	1914	3730	9000	22500	62000
14.2	182	500	1162	1915	3760	9100	22990	64000
14.25	182.4	518	1175	1916	4000	9445	23000	65000
14.5	200	520	1917	4030	9400	23150	66600	
15	209.4	525	1225	1918	4200	9710	23325	66650
16	216	540	1250	1919	4220	9800	23400	67500
17	220	550	1260	1922	4280	9900	23500	68000
19	220.4	575	1300	1924	4300	9902	24000	70000
19.2	225	580	1322	1928	4314	10000	24600	72000
20	230	588	1300	1960	4440	10500	25200	75000
22	235	600	1355	1980	4444	10500	25200	80000
23	240	612	1400	2000	4500	10600	25400	82000
24	245	625	1488	2045	4720	10900	25833	82000
25	245.4	633	1495	2080	4750	10936	26000	84000
26	250	640	1500	2095	4850	11000	26500	85000
28	260	641	1510	2141	4900	11100	27000	88000
30	271	645	1518	2142	4900	11150	27000	88000
31.5	275	649	1600	2145	5000	11690	27500	90000
37	280	650	1640	2150	5100	12000	28000	91000
48	286	657	1646	2160	5210	12500	28430	93300
49	289	665	1650	2180	5235	12600	28500	95000
50	290	670	1670	2187	5270	13000	29000	
51.78	300	673	1650	2195	5300	13000	29500	
55	310	675	1710	2200	5500	13500	29990	
56.7	311.5	680	1712	2250	5600	13550	30000	
60	320	681	1740	2300	5730	13600	31000	
63	325	684	1770	2400	5770	14000	31500	
68	330	689	1800	2450	5910	14250	32000	

100000	150000	190000	238000	314000	420000	570000	800000
110000	155000	198000	240000	316000	422000	575000	810000
115000	160000	200000	245000	325000	425000	600000	850000
116667	165000	201000	250000	330000	430000	620000	900000
120000	167500	205000	265000	333000	459000	650000	930000
125000	170000	210000	268000	333500	478000	654000	950000
130000	169200	215000	270000	350000	500000	660000	
135000	175000	220000	275000	353500	520000	690000	
140000	180000	225000	294000	375000	521000	700000	
141000	180600	229000	300000	380000	525000	716300	
145000	185000	230000	307500	400000	543000	750000	
147000	186600	235000	311000	402000	550000	761300	

Any Size Above, Each	35¢	Ten for	\$2.98
Megohms	1.65 2.25 3.3 4.25 6.5 8.02 12.83		
1	1.39 1.75 2.5 3.5 4.5 6 7.5 9.05 13.85		
1.1	1.4 1.8 2.7 3.673 4.7 6.7 8.5 13		
1.2	1.5 1.9 2.75 3.75 5 7 9.05 13.85		
1.25	1.57 2 2.8 3.9 5.5 7.5 9.5		
1.3	1.579 2.11 2.855 4 6 7.62 10		
1.35	2 2.2 3 4 6 7.74 11.55		

Any Size Above, Each	70¢	Ten for	\$5.98
Hi Volt Hi Freq Resistors	1Kv/1/2" \$1.95		
MVT 2 1/2 Meg/5W/7.5KV	\$1.08		
MVP 5 or 10 Meg/10W/10KV	\$1.49		
12 Meg/10W/10KV	\$1.49		
MVZ 30 Meg/20W/25KV	\$1.98		
MVE 50 Meg/20W/40KV	\$1.98		
HiV HiFreq Precision Resistor			
MFC 105 Jan-R29 1 Meg/			

**"TAB" THAT'S A BUY**

DEPT. 4E, SIX CHURCH ST. NEW YORK 6, N.Y., U.S.A. - CORNER CHURCH & LIBERTY STS. ROOM 200

**FEDERATED "MOVING DAY" SPECIALS**

**HIGH VOLTAGE, HEAVY DUTY OIL CAPACITORS**

in steel rectangular cases with husky porcelain insulators. Made by a leading condenser manufacturer. This is NOT war surplus! Brand new. Our sale price is a fraction of the regular price.

2MFD. 7500 Volts DC Manufacturer's list price \$151.00. Your cost at Federated.....	\$22.50
1MFD. Condenser 10 Volts DC Manufacturer's list price \$197.00. Your cost at Federated.....	\$27.50
2MFD. 12,500 Volts DC Manufacturer's list price \$265.00. Your cost at Federated.....	\$36.00

**SPECIAL PURPOSE TUBES**

Brand new—in original manufacturer's carton WL 655/658 (Westinghouse) Regular price \$241.00.	NOW \$75.00
WL 652/657 (Westinghouse) Regular price \$73.50.	NOW \$21.50
827R (RCA) Regular price \$173.00	NOW \$39.00

<b>SPECIAL PURPOSE TUBES (surplus)</b>	
RX233A .....	only 90¢
RKR73 .....	only 39¢

**SENSATIONAL PRICE REDUCTION on RCA TEST OSCILLATOR WR67A**

Frequency range continuous. 100KC to 31 MC. In six bands. Calibration accuracy plus or minus 2%. Output voltage continuously variable five microvolts to 1 V. RMS. Internal modulation 400 CPS adjustable from 0% to 50%. Regular price \$89.50. NOW \$49.50

\* We are now located at new enlarged quarters at 66 Dey St., New York City. These improved facilities make it possible for us to offer you better service and greater values than ever before.

**Federated Purchaser**  
INCORPORATED  
NEW YORK CITY ALLENTOWN, PA.  
66 DEY STREET 1115 HAMILTON ST.  
Dlgbly 9-3050. Allentown 3-7441

**CLARE STEPPING SWITCHES**

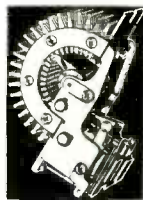

Type SD-14, 20 steps, 6 levels. Coil 12V, DC. Lists at \$40.26; our low price \$13.00. Brand new in original boxes—not war surplus. Quantities of four or more, \$12.25 each. Satisfaction guaranteed or money refunded.

**NEOMATIC, INC.**

879 Wellesley Ave., Los Angeles 49, Cal. Arizona 3-4897

**FOR SALE**

**20-30 MC BROAD BAND CONVERTERS**

a five position pretuned unit employing 3 tubes with an output frequency of 5mc is offered at the low price of \$16.00 postpaid. Completely guaranteed. Suitable for BC348, BC342 etc.

Weston Laboratories, Weston 93, Mass.

**RADAR EQUIPMENT**

SCR-717B APS-3 APS-4 SO-9 Search Radars Complete  
APR-1 and APR-4 Receivers with Tuning Units  
DP-12 Direction Finder  
TS-51/APG-4 Test Set

**W. E. COMPUTER POTENTIOMETERS**

D-170541 D-170542 D-170543 D-170545 D-170546  
D-170548 @ \$10.00  
2136 Magnetrons @ \$75.00

Are Connectors @ .25  
6963—18 Contact Female  
55916—18 Contact Male Chassis  
9488—3 Contact Female  
55915—3 Contact Male Chassis

Write for Listings of other surplus bargains

**LERU LABORATORIES, INC.**

360 Bleecker St. New York 14  
OR 5-3525





# ACORN

Serves Schools, Labs, Industrials—  
Same Day Service



### BIRCHER CLAMPS

926 A1 926 B10 926 C5  
926 A16 926 C 926 C8  
926 B2 926 C2 929 1  
926 B5 926 C3  
**\$11.50**  
13c ea. per 100

### WIRE WOUND RESISTORS

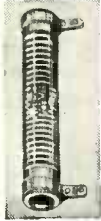

Watts	Each	Per C
5	.12	\$10
10	.18	20
20	.25	25
25	.30	24
50	.55	50
75	.65	60
100	.75	70
200	.85	75

We have on hand a tremendous stock of popular sizes in the above resistors.



### Ceramicon Trimmer

Erie Type 554  
3-12 MMF  
5-25 MMF  
8-50 MMF  
**.15**  
each  
**\$10.00**  
per 100



### APC AIR TRIMMERS

	Each	Per 100
15 MMFD. with shafts	.25	\$20.00
15 MMFD. screwdriver	.20	15.00
25 MMFD. with shafts	.30	25.00
25 MMFD. screwdriver	.25	15.00
50 MMFD. with shafts	.45	35.00
50 MMFD. screwdriver	.25	20.00
60 MMFD. with shafts	.30	25.00
60 MMFD. screwdriver	.50	45.00
75 MMFD. with shafts	.50	40.00
75 MMFD. screwdriver	.40	30.00
100 MMFD. with shafts	.60	45.00
100 MMFD. screwdriver	.40	30.00
140 MMFD. with shafts	.75	60.00
140 MMFD. screwdriver	.50	45.00



### WESTON METER 506

0 to 500 microamp basic.  
Scale 0 to 15 V. and 0 to 600 V, 2 1/2". **\$3.49**

### MICA TYPE F CONDENSERS—CM 65 & CM 70—Very Special Low Price

Quantities of 25 or more, deduct 10%			Quantities of 100 or more, deduct 20%		
Cap.	Volt.	Each	Cap.	Volt.	Each
1	1000	\$1.26	00025	3000	\$ .73
05	1500	1.32	0004	3000	.73
075	1500	1.36	00075	3000	.77
00008	2000	.50	001	3000	.79
01	2000	1.08	0035	3000	1.08
00003	3000	.58	0001	5000	.77
000075	3000	.58	0002	5000	.77
0001	3000	.58	00025	5000	.77
0002	3000	.73	00032	5000	.77
			0004	5000	.77
			0005	5000	.84
			0006	5000	.84
			0008	5000	.94
			001	5000	.94
			0012	5000	.94
			0015	5000	.94
			00004	6000	1.11

PHONE WORTH 4-3270

**ACORN ELECTRONICS CORP.**  
76 Vesey St., Dept. E-4, New York 7, N. Y.

TERMS: 20% cash with order. Balance C.O.D. unless rated. All prices F.O.B. our warehouse in New York City. No orders under \$2.50.

## BARGAINS!

## BARGAINS!

## BARGAINS!

### NEW RA-38 RECTIFIERS

115 v., 60 cy. 1 phase input, output 0-15,000 v. d-c @ 500 ma. Write for detailed information.



### ASD RADAR TRANSMITTER & MODULATOR

3 centimeter: complete with 725A magnetron, cavity, two 723A/B Klystrons, one RK173, four 72's, one 1153, one 820B, two 724B's, two 6AC7's, one 1N23 crystal diode, high voltage supply, two cooling blowers, etc. Input: 115 v. 400 c. N-2 condition ..... \$39.50  
Preamp assembly: includes plumbing (2) 723 A/B's, (2) 6AC7's, (2) 724B's, 1N23, etc ..... \$17.50

Immersion heater, Westinghouse, low surface, 3 heat, oil type, 115 v. 200, 400, and 800 watt. 1 1/2" male pipe connection with calrod elements projecting 3/4". List \$17.20. Our price \$6.50 each, 2 for \$10.00.

TRANSTAT, 115/220 v. 50/60 c., 0-260 v. 2 1/2 amp. cont., 5 amp. max. output. New. Original packing. List \$43.00. \$17.50 each, 2 for \$30.00.

### TUBES:

Discount 20% on orders over \$50.00

1B22	\$4.25
1N23	.50
2362	37.50
3B22	2.50
4B22	2.75
15E	1.25
127A	2.25
250TTL	19.50
304TL	.95
316A	.35
388A	2.75
700A	9.75
701A	3.50
702A	2.75
703A	2.75
704A	1.00
706BY	12.50
706EY	12.50
707A	12.50
707B	7.00
708A	2.75
713A	7.75
714AY	3.75
715A	7.50
715B	6.50
719A	9.50
721A	2.75
722A	7.50
723A/B	8.50
724B	2.50
725A	8.50
730A	10.50
750TL	45.00
829B	3.50
846	47.50
872A	1.75
C5B	7.75
C6A	8.25
6B1	4.75
FG81A	3.75
WE-203A	8.75
VT98 (Br)	12.50



### Filament Transformer

371, 5563 etc., rectifiers. Net Wt. 16 lbs. \$12.50 each, 2 for \$22.50, 4 for \$40.00.

METER, 3" Roller-Smith, 1 ma. f.s.s., calibrated 0-4 KV d-c; and 4 Weston precision 1 meg. meter multipliers. \$3.75 each, 3 for \$10.00.

CAPACITOR, 4 mfd. 1000 wv d-c, new, original boxes. \$.60 each, 4 for \$2.00.

SELENIUM RECTIFIER, 6.5 v. a-c., FWCT, 2.2 v. d-c @ 3 amps., new, original boxes. \$.75 each, 4 for \$2.00.

More Values In Our Surplus Bulletin—Send For Yours Today.

## EPCO

1527 E. SEVENTH ST.  
Los Angeles 21, Calif.

### Reduce Your Shipping Costs

Closeouts on surplus stock—don't buy your Corrugated Cartons or Folding Boxes until you see us.

**BERRY BOX CO., INC.**  
1013 Broadway Brooklyn, N. Y.  
Tel. GLEmore 5-0402, 8906  
We also buy surplus cartons

### R.C.A. Electronic Counters

#### FOR SALE

Two type WF98A and WF99A

Complete with all accessories

Springfield Machinery Exchange  
20 Belle St. Springfield, Mass.

## TUBES

1N21	\$0.95	803	\$4.95	892R	\$250.00
1N23	1.25	804	12.95	5R4GY	1.25
1N34	.85	805	5.95	5U4G	.79
1N35	2.05	810	8.95	5X4	.79
283A	10.95	811	2.49	6Y3GT	.55
303A	3.95	813	8.95	5Z3	.69
307A	3.75	814	3.95	6C4	.25
2J21A	12.95	816	.95	80	.49
2J36	99.50	820B	7.95	83	.79
2K25	24.50	830B	5.25	2050	1.10
2K45	99.50	832A	4.95	2051	.95
GL502	1.95	836A	.75	0A2	1.55
715B	9.95	837	2.50	0B2	1.75
715C	24.95	845W	4.85	VR75	.89
723AB	9.95	866A	1.15	VR105	.89
725A	9.95	872A	2.10	VR150	.69

### 3" METERS

0-50 ua DC WH	\$17.50	0-15 VAC WH	\$3.95
0-50 ua DC RS	13.50	-10+6 DB West 301	8.95
0-200 ua DC WH	10.50	0-150 VAC TRIP	5.95
0-500 ua DC 4" SQ	5.95	0-150 VAC WH	6.95
0-1 MA DC WH	7.50	0-30 AMP ACTRIP	5.95
0-1 MA DC S scale	3.95	0-75 AMP ACTRIP	5.95
1-0-1 MA Sp Sele.	2.95	FRAN Freq. Mtr.	7.50
0-2 MA DC WH	5.95	60 cy	7.50

### 2" METERS

0-20 MA DC WH	3.95	0-1 MA GE	3.95
0-50 MA DC WH	4.75	0-1 MA WEST 506	4.50
0-100 MA DC DEJ	3.95	0-3 VDC GRUEN	3.50
0-200 MA DC GE	3.95	0-30 VDC GE	3.50
0-1000 MA DC DEJ	4.95	0-1 AMP RF GE	3.50
0-2 AMP DC SIMP	5.95	0-8 AMP RF WH	3.50
0-300 VDC WEH	7.95	0-30 AMP DC GE	3.50
0-500 VDC WH	7.95	0-10 VAC GE	3.50
0-8 VAC WEST 476	3.95	0-300 VAC TRIP	5.95

### CHOKES

8 HY 50 MA 90 ohm	\$0.39	6 HY 250 MA 90 ohm	2.95
10 HY 80 MA 240 ohm	.75	5 HY 300 MA 75 ohm	3.50
10 HY 150 MA 140 ohm	1.10	200 HY 6 MA 620 ohm	.99

### OIL CAPACITORS

2 MF 600 V	.69	2 MF 1500V	1.75
4 MF 600V	.79	2 MF 2000V	2.49
6 MF 600V	.89	4 MF 2000V	3.95
10 MF 600 V	1.10	25 MF 3000V	1.95
10 MF 1000V	2.49	1 MF 15,000V	19.50

NEW WESTON Model 1 Lab Standard 1/2 of 1%, 0-150, 0-1500 MA D.C. Calib. Chart & Case \$49.50  
WESTINGHOUSE PY-4 0-25 MA AC Lab Meter \$18.95

PRECISION 100 KC XTAL \$5.95  
CRAMER TIME DELAY RELAY 120 V, 120 SEC. \$7.95

FIL. TRANS. 6.3 V @ 10A, 110 V 60 CY. \$1.75  
10K or 50K 100 W. RESISTOR .49  
CHOKO, ICA205, 60 MH \$1.50  
.002 Mf 500 V SILVER MICA \$1.10 for \$1.50  
25% Deposit with order, balance C.O.D.

Send for "POLY-GRAM"

## POLY-TECH N. Y.

919 Dawson Street, New York 59, New York

## NEW BENDIX PLATE TRANSFORMERS

A limited supply of original packed high quality plate transformers are offered for sale. Operating from 200/220/240—1ϕ 50-60 cycle lines, these fine units deliver 2900VCT • 4KVA. Insulation tested at 9000v and weighing 220 lbs. each, they represent a \$500.00 list value. Specially priced at \$94.00 each FOB.

**WESTON LABORATORIES**  
WESTON 93, MASS.

## OSCILLOSCOPE

DUMONT MODEL 208 B

Almost New

PRICE \$160.00 with P7 TUBE

**KREMENTZ & COMPANY**

49 Chestnut Street Newark, N. J.

### FOR SALE

Two complete reactor

## TRANSFORMER KITS

for use with PW40A transmitter. Over forty pieces per kit including the 67KV plate transformer. For details address

FS-2371, Electronics  
330 W. 42nd St., New York 18, N. Y.

### FOR SALE

One General Radio 707 A Cathode Ray

## NULL DETECTOR

Good Condition with phasing and tuning unit

T. K. JEFFERIS

801 Lake Shore Detroit 30, Mich.



# ELECTRO—THE BEST FOR ELECTRONIC SURPLUS

## NEW SWITCH INTERLOCKS



Cory Type B857, Single Key Oper. Interlocking of doors, vaults, reactor or resistor enclosures, oil circuit breakers, etc. \$1.98  
Cory Type B886, Single Key Oper. SPST SW w/Yale Cyl Lock 60A tumbler lock \$2.49  
Cory Type B1536, Supervisory Oper. 2 key type \$2.95

GE GLYPTOL #1253. Dark gloss green 1 gallon, fresh stock \$3.95

GE GLYPTOL #1209. Semi-gloss black 1 gallon, fresh stock \$3.95

## AMERTRAN HEAVY DUTY TRANSFORMERS



Pri 115/230 VAC 60 cy. Sec. 4730/2365. KVA 1.66 RMS 12 KV Wgt. 150# 11" x 11" x 9" Brand New \$37.50

NAVY TYPE CDQ 21767 AC MOTOR, Mfr. Dormeyer Co., W.E. #KS-5913L01. 115V 0.32A, 1 ph, 60 cy, 1/50 HP, 1725 RPM. Shaft 1 1/2" L x 1/4" D. Complete w/3.75 mfd capacitor. New \$7.95

## SELSYNS

115 V., 60 Cyc. 3 1/2" dia. x 4 1/2" body #C78248 \$7.25 pair

A-62 PHANTOM ANTENNA, inductance 1.35 uh; 60 ohm; 50W resistor in series w/100 mmf variable capacitor mtd in metal box 2 1/2" x 7 1/2" x 2 1/2". New \$1.95

## VIBRATOR POWER SUPPLY (PE 204A)



Used with Telephone Repeater EE-99A. Input 12 VDC. Output 2 windings @ 4.3 VDC @ 50 MA; 2 @ 45 VDC @ .5 MA; 2 @ 85 VDC @ 5 MA. Loaded with parts. New \$1.95

MOUNTING FT-178, used w/Command Sets. Uses Lord #150PH6 shock absorber & reinforcing steel plate. New \$1.00

TIME DELAY RELAY, Mfr. R. W. Cramer Co. motor operated, 110V 60 cy., 5-minute. New \$3.95

## TRANSTAT VOLTAGE REGULATOR



Amertran type RHL. Input: 115 V. 400 cy. 0.5 KVA, 5.5 max. amps. Output: 92-115V. 5/8" x 4 1/2" x 3 1/2" \$1.95

.25 KVA Fixed winding 115/1/60. Commutator range 103-126 V. 2.17 Max Amps \$9.45

## SINE-COSINE GENERATORS

(Resolvers) FPE 43-1, Diehl, 115 V., 400 cycle. \$29.50

## RATE GENERATORS

F16, Electric Indicator Co., two-phase, 22 V. per phase at 1800 r.p.m. New \$7.95

ELECTRIC HEATERS, Navy type C, 115V, 2000W, 17.4A. Two heating elements. Like New \$4.95

## SPERRY A-5 VERTICAL GYRO UNIT



#844841. 115 V. 400 CY 3 phase. Contains gyro assembly, erection motor, erection relay assembly, pick-off assembly, elevator and aileron limit switches, and roll axes. 15 x 12 x 9 New \$27.50

AH&H NAVY ROTARY SWITCH, 60A @ 500 VAC, 60A @ 250 VDC. TPST, off-on-off-on. New \$3.95

## SELECTOR SWITCHES



Heavy duty, U. S. N. Control any type of multi-circuit devices. Removable contacts enabling any comb. of closed and open circuit. The following available: 5 section-10 pole or 10 section-20 pole. \$1.50 ea. Case lots of (8) \$8.00 or (5) cases, special \$32.50

## STANDARD BRAND CAPACITORS

Inerteen type FL 7500 VDC. .135 MFD. 13.5 Meg. resistance. Style 1227191-A. Precipitron Service. New \$6.95

Synchro Capacitor Cat. #25F613. Rated at 90 volts 3 ph. 60 cy., 30 Mu-f. New \$4.95

Cat. #14F201. Rated at 16-8 KV., .375-.75 Mu-f. New \$9.95

Bathtub #42308. Rated 5-3-1-1 Mu-f., 150 VDC. New \$1.00

Fast High Voltage type AE6734. Rated 1.0 Mu-f. 25 KV. Oil-filled. New \$60.00

Cat. #25F774. Rated 0.1-0.1 Mu-f. 7000 VDC. \$2.95

Motor Starting Capacitor #S25784-1. Rated 2 x 160 Mu-f. 150 VDC. New \$2.90

Fast High Voltage Oil Filled #A7548. Rated at 0.25-0.25 Mu-f. 6-12 KV. New \$14.95

Mica type PL1159-30H. Cap. 0.115 mfd. 2000V. 15A @ 3000 KC, 20A @ 1000 KC, 20A @ 300 KC. New \$3.95

## DECK ENTRANCE INSULATORS

(Bowl and Flange Type)



Ceramic, lead in; brown porc. bowl 6 1/2" base dia 7" high above mtg surface, overall 8-5/32" ht; equipped w/3/8" dia brass rod 10-15/16" lg threaded on both ends; and GI mtg flange 10 1/4" dia w/4 machine bolts 1/2"-2" lg 9" on mtg/c. SC #3G1350-21 \$3.50

MOUNTING FT-253, steel base plate fitted w/shock mts supports radio rec, radio xtmr & associated dyn; 3 3/4" x 12 1/2" x 2". Used w/SCR-506. New \$5.95

POWER UNIT ASSEMBLY, BENDIX 4504. p/o SCR572A. S.C. #3HX4595-1 \$4.95

WESTON TACHOMETER MAGNETO, Model 44, type A, max RPM 2000. Open circuit voltage 6V @ 1000 RPM, 20 ohm res. \$21.00

## TRANSTATS



11.5 KVA 50/60 cy. Commutator range 0-115 V. Max. Amps 100. Reconnection diagram available for 230 V 50A oper. Brand New \$100.00

## DUST COLLECTORS

These machines, manufactured by the Torit Mfg. Co. of St. Paul, Minn., are used for extraction of any dust from the air. They consist of a suction blower driven by a GE 1 1/2 HP Motor; Type K; 220/440-3-60, 3475 RPM, and the entire unit is housed in a heavy steel case with louvers for dust intake. \$100.00

## MINE DETECTOR SCR 625



Detects metallic objects (ferrous or non-ferrous) to a depth of approx 6 ft. Find out-board motors on the bottom of lakes, locate underground piping, treasure, metallic fragments in lumber, etc. New, complete with inst. book \$65.00. Used but like new \$45.00



## MILLIAMMETERS

150-0-150 MA DC. Accuracy 1/2 of 1%. Scale length 4 1/2". Wt. 3 1/2 lbs. 6" x 2 1/2" x 4 1/2". Like New \$2.50

ANTENNA CHANGE-OVER SWITCH, mfd. Square D., SPDT, New \$5



## DAVEN SOUND ATTENUATORS

Type 350-A. Network, ladder, linear, impd. 30/30 ohms. 2DB attenuation. 10 W dissipation. Brand new \$3.95

SIGNAL CORPS TUNING UNIT BC-233, Mfr. Bendix Radio, Wt. 150# \$19.95

## 27.5 VDC MOTOR

John Oster B-9-2.7 amps. 5600 rpm. 1 3/4" Diam. x 3 3/4" Lg. Spine shaft. C. W. rotation. Will operate on 6 or 12 volts. New \$1.95

PE218, Leland. Input 28 V.D.C. at 90 amps. Output 115 V., 400 cycle at 1.5 K.V.A. \$24.95

EAGLE TIME DELAY RELAY, motor operated, 110V 60 cy., 20-min. New \$4.95



## DICTOGRAPH INTER-COMMUNICATION SETS

Designed to bring to homes and offices the conv. of two-way convers. w/o the use of telephone, household elec. current, or radio. Efficient to 800 ft. of flashlight batteries. New Pair \$9.95

BENDIX POWER SUPPLY, type MP-28BA. Uses dynamotor type DAIF. Input 25VDC, Output 540VDC, 450 MA. New \$29.95

## Standard Brand RHEOSTATS



High shock rheostats, four 13" plates, 100 ohms 8-2A, 175-345 V connected in series. Assembled for back of board mtg. or by reversing the supporting brackets for floor or table oper. New \$19.75

## NEW SYNCHROS

2J1G1 Control Transformer, 57.5/37.5 V., 400 cycle. \$1.50  
2J1F1 Selsyn Generator, 115 V., 400 cycle \$2.25  
5SDG Differential Generator 90/90 V., 400 cycle \$12.00  
1CT Control Transformer, 90/55 volts, 60 cycle \$35.00  
7G Generator, 115 V., 60 Cycle. New \$25.00

ELECTRONIC CONVERTER, model 1485. Input: 26 VDC. Output: 115V, 60 Cy, 1 ph. 50W. New \$14.95

## SELSYNS DIFFERENTIAL

115 V., 60 Cyc. #C78249

\$2.25 ea.

Used between two #C78248's as dampener. Can be converted to a 3600 RPM Motor in 10 minutes. Conversion sheet supplied.

BUD OSCILLATOR & BUFFER COIL, #OEL-160, 160 meter 50W. end linked. New \$95



## B. C. 604 F. M. TRANSMITTER

Wide or narrow band FM. 30 watt power output. Excellent possibility for ten or eleven meter exciter. Freq. 20-27.9 MC. Working space permits modification. W/ tubes but less power supply and xtl. LN \$11.50 Complete with Crystals \$25.00

# ELECTRO Sales Co.

399-405 ATLANTIC AVENUE

Dept. E-4

BOSTON 10, MASSACHUSETTS

LIBERTY 2-7890

ELECTRONICS — April, 1950



TAB THAT'S A BUY

TUBES Tested and Guaranteed

Table listing various vacuum tubes (e.g., 6A5, 6X4, 6Y5) with their respective prices and specifications.

AIRCRAFT INSTRUMENTS—USED, LIKE NEW TEMPERATURE Thermom Weston 606, Res. \$ 2.98

"Williamson" 15 Watts Hi-Fi Kit Internationally Famous. Simplicity of Design-Extraordinary linearity and lack of distortion.

Snooperoscope Infrared Image-Converter Tube Hi-Sensitivity simplified design 2" dia. Willemitte screen—Resolution up to 350 lines/in.

TRANSFORMER BUYS! 115 VAC Input G-E Teardrop Filament Xfmr Input 115230 V. 50/60 cys. Output: 5/2.5 V.

Write for Your FREE "TABOGRAM" "TAB" Spectralists in Industrial Electronic Equipment

THAT'S "TAB" THAT'S A BUY

"TAB" MONEY-BACK GUARANTEE 53 MIN. ORDER F.O.B. N.Y.C. ADD SHIPPING CHARGES AND 25% DEPOSIT. PHONE NO. 7-2730



# INDEX TO ADVERTISERS

Ace Engineering & Machine Co.	253	Electro-Voice, Inc.	168
Acheson Colloids Corp.	48	El-Tronics, Inc.	260
Adams & Westlake Co.	8	Erie Resistor Corp.	37
Advance Electric & Relay Co.	240	Fairchild Camera & Instrument Corp.	214
Aeronautical Communications Equip- ment, Inc.	40	Federal Telephone & Radio Corp.	137
Aerovox Corp.	42	Formica Insulation Co.	186
Alden Products Co.	198	Freel Transformer Co., Inc.	21
Allen Co., Inc., L. B.	260	Furst Electronics	238
Allen Mfg. Co.	180	Fusite Corporation	61
Allied Control Co., Inc.	36	Garrett Co., Inc., George K.	138
Altec Lansing Corp.	249	Gates Radio Co.	203
American Electrical Heater Co.	136	General Control Co.	253
American Phenolic Corp.	134	General Electric Co.	
American Screw Co.	6	Apparatus Dept.	18, 19
American Smelting & Refining Co.	159	Electronics Dept.	38, 49, 55, 169
American Television & Radio Co.	254	General Radio Co.	197
American Time Products, Inc.	46	Gramer Company, The	146
Amperex Electronic Corp.	3rd Cover	Graphite Metallizing Corp.	250
Amperite Co., Inc.	158	Grayhill	257
Ampex Electric Corp.	258	Green Instrument Co.	242
Amplifier Corp. of America	255	Gries Reproducer Corp.	260
Anaconda Wire & Cable Co.	201	Guardian Electric Mfg. Co.	185
Antara Products, General Aniline & Film Corp.	22, 23	Hardwick, Hindle, Inc.	27
Arkwright Finishing Co.	229	Hathaway Instrument Co.	222
Arma Corporation	135	Haydon Mfg. Co., Inc.	239
Armed Services Electro Standards Agency	255	Heath Company	162
Arnold Engineering Co.	187	Helland Research Corp.	238
Art Wire & Stamping Co.	292	Helmenann Electric Co.	123
Astatic Corp., The	140	Helipot Corp., The	175
Atomic Energy News Inc.	260	Hewlett-Packard Co.	57
Audak Company	292	Hexacon Electric Co.	247
Automatic Coil Winder & Electrical Equipment Co., Ltd.	220	Holliston Mills, Inc., The	234
Automatic Electric Sales Corp.	195	Howard Industries, Inc.	166
Ballantine Laboratories, Inc.	140	Hytron Radio & Electronics Corp.	15
Barker & Williamson, Inc.	144	Inductograph Products	255
Barrett Varnish Co.	260	Industrial Condenser Corp.	247
Barry Corporation	62	Instrument Resistors Co.	226
Bell Telephone Laboratories	199	International Rectifier Corp.	245
Bendix Aviation Corp.		International Resistance Co.	4, 5
Eclipse-Pioneer Division	226	Irvington Varnish & Insulator Co.	171
Pacific Division	236	I-T-E Circuit Breaker Co.	209
Bentley, Harris Mfg. Co.	155	Jelliff Mfg. Corp., C. O.	222
Berkeley Scientific Co.	255	Jensen Manufacturing Co.	29
Birtcher Corp., The	245	Johnson Co., E. F.	222, 257
Bishop Mfg. Corp.	255	Jones Div., Howard B. Cinch Mfg. Corp.	240
Blake & Johnson Co.	225	Jones Electronics Co., M. C.	166
Blaw-Knox Co.	163	Joy Manufacturing Co.	228
Boonton Radio Corp.	121	Kuhle Engineering Co.	172
Bridgeport Brass Co.	213	Kalbfell Laboratories, Inc.	251
Brook Electronics, Inc.	258	Karp Metal Products Co., Inc.	39
Brown Electro-Measurement Corp.	242	Kay Electric Co.	207
Brown Instruments Div., Minneapolis- Honeywell Regulator Co.	44	Kenyon Transformer Co., Inc.	136
Browning Laboratories, Inc.	156	Kester Solder Co.	117
Brush Development Co.	17	Kinney Manufacturing Co.	43
Buck Engineering Co., Inc.	260	Knight's Co., James	250
Bunnell & Co., J. H.	35	Kollsman Instrument Div., Square D Co.	54
Burnell & Co.	51	Kupfrian Manufacturing Co.	234
Cambridge Thermionic Corp.	254	Lambda Electronics Corp.	247
Cannon Electric Development Co.	233	Lampkin Laboratories, Inc.	260
Capitol Radio Engineering Institute	242	Langevin Manufacturing Corp.	249
Carborundum Co.	20	Legri S. Company, Inc.	158
Carter Motor Co.	252	Leukurt Electric Co.	228
Central Paper Co., Inc.	244	Linde Air Products Co., Unit of Carbide & Carbon Corp.	238
Central Scientific Co.	216	Liston-Folb, Div. Atlas Coil Winders, Inc.	230
Centralab, Div. Globe-Union, Inc.	11, 12, 13, 14	Littelfuse, Inc.	242
Cinch Manufacturing Corp.	113	Machlett Laboratories, Inc.	7
Clare & Co., C. P.	52, 53	Magnecord, Inc.	219
Clarostat Mfg. Co., Inc.	236	Mallory & Co., Inc., P. R.	64, 115
Cleveland Container Co.	173	Manning, Maxwell & Moore, Inc.	143
Clippard Instrument Laboratory, Inc.	247	Marion Electrical Instrument Co.	2
Cohn Corp., Sigmund	236	McGraw-Hill Book Co., Inc.	166, 252
Collins Radio Co.	161	Measurements Corp.	193
Communication Accessories Co.	235	Mica Insulator Co.	193
Condenser Products Co.	9	Millen Mfg. Co., Inc., James	244
Continental Carbon, Inc.	245	Milo Radio & Electronics Corp.	178
Continental-Diamond Fibre Co.	41	Mitchell-Rand Insulation Co., Inc.	10
Continental Electric Co.	170	Mosinee Paper Mills Co.	190
Cornell-Dubilier Electric Corp.	47	Muirhead & Co., Ltd.	3
Cornish Wire Co., Inc.	210	Mycalex Corp. of America	205
Cossor (Canada) Ltd.	228	National Company, Inc.	230
Coto-Coil Co., Inc.	218	National Research Corp.	32
Cramer Co., R. W.	232	National Vulcanized Fibre Co.	152
Cross Co., H.	260	New Hampshire Ball Bearings, Inc.	150
Dano Electric Co.	249	New Hermes, Inc.	258
Daven Co., The	237	North American Aviation, Inc.	142
Dial Light Co. of America	142	Nothelfer Winding Laboratories	248
Distillation Products Industries	200	Ohmite Manufacturing Co.	32A, 32B
Donnelly Elect. & Mfg. Co.	260	O'Neil-Irwin Mfg. Co.	256
Dow Corning Corp.	260	Paper Machinery & Research, Inc.	150
Driver-Harris Co.	165	Paramount Paper Tube Corp.	162
Du Mont Laboratories, Inc., Allen B.	33	Paris International Trade Fair	146
du Pont de Nemours & Co. (Inc.), E. I.	167	Park Metalware Co., Inc.	240
Eastern Air Devices, Inc.	251	Patton-MacGyver Co.	224
Eastman Kodak Co.		Philamon Laboratories	240
Cellulose Products Div.	141		
Industrial Photographic Div.	129		
Edo Corporation	181		
Eisler Engineering Co., Inc.	230, 260		
Eitel-McCullough, Inc.	35		
Electrical Reactance Corp.	153		
Electronic Instrument Co., Inc.	138		
Electrons, Inc.	182		

## The NEW —PRECISION— SERIES EV-20

**VTVM and Multi-Range Test Set**  
TRUE ZERO-CENTER on ALL VTVM ranges  
PLUS Direct Reading High Frequency Scales

### 48 RANGES TO

1200 Volts\*, 2000 Megohms, 12 amperes, + 63DB  
\*D.C.—VTVM ranges to 12,000 and 30,000 Volts when  
used with Series TV Super-High Voltage Test Probe.



### Range Specifications

- ★ SIX ALL-ZERO CENTER VTVM RANGES: — 13½ Megs. Constant Input Resistance. ± 3, ± 12, ± 30, ± 120, ± 300, ± 1200 volts. Direct Reading to ± 12 KV and ± 30 KV with Series TV Super-High Voltage Test Probe.
- ★ SIX SELF-CONTAINED OHMMETER-MEGOHMMETER RANGES: 0-2000-200,000 ohms. 0-2-20-200-2000 Megohms.
- ★ FOUR DIRECT READING HIGH FREQUENCY VTVM RANGES: 0-3-12-30-120 volts. (When used with RF-10A High Frequency Vacuum Tube Probe, Net Price \$14.00. No crystal rectifiers employed.)
- ★ SIX AC-DC AND OUTPUT VOLTAGE RANGES at 1000 ohms/volt. 0-3-12-30-120-300-1200 volts.
- ★ EIGHT D.C. CURRENT RANGES: 0-300 microamps. 0-1.2-3-12-30-120-1200 milliamps. 0-12 Amperes.
- ★ SIX DECIBEL RANGES from — 20 to + 63 DB. Calibrated for 600 ohm, 1 mw., zero DB reference level.

### Important Features

- ★ VOLTAGE REGULATED — BRIDGE CIRCUIT
- ★ DIRECT READING, ALL ZERO-CENTER VTVM eliminates frequent and inefficient shifting of test leads.
- ★ HIGH FREQ. VOLTAGE SCALES — DIRECT READING.
- ★ DUAL-BALANCED ELECTRONIC BRIDGE OHMMETER-MEGOHMMETER.
- ★ 4½" RECTANGULAR METER — 200 microamperes, ± 2%. Double-Sapphire, D'Arsonval construction.
- ★ 1% Film type, Metallized and Wire-Wound resistors.
- ★ Heavy gauge, loured steel case with plastic handle. Etched, anodized, aluminum panel.

### Net Selling Price \$6475

Complete with coaxial Circuit Isolating Test Probe, Shielded Ohmmeter Test Cable, Standard Test Leads, Ohmmeter battery. Case dimensions — 10½" x 6¼" x 5".

Also ask to see the "Precision" Series EV-10, DeLuxe VTVM—Megohmmeter with extra-large 7" meter, 59 Self-contained ranges to 6000 volts and 70 DB. on display at leading radio parts distributors.

Write for latest catalogue.



Export: 458 B'way, N. Y. C., U. S. A. Cables: MORHANEX  
In Canada: Atlas Radio Corp. Ltd., Toronto, Ontario

when you use  
the **Audax**  
**POLYPHASE...**



**ONE** single unit  
plays **ALL**  
your records  
**SUPERBLY...**  
and at less  
than the cost  
of ordinary  
magnetic pick-ups

Microgroove,  
78 r.p.m., etc.

This one single high grade pick-up yields such quality performance as you'd expect from two or more high grade magnetic units, each made expressly for a given type of recording.

Not only does Audax POLYPHASE accomplish just this - exciting admiration when you hear it, and performing vital functions in a way no other pick-up does - but it refutes the traditional idea that because Audax is so GOOD it costs more.

Not since the advent of the electric pick-up in 1926 has there been such astonished praise and acceptance of a new reproducer; musically and functionally.

Wide range performance with ANY type disc; sapphire or diamond, individually replaceable by you as easy as you changed needles. Low needle radiation. Ear quality *par excellence*.

**Radio Stations** - We have POLYPHASE models for you too, Lateral-Vertical included.

See it at your local dealer

Write for Editorial  
Reprint on  
**POLYPHASE Principles**  
to Dept. 2

**AUDAK COMPANY**

500 5th Ave., New York 18

Electro-Acoustical Units Since 1915

Photovolt Corp.	242
Plastics & Electronics Co.	260
Polarad Electronics Corp.	232
Potter & Brumfield	139
Potter Instrument Co., Inc.	170
Precision Apparatus Co., Inc.	291
Precision Paper Tube Co.	226
Presto Recording Corp.	26
Progressive Mfg. Co.	206
Pyramid Electric Co.	60
Pyramid Instrument Co.	189

Quaker City Gear Works	238
------------------------	-----

Radio Corp. of America	127, 192, 227, Back Cover
Radio Materials Corp.	56
Radio Receptor Co., Inc.	217
Railway Express Co., Air Express Div.	184
Rauland Corporation	24
Raytheon Manufacturing Co.	125
Reeves Hoffman Corp.	208
Remler Co., Ltd.	245
Robinson Aviation, Inc.	186
Ruby Chemical Co.	258

Sangamo Electric Co.	133
Scientific Electric, Div. of "S" Corrugated	154
Quenched Gap Co.	246
Scovill Mfg. Co.	224
Servo Corp. of America	246
Servomechanisms, Inc.	30, 31
Shallcross Manufacturing Co.	63
Sigma Instruments, Inc.	245
Society of the Plastics Industry, Inc., The	28
Sola Electric Co.	25
Sorensen & Co., Inc.	154
Specialty Battery Co.	162
Speer Carbon Co.	158
Sperry Products, Inc.	119
Sprague Electric Co.	34
Stackpole Carbon Co.	232
Standard Piezo Co.	249
Standard Pressed Steel Co.	241
Standard Telephones & Cables, Ltd.	251
Staver Co., Inc.	188
Stevens Mfg. Co., Inc.	251
Steward Manufacturing Co., D. M.	16, 150, 256
Stoddart Aircraft Radio Co.	176
Stupakoff Ceramic & Mfg. Co.	174
Superior Electric Co., The	179
Superior Tube Co.	151
Suprenant Mfg. Co.	131, 211
Sylvania Electric Products, Inc.	248

Tektronix, Inc.	145
Teledyne, Inc.	247
Television Equipment Corp.	260
Topflight Tape Co.	251
Torocell Co.	138
Transicoil Corp.	146
Transradio, Ltd.	223
Turner Company	238

Union Carbide & Carbon Corp., The Linde Air Products Co., Unit	238
United Transformer Co., Second Cover	106
University Loudspeakers, Inc.	164

Varian Associates	191
Veeder-Root, Inc.	194
Vickers Electric Div., Vickers, Inc.	204
Victoreen Instrument Co.	170
Vulcan Electric Co.	147

Waldes Kohlnoor, Inc.	148
Ward Leonard Electric Co.	234
Ward Products Corp.	231
Waterman Products Co., Inc.	243
Webster Electric Co.	215
Western Electronics Co.	183
Westinghouse Electric Corp.	58, 59, 157, 240
White Dental Mfg. Co., S. S.	249
Whitehead Stamping Co.	149
Whitney Metal Tool Co.	202
Wilcox Electric Co.	142
Workshop Associates, Inc., The	

Zophar Mills, Inc.	288
--------------------	-----

PROFESSIONAL SERVICES	259
-----------------------	-----

SEARCHLIGHT SECTION  
(Classified Advertising)

EMPLOYMENT	
Positions Vacant	261, 262
Selling Opportunities Offered	262
Positions Wanted	261
Selling Opportunities Wanted	261

SPECIAL SERVICES	
Contract Work	261

BUSINESS OPPORTUNITIES	
Offered	261

EQUIPMENT	
(Used or Surplus New)	
For Sale	263-290

WANTED	
Equipment	261, 286

ADVERTISERS INDEX

Acorn Electronics Corp.	288
Aircraft Radio Industries Co.	281
Arrow Sales, Inc.	274
Bell Aircraft Corp.	261
Bendix Aviation Corp.	261
Berry Box Co., Inc.	288
Blan	284
Columbia Electronics, Ltd.	283
Communications Devices Co.	282
Communications Equip. Co.	263, 264, 265
Cottone & Co., A.	282
Curtiss Wright Corp.	262
Dominik Surplus Co.	286
Dubin Electronics Co., Inc.	284
Electro Impulse Laboratory	281
Electro Sales Co.	289
Electronic Engineering Co., of Calif.	262
Electroncraft, Inc.	272
EPCO	288
Fair Radio Sales	285
Federated Purchaser Inc.	287
Finnegan, H.	286
Freed Radio Corp.	262
Horlick Co., William I.	279
Hughes Aircraft Co.	262
Instrument Associates	268, 269
International Standard Electric Corp.	286
Interstate Appliance Co.	283
Jefferis, T. K.	288
Kato Engineering Co.	287
Klein, Manuel	280
Kremetz & Co.	288
Lectronic Research Laboratories	275
Leru Laboratories, Inc.	287
Liberty Electronics, Inc.	282
Maritime Switchboard	278
Martin Co., The Glenn L.	261
Maspeth Telephone & Radio Corp.	285
Mogull Co., Inc., Alexander	286
Monmouth Radio Laboratories	284
Neomatic Inc.	287
Opad-Green Co.	283
Peak Electronics Co.	271
Poly Tech N. Y.	288
Precision Electrical Instrument Co.	283
Radio Corp. of America	261
Radio Ham Shack, Inc.	266, 267
Radio Shack Corp.	276
Reliance Merchandizing Co.	277
Servo-Tek Products Co., Inc.	273
Soundtronics Laboratories	285
Springfield Machinery Exchange	288
TAB	287, 290
Technical Index Service	261
Teletronics Laboratory Inc.	261
Titeflex, Inc.	286
United Surplus Materials	280
Universal General Corp.	284
Wells Sales Inc.	270
Weston Laboratories	287, 288

This Index is published as a convenience to the readers. Every care is taken to make it accurate but ELECTRONICS assumes no responsibility for errors or omissions.

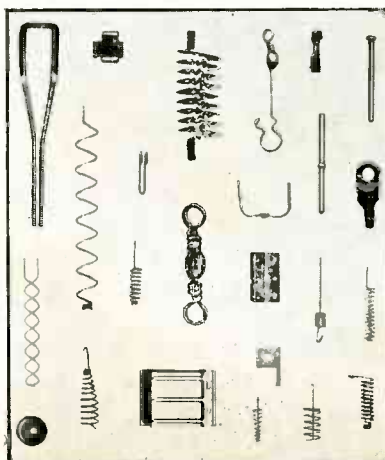

**SMALL PARTS**

Filaments, anodes, supports, springs, etc. for electronic tubes. Small wire and flat metal formed parts to your prints for your assemblies. Double pointed pins. Wire straightened and cut diameter up to 1/8-inch. Any length up to 12 feet.

LUXON fishing tackle accessories.

Inquiries will receive prompt attention.

**ART WIRE AND STAMPING CO.**

227 High St.

Newark 2, N. J.





# NEW and *preferred* AMPEREX tubes

for **COMMUNICATIONS** and  
**INDUSTRIAL Applications**

High Frequency • High Power • Proven Life

**Types**  
**492/5757 and 492-R/5758**  
(water cooled) (air cooled)

Filament — Thoriated Tungsten	
Voltage .....	5.0
Current (Amps.) .....	110
Amplification Factor .....	28
Maximum Ratings — Class "C" Telegraphy	
Plate Voltage .....	7500
Plate Current (Amps.) .....	2
Plate Dissipation (Kw.) .....	5
Typical Power Output (Kw.) .....	8.5
Frequency (Mc.) .....	100
Efficiency .....	75%
Inter-electrode Capacitances (mmf)	
Grid-Plate .....	21
Grid-Filament .....	30
Plate-Filament .....	0.6

Detailed characteristic sheets available on request



re-tube with  
**AMPEREX**

**AMPEREX ELECTRONIC CORP.**

25 WASHINGTON STREET, BROOKLYN 1, N. Y.

In Canada and Newfoundland: Rogers Majestic Limited  
11-19 Brentcliffe Road, Leaside, Toronto, Ontario, Canada

*preferred* FOR HIGH FREQUENCY OPERATION to 150 Mc.

*preferred* FOR GREATER EFFICIENCY

High Pervience • Thoriated Filaments •  
Low Filament Inductance • Specially Coated Grids •  
Low Grid Lead Inductance

*preferred* ESPECIALLY IN GROUNDED GRID CIRCUITS—  
Minimized Filament-Plate Capacitance

*preferred* FOR ECONOMY

Low Initial Cost • Low Operating Cost

**NEW!**

TYPE  
501-R/5759



Write for  
descriptive  
data sheets

TYPE  
502-R/5761



# 2 DECADES OF ELECTRONICS

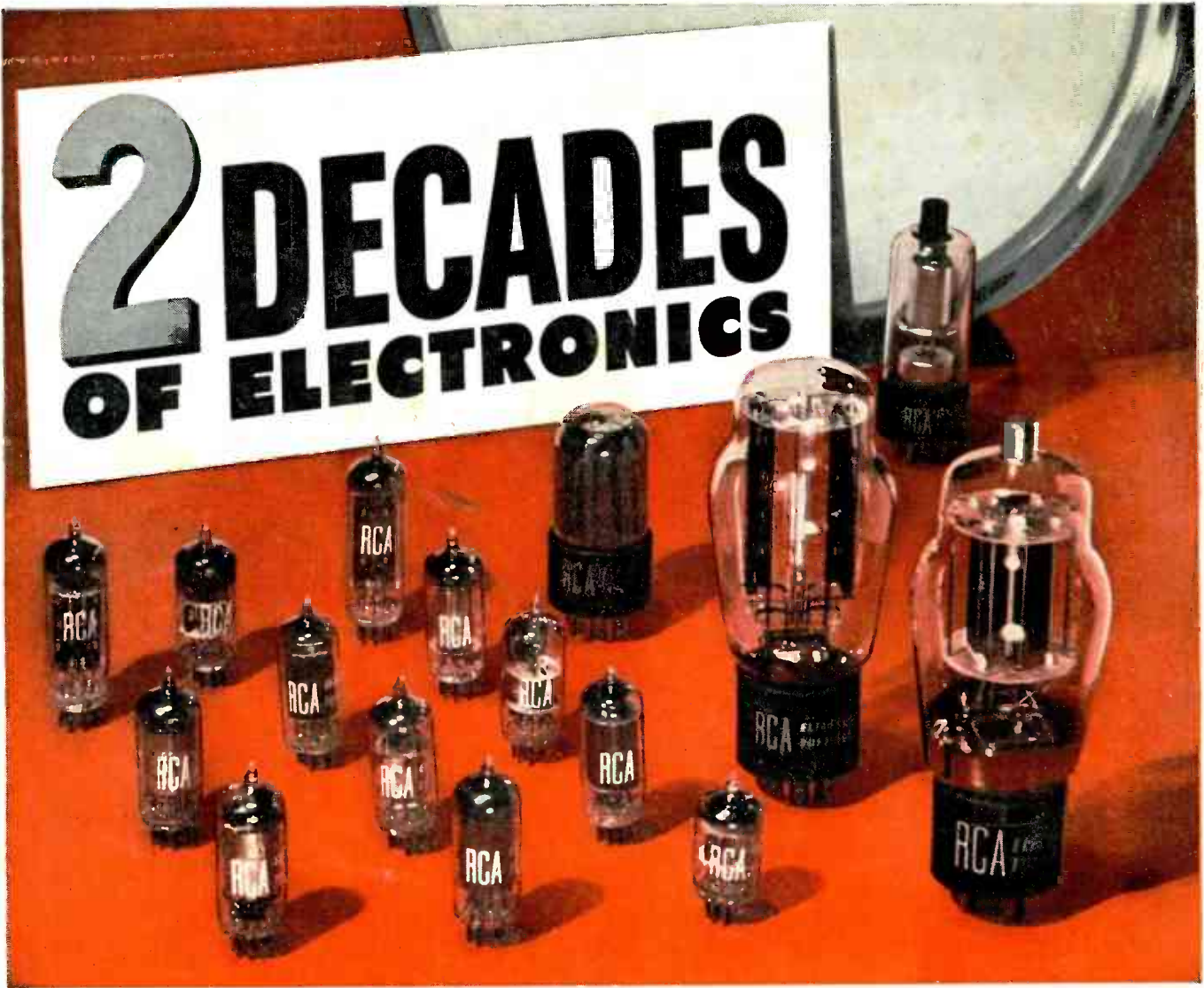

*Representative receiving tubes from  
the current RCA Preferred Types List*

## ... an industry acquires seven-league boots

Impressive as they are, the figures that chart the book value of the electronic industry over the past 20 years, are by no means the only measure of our industry's worth.

List the contributions of electronics to public safety and convenience. List the contributions of electronics to public entertainment. List the contributions to employment. List the opportunities which electronics has provided for hundreds of new businesses specializing in the design and manufacture of electronic equipment. And lastly—list the impact that electronics is making on business and industry in general.

Total them all and we have some measure of the stature of electronics today.

Throughout the past two decades RCA has been privileged to play a role of pioneering leadership—to make contributions, technically and commercially—which have advanced the progress and growth of electronics, both as an art and an industry.

In the vastly more promising future of electronics, RCA is pledged to continue its role of leadership—technically and commercially—with full and humble appreciation of the responsibility which leadership entails.



**RADIO CORPORATION of AMERICA**  
ELECTRON TUBES  
HARRISON, N. J.